

SYDNEY OLYMPIC PARK

Design Manual (DM)



Sydney
Olympic
Park

2025



Acknowledgment

Sydney Olympic Park Authority recognise First Nations Peoples' unique cultural and spiritual relationships to place and the rich contribution made to society.

First Nations Peoples take a holistic view of land, sky, water, and culture and see them as one, not in isolation from each other. The Sydney Olympic Park Place Vision and Strategy and Master Plan 2050 are based on the premise upheld by Aboriginal peoples that if we care for Country, it will care for us.

The lands and waterways of the Wangal extended along the southern side of the Burramattagal waters, the Parramatta River from Gadigal country, Darling Harbour to Baramada today known as Parramatta.

The river continues to have a deep relationship with the Gadigal, Wangal, Toongagal, Wallumdegal, Wategora and the Burramattagal people. All enjoyed the river as an important source of cultural activities, food gathering, spiritual practice and trade over thousands of years. The salt marshes were shelter for the water birds. At high tide crabs would be caught and fish easily speared. Ducks inhabited the creeks that fed into the river.

According to the Lore of the Iyura, the people of this place, it is said Biiami was responsible for shaping the land. He created the rivers, creeks, mountains, the bush, and forests. Biiami raised up his arms and sang everything into being. He looked about the land he had created and called it Bembul-ra. Then he created Iyura setting humans in his place of creation. Lores were put in place so people lived the right way for the continuation of life. Ceremonies and practices, song, dance, and rules of behaviour brought balance and protected a way of life.

This Elements Design Manual (DM) supersedes the Urban Design Manual 2009 (UEDM) and Parklands Elements Design Manual 2002 (PDM).

This Manual should be read in conjunction with the Sydney Olympic Park Master Plan 2050 and the Sydney Olympic Park Infrastructure Elements Design Manual 2018 (IECM).

Drawings and details included in this Document are a guide only and should not be used for construction. For construction design is to be prepared by proponents informed by this manual and including all required civil and structural design inputs to meet site specific requirements.

Published by Sydney Olympic Park Authority

sydneyolympicpark.nsw.gov.au

Design Manual

First published: November 2025

Sydney Olympic Park Authority reference number: D25/11259

More information

Prepared for Sydney Olympic Park Authority – Urban Renewal and Environment Team

Acknowledgments

Prepare by Environmental Partnership in collaboration with Sydney Olympic Park Authority

Copyright and disclaimer

© State of New South Wales through Department of Planning, Housing and Infrastructure 2025. Information contained in this publication is based on knowledge and understanding at the time of writing, October 2025, and is subject to change. For more information, please visit dpie.nsw.gov.au/copyright

Issue No.	Issued by	Date	Description
Rev 1	EP	14/10/2025	Final issue

Sydney Olympic Park is on the traditional lands of the Wann clan, known as the Wann-gal or Wangal.

Haslam's Creek Source : Paul K Robbins

Contents

		Page no.	Dwg no.
1.0	INTRODUCTION	10	
1.1	Place vision	12	
1.2	How to Use The Public Domain Deign Manual	16	
1.3	Companion Documents	18	
1.4	Public Domain Design Considerations	19	
	1.4.1 Considerations for Major Events	19	
	1.4.2 Access considerations	19	
	1.4.3 Public Domain Procurement Considerations	19	
1.5	General Principles for Design Elements Selection	20	
1.6	Sydney Olympic Park Precinct Embodied Carbon Guidelines	21	
1.7	Public Domain Design Approvals	22	
	1.7.1 Public domain plans	22	
	1.7.2 Urban Space and Parklands Plans	22	
	1.7.3 Checklist for Public Domain Approvals	23	
2.0	PLACEMENT AND COORDINATION	24	
2.0	Introduction	26	
2.1	Street Layout & Elements Placement Parameters	26	
2.2	Street Hierarchy and Types	26	
2.3	Street Structure	28	
2.4	Footway Arrangement	30	
	2.4.1 Fully Paved Footway Elements Placement Principles	30	
	2.4.2 Footpath with Landscape Verge Elements Placement Principles	32	
	2.4.3 Footpath within Park/Parkland Elements Placement Principles	33	
2.5	Intersection Arrangement	34	
2.6	Pedestrian (Zebra) Crossing Arrangement	36	
2.7	Continuous Footpath Arrangement	38	
2.8	Driveway Arrangement	40	
3.0	ELEMENTS AND DETAILS	42	
3.0	Elements and Details	44	
3.1	Pavements and Levels Changes	46	
	3.1.1 Objectives	48	
	3.1.2 Paving	48	
	3.1.3 Procurement	48	
	3.1.4 Footway Accessibility	48	
	3.1.5 Paving Strategy	50	
	3.1.6 Pavements and Levels Changes Guidelines	52	
	Paving Interface at Intersection	52	PL01
	Paving Direction Change	53	PL02

		Page no.	Dwg no.
3.0	ELEMENTS AND DETAILS (CONT.)		
3.1	Pavement and Levels Changes (Cont.)		
	Typical Large Format Pedestrian Paving	54	PL03
	Typical Precast Pavers - Non Interlocking	56	PL04
	Typical Precast Pavers - Interlocking	58	PL05
	Typical Vehicle Crossover	60	PL06
	Typical Granite Pavement	62	PL07
	Typical Permeable Pavement	64	PL08
	Typical Concrete Pavement	66	PL09
	Typical Asphaltic Concrete Pavement	68	PL10
	Typical Kerb Ramp - Small	70	PL11
	Typical Kerb Ramp - Large	72	PL12
	Typical Paved Steps	74	PL13
	Typical Concrete Steps	76	PL14
	Typical Ramp	78	PL15
	Hazard Warning Tactile Ground Surface Indicators	80	PL16
	Directional Tactile Ground Surface Indicators	82	PL17
	Typical Infill Pit Lid - Single Part	84	PL18
	Typical Infill Pit Lid - Multi Part	86	PL19
	Typical Trench Grate	88	PL20
	200mm Wide Insitu Concrete Retaining Wall	90	PL21
	400mm Wide Insitu Concrete Wall	92	PL22
	Typical Gabion Wall	94	PL23
	Steel Edge	96	PL24
3.2	Furniture	98	
	3.2.1 Objectives	100	
	3.2.2 Relevant Standards	100	
	3.2.3 Procurement	100	
	3.2.4 Furniture Guidelines	102	
	Backed Seat	102	F01
	Bench Seat	104	F02
	Waterfront Bench Seat	106	F03
	Picnic Table Set	108	F04
	Drinking Fountain - Urban Area	110	F05
	Drinking Fountain - Parklands	112	F06
	Bin Enclosure	114	F07
	Hot Coal Bin	116	F08
	Bollard (General) - Urban Area	118	F09
	Bollard (Truckstopper) - Urban Area	120	F10

Contents (Cont.)

		Page no.	Dwg no.
3.0	ELEMENTS AND DETAILS (CONT.)		
3.2	Furniture (Cont.)		
	Bollard (General) - Parklands	122	F11
	Bollard (Shared Path/ Bike path) - parklands	124	F12
	Bike Racks	126	F13
	Barbecue	128	F14
	Tree Grate	130	F15
	Movable Chair	132	F16
	Movable Picnic Table Set	134	F17
	Fixed Above-ground Planter	136	F18
	Palisade Fence Type 1A - 1.1m High	138	F19
	Palisade Fence Type 1B - 1.9m High	140	F20
	Palisade Fence Type 2 - 1.8m High	142	F21
	Palisade Fence Type 2 - Vehicle Gate	144	F22
	Permanent Frog Fence	146	F23
	Vehicle Barrier	150	F24
	Handrail - Wall Mounted	152	F25
	Handrail - Freestanding	154	F26
3.3	Shelter Structure	156	
3.3.1	Design Approach	158	
3.3.2	Role within Parklands	158	
3.3.3	Materials	158	
3.3.4	Siting	158	
3.3.5	Relevant Standards	158	
3.3.6	Procurement	158	
3.3.7	Shelter Structure Guidelines	160	
	Picnic Shelter	160	SO1
	Tension Membrane Shade Structure	164	SO2
	Bus Shelter	166	SO3
3.4	Lighting	168	
3.4.4	Lighting Guidelines	170	
	Existing Lighting Poles	170	
	12m High Multi-function Pole	172	L01
	9m High Multi-function Pole	173	L02
	6m High Pedestrian Light Pole	174	L03
	3.5m or 4m High Pedestrian Light Pole	175	L04
	Standard Pole - Type 1	176	L05
	Standard Pole - Type 2	178	L06
	Standard Pole - Type 3	180	L07

		Page no.	dwg no.
3.0	ELEMENTS AND DETAILS (CONT.)		
3.4	Lighting (Cont.)		
	Parklands Solar Light - Option 1	182	L08
	Parklands Solar Light - Option 2	184	L09
3.5	Engineering Elements	186	
3.5.1	Objectives	188	
3.5.2	Relevant Standards	188	
3.5.3	Procurement	188	
3.5.4	Engineering Elements Guidelines	190	
	Typical Precast Raised Kerb	190	EG01
	Typical Precast Flush Kerb	192	EG02
	Typical Insitu Flush Kerb	194	EG03
	Typical Insitu Kerb & Gutter - Standard Size	196	EG04
	Typical Insitu Kerb & Gutter - Large Size	198	EG05
	Typical Permeable Kerb	200	EG06
	Typical V-drain Swale	202	EG07
	Typical Vehicle Kerb Layback	204	EG08
3.6	Planting	206	
3.6.1	Objectives	208	
3.6.2	Relevant Standards	208	
3.6.3	Procurement	208	
3.6.4	Planting Species Selection	208	
3.6.5	Tree Placement and Spacing	209	
3.6.6	Soil Volume	209	
3.6.7	Planting Guidelines	210	
	Tree Planting in Verge (less than 1.5m wide)	210	PT01
	Tree Planting in Verge (greater than 1.5m wide)	212	PT02
	Tree Planting with Tree Grate in Paved Footpath	214	PT03
	Tree Planting with Garden Bed in Paved Footpath	216	PT04
	Tree Planting with Soil Vault System in Paved Footpath	218	PT05
	Tree Planting in Carriageway - Passive Irrigation	220	PT06
	Tree Planting in Carriageway - Bioretention Tree Pit	222	PT07
	Tree Planting in Park	224	PT08
	Garden Bed and Mass Planting Bed	226	PT09
	Revegetation	228	PT10
	Turf	230	PT11
	Swale	232	PT12





Sydney Olympic Park Design Manual

INTRODUCTION

1.0

Sydney Olympic Park Authority (Sydney Olympic Park Authority) is committed to delivering a public domain of consistent high quality that embraces sustainability and a healthy

environment for residents and visitors.

Good initial design of built assets and material selection are instrumental in managing quality, aesthetics, maintenance and replacement requirements across Sydney Olympic Park.

The particular needs of Sydney Olympic Park as a major event and recreation precinct have been a key factor in the selection of public domain elements found in this document.

The Design Manual (DM), along with the Sydney Olympic Park Master Plan 2050 (Master Plan 2050) will ensure on-going high quality and sustainable public domain design for the urban core and parklands of Sydney Olympic Park.

1.1 Place vision

The Sydney Olympic Park 2050 Draft Place Vision & Strategy envisions that in 2050, Sydney Olympic Park will be a highly-connected series of diverse neighbourhoods and experiences – from the big buzz and roar of the crowd to the small moments of peaceful solitude – and where curious minds experiment to solve challenges now and for the future.

Many will live and work in this multi-faceted suburb, others will visit – for events, for its diverse attractions or for everyday retail and neighbourhood needs.

Sydney Olympic Park’s diverse communities will each experience the Park differently. It’s what makes it a complex and thriving place.

The Vision is the outcome of stakeholder engagement and reflects the collective ambitions for the evolution of Sydney Olympic Park.

The Vision comprises the vision statement, three place pillars and ten strategic directions as below.

The aspirations for Sydney Olympic Park in 2050 is presented in four parts: the Vision, Place Pillars, Strategic Directions and Key Moves.

The Vision

The vision outlines what Sydney Olympic Park would like to be known as by 2050. It draws together the aspirations outlined within the Place Pillars and Strategic Directions.

SYDNEY OLYMPIC PARK IS SYDNEY'S BEATING GREEN HEART

Place Pillars

The place pillars reflect the DNA of Sydney Olympic Park and the foundations from which everything is built upon. The pillars act as values - the lens through which all decision-making will be made as Sydney Olympic Park progresses toward its vision.

Wangal

Respect and care for Country

Dynamic

A place that adapts to changing needs

Thriving

A regenerative exemplar

Strategic Directions

These ten Strategic Directions will shape the future of Sydney Olympic Park. These highlight a series of opportunities that leverage Sydney Olympic Park’s natural and built features, its engaged community and unique governance structure.

These Strategic Directions are supported by a series of actions that provide a framework for bringing the vision to life.

<p>1</p>  <p>A place to call home</p>	<p>2</p>  <p>A liveable and complete community</p>	<p>3</p>  <p>Connected, pedestrianised and intuitive</p>	<p>4</p>  <p>Immersive, rich and unique experiences</p>	<p>5</p>  <p>A thriving public domain day and night</p>
<p>6</p>  <p>A living laboratory for urban innovation</p>	<p>7</p>  <p>An economically productive and distinctive place</p>	<p>8</p>  <p>Carbon positive and circular</p>	<p>9</p>  <p>The green lungs of Sydney</p>	<p>10</p>  <p>A delivery model fit for the future</p>

Source: Sydney Olympic Park 2050 Draft Place Vision & Strategy, Wangal Country

Figure 1.1 Site Plan

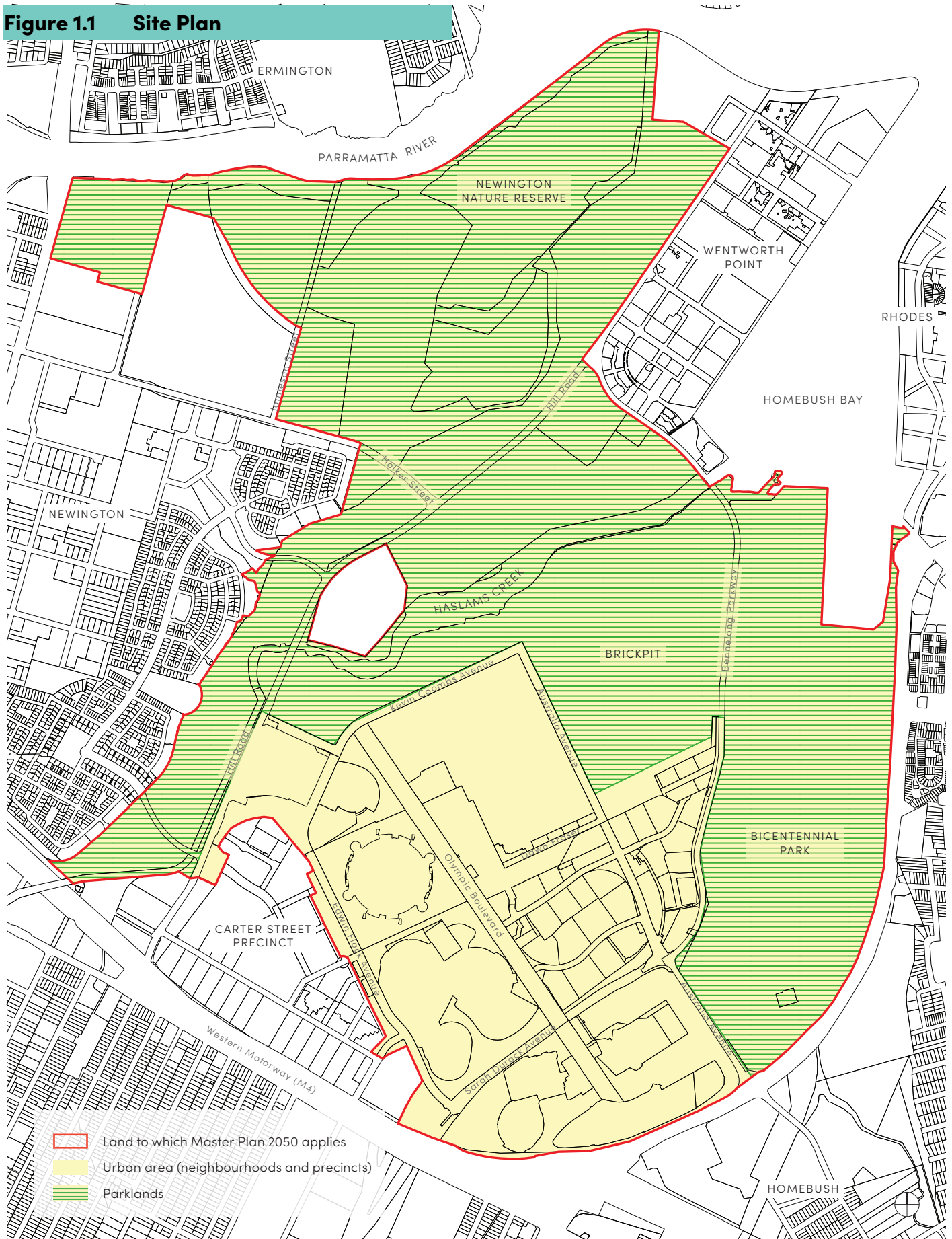

Source: Sydney Olympic Park Master Plan 2050

2050 Landscape and Public Domain Vision

The themes, principles and objectives of the Masterplan 2050 must be demonstrated in all planning, design and construction projects for delivery of the public domain and open spaces of Sydney Olympic Park.

SOURCE: Sydney Olympic Park Master Plan 2050 - Connecting with Country Technical Report 2024, Yerrabingin

Place Pillar	Wangal	
Connection with Country theme	Cultural connections	
Key move	Identity	An Evolving Perspective
Strategic direction	A place to call home	A livable and complete community

Landscape and Public Domain objectives

- Achieve an affordable and accessible mix of housing to meet needs of a diverse community
- For Sydney Olympic Park to become a strategic Centre with a number of thriving neighbourhoods
- To provide sufficient open space for the growing Sydney Olympic Park community and adjacent neighbourhoods
- Provide flexible public domain that caters for the needs of a growing community
- A suburb that future generations are proud to call home
- Activate the public domain with spaces for informal participation and create the conditions for local community use
- Provide a diverse range of smaller spaces and events that cater to locals
- Deliver new social infrastructure for creative and cultural production and participation



- Deliver a highly connected and car light suburb that prioritises pedestrian movement and leverages public transport connections
- Connect Sydney Olympic Park to adjacent neighbourhoods through a range of transport modes
- Implement and complete active and public transport networks that work in harmony
- Provide strong connection to regional NSW
- Explore innovative approaches to personal mobility across Sydney Olympic Park
- Offer a range of experiences (passive and active) for people to connect to the parklands

- Sydney Olympic Park will be a major cultural, entertainment, sporting and tourism destination, where events and attractions big and small breathe life into it the every day
- Diversify Sydney Olympic Park's identity as a visitor destination
- Build on Sydney Olympic Park's role as the home of sport and enhance it's Olympic legacy
- Better celebrate the unique offerings of Sydney Olympic Park by providing improved visitor experience and amenity

- Sydney Olympic Park will become a cool, green and nature positive place, that responds to Wangal Country
- Plan for climate change driven ecosystem migration and change
- For the parklands to continue ecological and cultural regeneration, with thriving environments and ecological refuges
- Provide opportunities for positive interactions with nature
- Improve urban greening within the Urban centre

- For Sydney Olympic Park's public domain to become diverse place with unique experiences day and night
- Provide human-scaled spaces and pedestrians links where people feel safe and welcome
- Provide spaces that cater for locals, visitors and the coming together of both
- Design and manage the public domain to increase informal sport and recreational opportunities

1.2 How to Use the DM

What are the Objectives of the DM ?

The purpose of the DM is to deliver an integrated and consistently high quality public realm for Sydney Olympic Park through both the urban core of the Urban Centre and the precinct's various parks and open spaces.

The DM as a technical manual sets standards of performance and design quality which considers robustness, fitness for purpose, sustainability of material selection, operational efficiency and integration with the existing public domain. The DM also sets standards for public safety, amenity and universal access.

The DM seeks to guide materials, placement and coordination of elements to:

- Reinforce street and open space hierarchy and special character
- Nominate required paths of travel for pedestrians, cyclists, wheelchairs, prams and the integration with uses such as outdoor eating
- Achieve a seamless integration of elements into the paved ground plane and open spaces
- Select, site and implement street and park furniture
- Guide incorporation of plantings to streets and open spaces

The Sydney Olympic Park Signage Manual is a separate companion document that addresses requirements for design and implementation of wayfinding and interpretive signage in public spaces.

Who Should Use this Document

The DM as a technical reference manual is for use by decision makers both within the Authority and those involved in making informed planning and design decisions for all new developments at Sydney Olympic Park.

The DM is relevant to the following groups:

- Sydney Olympic Park Authority decision makers

- External decision makers involved with commercial developments throughout various stages of planning, design and construction:
 - Requests for Development Proposal (RFDP)
 - Agreements for Lease (AFL)
 - Development Applications (DA)
 - Construction Certificates (CC)
 - Delivery and Construction
- Planners, Urban Designers, Architects, Landscape Architects, Graphic Designers, Lighting and Civil Engineers and all professionals who contribute to the design of the public domain
- Building and public domain construction contractors

How Should the DM be Used

The DM should be read in conjunction with the following planning frameworks and relevant Sydney Olympic Park Authority design guidelines:

- Master Plan 2050 and annexures
- Access Guidelines
- Public Domain Lighting Guidelines
- Environmental Guidelines
- Signage Guidelines
- Outdoor Dining Policy
- Protection of Trees on Construction Sites Guidelines
- Other references:
 - Commercial Signage Policy
 - Major Event Security Risk Management Policy
 - Stormwater Management and Water Sensitive Urban Design Policy

Companion document relationships are illustrated at Figure 1.1, page 18.

Drawings and details included in this Document are a guide only and should not be used for construction.

For Construction design is to be prepared by proponents informed by this manual and including all required civil and structural design inputs to meet site specific requirements.

Step by Step Guide for Using the DM

Refer

<p>Step 1 Identify where your site is within Sydney Olympic Park Authority lands and the</p>	<p>Identify the location of the (re)development site and establish the street type - refer Figure 2.2.1.</p> <p>Streets (existing and proposed) in each neighbourhood are colour coded relative to their street hierarchy. Open Space design is to be guided by Master Plan 2050. Consider typical cross-sections for the street type provided in Master Plan 2050 to understand the anticipated character of the streetscape.</p>	<p>Section 2.0 / Master Plan 2050</p>
<p>Step 2 Site Analysis</p>	<p>Prepare a site analysis of the selected site. An analysis of the site and street environment must consider:</p> <ul style="list-style-type: none"> • micro-climate (overshadowing, solar access, winds etc) • existing trees • views • utilities • ground levels • integration with adjoining public domain areas and buildings. <p>The analysis is to be represented in a drawing and design report as part of the package submitted for approval to the Authority and/or NSW Planning Portal.</p>	<p>N/A</p>
<p>Step 3 Site specific design plan</p>	<p>A site specific design plan is to be prepared by a registered landscape architect. The plan is to be accurate and appropriately scaled to describe the layout, spacial qualities, movement allowance and planting layout. Incorporate material selection in accordance with the Design Manual.</p> <p>Materials nominated in site specific designs that have not been included in this Design Manual will be assessed by the Principal Public Domain Designer through the design review process.</p>	<p>Section 2.0/3.0</p>
<p>Step 4 Confirm and arrange elements</p>	<p>The 'Placement and coordination' section of this Design Manual provides details of the critical setout and interrelationships of key elements within the public domain including footpath widths, furniture placement, intersections and crossings.</p> <p>The proposed design is to follow the nominated placement of elements. Exceptions may be considered with rationalisation for the exception.</p>	<p>Section 2.0/3.0</p>
<p>Step 5 Liaison with the Authority and submission of public domain design</p>	<p>Appropriately scaled plans and sections are to be prepared for negotiations and approval by the Authority.</p> <p>The public domain packages are to be fully coordinated with engineering and architectural drawings. Refer to checklist at the end of this section.</p>	<p>Section 1.0</p>

1.3 Companion Documents

MASTER PLAN



Sydney Olympic Park Master Plan 2050



Sydney Olympic Park Master Plan 2050 - Annexure D Landscape and Public Domain Report

MANUALS

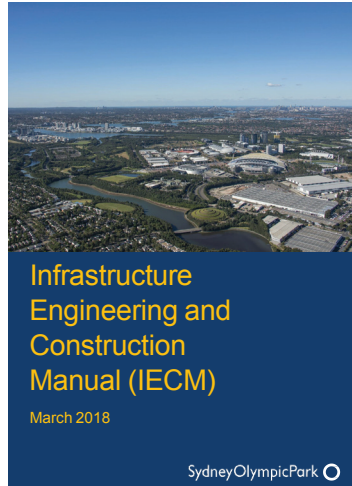

Sydney Olympic Park Infrastructure Engineering and Construction Manual MAR 2018 (IECM)

POLICY / CODE / GUIDELINES

ACCESS GUIDELINES
(5TH EDITION -2017)

OUTDOOR DINING POLICY
(2025)

URBAN GREENING POLICY
(2024)

ENVIRONMENTAL GUIDELINES
(2025)

PARKLANDS PLAN OF
MANAGEMENT
(2010)

STORMWATER
MANAGEMENT AND WATER
SENSITIVE URBAN DESIGN
(2024)

PUBLIC DOMAIN LIGHTING
GUIDELINES
(2025)

1.4 Public Domain Design Considerations

1.4.1 Considerations for Major Events

Since its inception, the Sydney Olympic Park public domain has been purpose designed for large events that will continue to be hosted at the park on a frequent basis. The following strategies enable large events to be hosted successfully in the park.

- Squares, parks and footpaths near the main stadiums are generously sized.
- Kerbs are flush to facilitate equal access in the busiest parts of the public domain.
- Kerb ramps are generously scaled.
- Light poles in event areas have the potential for brackets for banners and attachment and connection of communications equipment.
- Light standards in event areas incorporate provisions for low voltage power, communications and 3 phase power.
- Directional signs in event areas are detachable to allow for changes of venue name/purpose in event mode.
- Placement guidelines consider major crowd movements and clear paths of travel for access.
- The Plaza light tower, with their easily-modified dynamic signage and capacity to accommodate permanent and temporary facilities, have been developed specifically for major events.

1.4.2 Access Considerations

The strong drive to provide equal access established during the Olympics has been continued through design works at Sydney Olympic Park as a fundamental design requirement. Specific access requirements are detailed in the Access Guidelines edition 5 2017.

This approach been developed and refined in close collaboration with access consultants, to meet or better AS1428.4 for paving, lighting, street furniture and signage, with many elements, including tree grates, paving and bollards, being specifically designed or modified to meet access requirements. The key recommendation of the Access Guidelines is to provide consistent linkages to, within and between all Sydney Olympic Park venues and facilities.

The implementation of the recommendations of the DM will ensure a consistent approach to access in the public domain.

1.4.3 Public Domain Procurement Considerations

The procurement of items within the public domain is the overall responsibility of the Sydney Olympic Park Authority, and has been subject to the probity requirements of Government tendering and supply. Manufacturers are listed where known. Shop drawings and detailed component lists are available from the Authority on request.

Procurement of urban elements must comply with the NSW Government procurement policies. Material selection is to be in accordance with the objectives section of the Authority's 'Environmental Guidelines'.

1.5 General Principles for Elements Selection

Public domain design elements across the public domain of Sydney Olympic Park are to be

- **high quality,**
- **consistent,**
- **people centric and coordinated.**

The public domain design elements selected for each project are to be:

- **Functional, robust, elegantly detailed and easily maintained,**
- **Universally accessible,**
- **In accordance with the requirements of Sydney Olympic Park Authority's Environmental Guidelines,**
- **Sustainably designed in every aspect, including but not limited to:**
 - **Reusing existing materials, where possible**
 - **Minimising embodied carbon**
 - **Recyclable at the end of life.**

PLACEMENT

Placement of furniture elements must consider the function of the space relative to everyday use and major event mode within the urban centre.

Placement of public domain elements within the parklands must take into consideration the placement relative to waterways, potential flooding and natural habitats.

PLANTING

Planting provisions are to follow the requirements of Sydney Olympic Park Authority's Urban Greening Policy and Urban Greening Procedure.

STANDARDS COMPLIANCE

All design and implementation work must comply with Australian Standards and National Building Code of Australia.

PROCUREMENT

Public domain design elements that are required for works delivered by the Authority will be procured in accordance with probity requirements of NSW Government tendering and supply procurement policies.

Public domain design elements that are required for works delivered by developers or other entities will be procured by the developer or other entity for their project in accordance with this Design Manual.

The products nominated in this Design Manual indicate the quality and style required for projects within Sydney Olympic Park. Products equal to those indicated may be used within approval from the Authority.

1.6 Precinct Embodied Carbon Guidelines

This guideline defines how embodied (upfront) carbon emissions must be assessed and reduced across all new public infrastructure delivered in the Sydney Olympic Park precinct.

It sets out clear expectations for design teams, contractors, and developers regarding measurement methodologies, reduction targets, procurement protocols, and offset requirements.

By embedding these performance standards into all future developments—whether public or private, buildings or infrastructure—the Authority is reinforcing its commitment to climate-aligned growth, supporting the delivery of carbon-positive outcomes, and positioning the precinct as a national leader in low-carbon urban regeneration.

The Authority is committed to climate-aligned growth, supporting the delivery of carbon-positive outcomes, and positioning the precinct as a national leader in low-carbon urban regeneration.

This applies to the selection of materials in the public domain, among other climate risk mitigating initiatives.

Precinct Wide Requirements (All Projects)

These elements apply to infrastructure:

Demolition Offsets:

- Where existing structures less than 50 years old are removed, projects must offset associated embodied emissions unless proven reuse is feasible.
- For any structure less than 30 years old, 100% of the embodied carbon must be offset.
- For structures aged between 30–50 years, a scaled offset applies with a 5% reduction in obligation per year over 30.
- Structures older than 50 years are exempt from offset requirements.

Carbon Disclosure:

- Upfront Carbon Assessment documentation must clearly identify assumptions, scope, materials used, and all offset methodologies.

Requirements for Public Infrastructure

Requirement Area	Guideline Expectation
Assessment	All projects are to undertake an upfront carbon LCA using an EN 15978-compliant tool (e.g. eTool, OneClick).
Reduction Target	Demonstrate a 20% reduction in embodied carbon compared to a reference design.
Design Approach	Incorporate design-for-low-carbon strategies such as: <ul style="list-style-type: none"> – Recycled aggregates, geopolymers concrete, low-carbon steel – Modular or prefabricated structural systems – Reduced overspecification and efficient layout
Procurement	Require EPDs for major materials; embed carbon performance criteria in tendering; and include low-carbon alternatives in value engineering.
Offsetting	If infrastructure or landscape demolition involves structures <50 years old, the associated carbon must be offset unless reuse is demonstrated.
Documentation	Submit a Preliminary Carbon Report at 30% design and a Final Carbon Summary post-construction. Projects may be reviewed by the Authority’s sustainability advisor.

1.7 Public Domain Design Approvals

This document is for design guidance purposes. Detailed design by qualified and experienced landscape architecture, engineering and related consultants is required for construction projects.

All work is to comply with relevant Australian Standards and Building Code of Australia requirements. If discrepancies occur between given dimensions and AS and BCA requirements you are required to seek advice from the Authority before proceeding.

1.7.1 Public Domain Plans

Public domain plans including cross sections and long sections and specifications are to be prepared and submitted for approval for all new buildings, streets or parts of streets and must meet the following requirements. The plans are to be drawn at minimum scale 1:200. and are to show:

- all existing trees and other urban elements;
- the main building line showing pedestrian and vehicular entrances;
- awnings and colonnades;
- kerbs, kerb ramps and vehicle cross overs;
- pavement types and detail;
- kerb, stairs, handrails, ramps and balustrades;
- street furniture including signs and parking meters;
- services, pit lids and drainage;
- lights;
- trees, tree pits and garden beds including irrigation and subsoil drainage;
- plant species, sizes and location;
- public art; and
- levels at the entrances, building line, top of kerb and bottom of kerb.

The longitudinal sections are to be at minimum scale 1:100.

Cross sections are to be drawn at minimum 10m intervals at minimum scale 1:50 (with 1:10 exaggerated vertical scale), including pavements and sub base and proposed cross falls.

1.7.2 Urban Space and Parklands Plans

Plans for all new parks and urban squares are to be prepared for approval.

Design opportunities, principles and performance benchmarks are provided for all public domain parks and squares in the Masterplan 2050.

The DM specifies elements for use in public and private parks and urban squares. Private and semi-private spaces within development sites are to be designed and detailed to reflect and reinforce the strategies and elements described in the DM.



Source: James Horan Photography

1.7.3 Checklist for Public Domain Approvals

This checklist is a guide to the level of information required at each stage of development within the urban area and parklands.

While the DM is provided as a technical reference document to clearly set out design intent and performance standards for the public domain, liaison with the Authority prior to lodgement is recommended to resolve many site specific issues and expedite development consent.

It is recommended that a Registered Landscape Architect prepare these applications.

STEP 1	PRELIMINARY
	<p>Liaison with appropriate Authority staff during preliminary stages will assist you to identify :</p> <ul style="list-style-type: none"> critical operational requirements; interface issues with existing public domain areas, and confirm relevant development guidelines and standards.
STEP 2	DEVELOPMENT ASSESSMENT
	<ul style="list-style-type: none"> Prepare coordinated Public Domain plans @ 1:200 scale with all material finishes, siting of street furniture, public lighting, access elements and any proposed commercial outdoor seating zones. Prepare proposed external levels plan indicating survey of existing kerb, road and ramp levels and proposed finished ground floor levels. Prepare planting plan with existing trees proposed to be retained and/or removed, new trees and planting with a complete schedule of species, planting details, planting densities and container sizes. Obtain Land Owners Consent if required. Assessment by Department of Planning or delegation to the Authority for Determination.
STEP 3	IMPLEMENTATION
	<p>Prior to commencement of works, the following information is required to be lodged with the Authority for coordination and review:</p> <ul style="list-style-type: none"> setout information coordinated with existing infrastructure and services; landscape/ streetscape plans including: <ul style="list-style-type: none"> Pavement types Retaining wall Street furniture Street Lighting design including pits locations, poles and light level analysis and a table showing the complaint (min, max, uniformity) for normal, energy saving and event mode Drainage including WSUD Utilities / Pits Survey marks Electrical / comms pillars construction details for all hard and soft landscape elements, and technical notes and performance specifications.
STEP 4	PRACTICAL COMPLETION
	<ul style="list-style-type: none"> Prepare and submit as-built public domain plans to reflect amendments required during construction phase.

Sydney Olympic Park Design Manual

**PLACEMENT AND
COORDINATION**

2.0

Effective siting and positioning of urban elements as a co-ordinated composition is essential to streetscapes and public domain spaces.

Well composed public domain elements contribute to spaces being both functional and intuitive as well as aesthetically pleasing.

Well placed and coordinated elements:

- reinforce street hierarchy and character;
- maintain required paths of movement for pedestrians;
- are more likely to be used
- provide a logical and clear composition;
- are integrated seamlessly into the paved ground plane;
- complement the arrangement of other street elements; and
- are located as part of a consistent legible approach across the precinct.

This section offers key guidance on the spatial arrangement and coordination of public infrastructure elements within both street and park environments. The guidance supports the creation of public spaces that are functional, attractive, accessible, inclusive, safe, comfortable, and sustainable.

2.1 Street Layout & Element Placement Parameters

The following standards apply to all street public domain design works within Sydney Olympic Park:

- AS 1428.1-2021 Australian Standard Design for Access and Mobility Part 1: General requirements for access – new building work
- AS 1428.2-1992 Australian Standard Design for Access and Mobility Part 2: Enhanced and additional requirements – Buildings and facilities
- AS/NZS 1428.4.1:2009 and AS/NZS 1428.4.2: 2022 Australian/New Zealand Standard Design for Access and Mobility Part 4: Tactile indicators
- Austroads Guide to Road Design Part 6A Paths for Walking and Cycling
- Austroads Guide to Road Design Part 4 Intersections and Crossings: General
- Cycling Aspects of Austroads Guides
- NSW Bicycle Guidelines
- Sydney Olympic Park Access Guidelines 2017
- Sydney Olympic Park Outdoor Dining Policy 2025
- Sydney Olympic Park Environmental Guidelines 2025
- Sydney Olympic Park Urban Greening Policy 2024
- Infrastructure Engineering and Construction Manual 2018
- Sydney Olympic Park Master Plan 2050
- NSW Movement and Place Framework
- Transport for NSW Road User Space Allocation Policy

2.2 Street Hierarchy and Types

The Sydney Olympic Park Master Plan 2050 describes a Movement and Place Hierarchy, along with overall spatial arrangements for each street type.

These include:

- road reserve width;
- carriageway width;
- arrangement of parking;
- provision and arrangement of cycle facilities;
- provision and arrangement of street tree canopy and street gardens

These typologies guide the overall design of the street arrangement as an integrated landscape architectural and civil design exercise. Section 2.3 of this manual guides the general provision and arrangement of street elements such as street furniture and lighting.

Section 3.0 of this manual – Elements and Details then guides the detailed placement and installation of individual elements for each of the street types and place hierarchies.

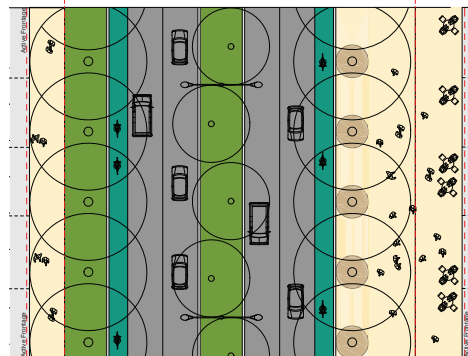
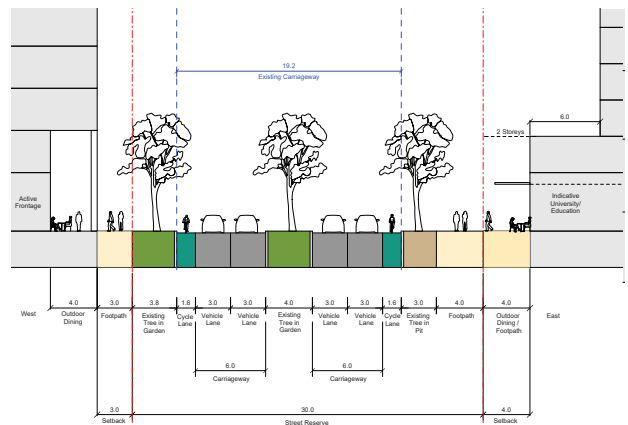

Spatial Arrangement Example: Edwin Flack Neighbourhood Connector Avenue (Main Street)
Source: Sydney Olympic Park Master Plan 2050

Figure 2.2.1 Street role and character plan



Source: Sydney Olympic Park Master Plan 2050

2.3 Street Structure

Streets are the living heart of urban infrastructure, supporting a wide range of functions including vehicular movement, pedestrian and cycle movement, green infrastructure, stormwater drainage, utility servicing, as well as community street life and commercial activity. Well-designed streets contribute not only to mobility, but also to the social, environmental, and aesthetic quality of urban environments.

Street Structure at a Glance

1. Property line

Is the boundary between the public and private domains.

2. Road reserve

Is the dedicated space for road infrastructure between property boundaries managed as Private Road or in NSW as either as State Road or Local Road.

3. Carriageway

Caters for vehicular movement and parking.

4. Parking lane

Is the zone to the edge of a carriageway where vehicles can be parked.

5. Footpath (for guidance refer Section 2.4 Elements placement principles)

The pedestrian zone providing safe and accessible movement and accommodating amenities such as street furniture, lighting, and signage, enhancing the comfort usability and safety of the public domain.

To manage the functionality of the footpath, it typically organised into three key zones:

Pedestrian clear path of travel

Is the unobstructed pedestrian movement zone of the footpath, designed in compliance with AS 1428.1 to ensure accessibility for all users. For the Sydney Olympic Park public domain, a **2m minimum** clear path of travel is applied across the whole site. The clear path of travel is generally provided along the adjoining property line and building frontage.

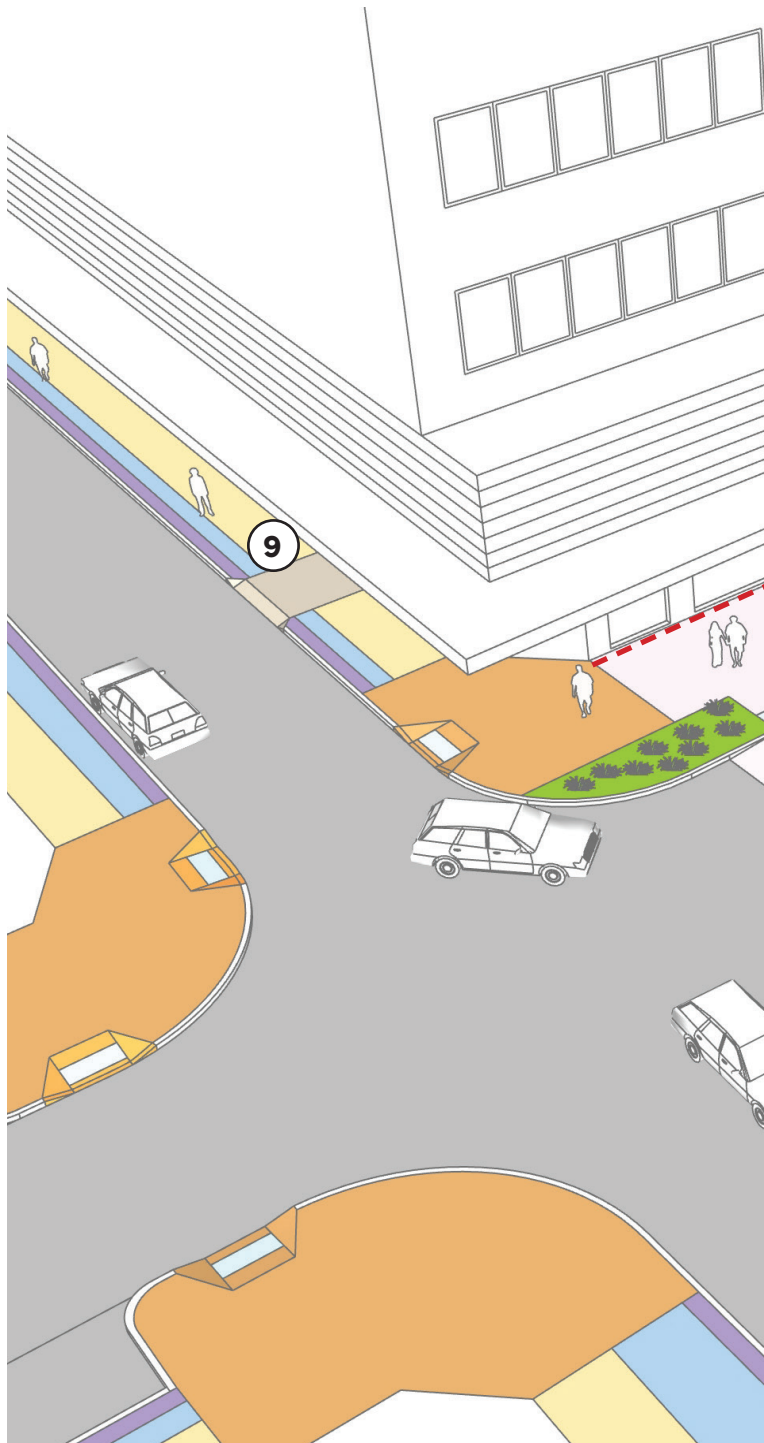

Egress zone

Is typically the zone between the kerbside parking lane and the furniture zone. It provides adequate and safe clearance for the doors of parked vehicles to open and for passengers to exit vehicles. For the Sydney Olympic Park public domain, a **0.6m wide** egress zone is applied across the whole site.

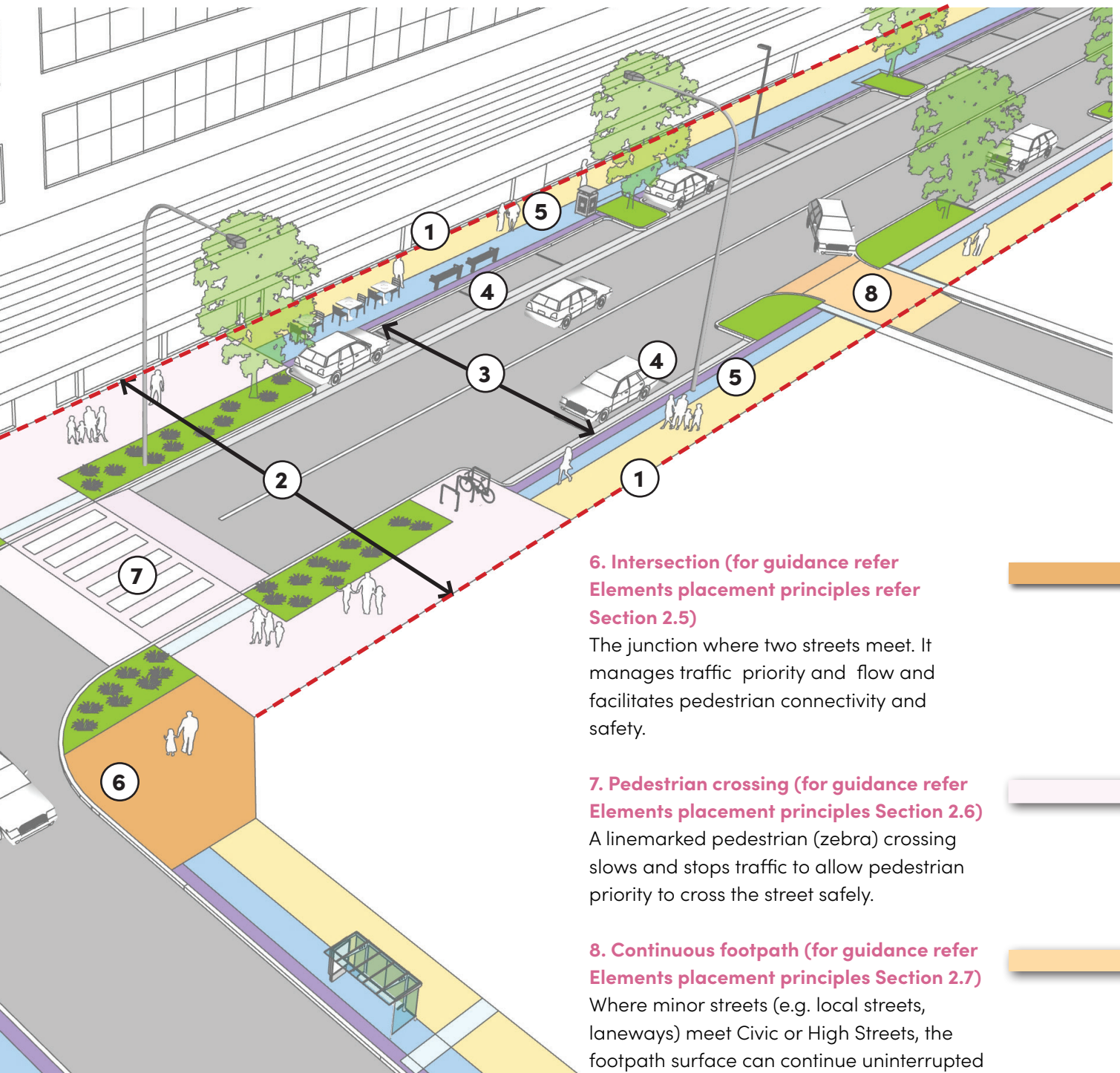

Furniture zone

Is typically the zone between the pedestrian clear path of travel and the egress zone. The Furniture zone accommodates public domain elements that support the function and use of the street such as street furniture, lighting and street trees and gardens. The furniture zone ensures furniture does not impede pedestrian movement, car egress and vehicular overhangs (eg buses).

6. Intersection (for guidance refer Elements placement principles refer Section 2.5)

The junction where two streets meet. It manages traffic priority and flow and facilitates pedestrian connectivity and safety.

7. Pedestrian crossing (for guidance refer Elements placement principles Section 2.6)

A linemarked pedestrian (zebra) crossing slows and stops traffic to allow pedestrian priority to cross the street safely.

8. Continuous footpath (for guidance refer Elements placement principles Section 2.7)

Where minor streets (e.g. local streets, laneways) meet Civic or High Streets, the footpath surface can continue uninterrupted across the junction to prioritise pedestrian movement along the major street and enhance accessibility and safety.

9. Driveway crossing (for guidance refer Elements placement principles Section 2.8)

Is located in the footpath and provides for private access to properties and basement parking. It should be designed for pedestrian priority, and continuity of footpath character.

2.4 Footpath Arrangement

Footpath

Thoughtful arrangement of public domain elements is essential to ensuring optimum movement, accessibility and safety of footpaths. When effectively arranged and integrated, these elements support a comfortable and user-friendly pedestrian experience.

Following in 2.4.1–2.4.3 are three scenarios illustrating typical spatial arrangements and placement of public domain elements within different footpath conditions.

Detailed elements arrangement must be subject to site specific design for each site situation:

2.4.1 Fully Paved Footpath Elements Placement Principles

1. Footpath design must comply with AS 1428 standards to ensure accessibility for all users.
2. Incorporate setback from face of kerb (0.6m) to face of elements facilitating egress zone for car doors to open and passengers to exit vehicles comfortably and safely.
3. A minimum 2.0-metre-wide unobstructed path of travel must be maintained at all times. This includes allowances required for equitable access.
4. The placement of elements within the footpath should follow the order below:
 - i. Trees
 - ii. Lights
 - iii. Street furniture

Note: the location of lightings and trees must be considered in relation to one another, as their placement is interdependent.
5. Trees should be aligned with the linemarking of parking spaces where possible to ensure vehicle doors can open fully and passengers can exit without obstruction. Additionally, thoughtful tree placement can contribute to increasing overall canopy coverage, enhancing shade and improving the street's environmental quality.
6. A minimum 3.0-metre clearance must be maintained between tree centre / trunk and street lighting poles.
7. Street furniture should be clustered where possible to reduce clutter. Arrangement requirements are as shown in Figure 2.4.2 and Section 3 guidelines.
8. Ensure fair distribution and logical sequencing of street furniture along the footpath.
9. Maximum spacing between rest areas (seats) to be 100m in urban area, or as determined by the Authority.

10. Place furniture where it will be used.
11. Outdoor dining arrangements shall be subject to available footpath width and a series of offsets to other uses and for effective and safe circulation. Refer Sydney Olympic Park Outdoor Dining Policy 2025 for full details.
12. For footpaths wider than 3.7 metres, any outdoor dining zone should be located on the kerb side.
13. For footpaths between 3.0 and 3.7 metres wide, dining zones should be positioned against the building facade, allowing adequate space for building entries and pedestrian movement.
14. The outdoor dining zone should maintain a minimum clearance of 0.7m from the kerb, other street elements and minimum 2.4m from bus stops, taxi ranks, accessible parking, and post boxes.
15. The outdoor dining zone should maintain a minimum 2.0-metre clearance between dining areas to facilitate pedestrian circulation.
16. Electrical and telecommunication pillars are not acceptable on the footpath and must be outside of the paved areas, either within private property or landscaped areas.

Figure 2.4.1 Typical Footpath Zones

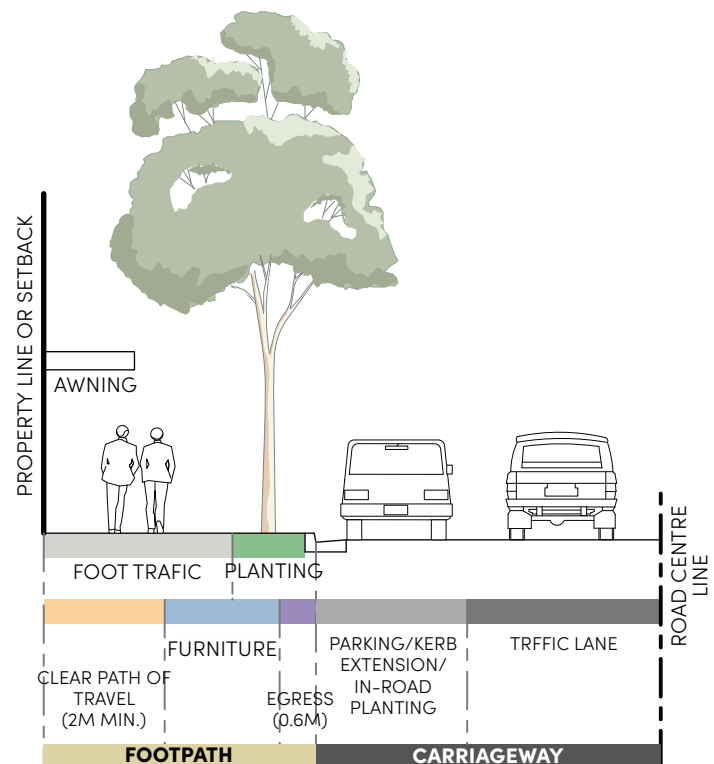

2.4 Footpath Arrangement (Cont.)

2.4.2 Footpath with Landscape Verge Elements Placement Principles

1. Footpath design must comply with the AS 1428 standards to ensure accessibility for all users.
2. Incorporate setback from face of kerb (0.6m) to face of elements facilitating egress zone for car doors to open and passengers to exit vehicles comfortably and safely.
3. A minimum 1.8-metre-wide unobstructed path of travel must be maintained at all times. This includes allowances required for equitable access.
4. The placement of elements within the footpath should follow the order below:
 - i. Trees
 - ii. Lights
 - iii. Street furniture

Note: the location of lightings and trees must be considered in relation to one another, as their placement is interdependent.
5. Tree spacing should, where possible, be coordinated with the arrangement of parking spaces to ensure that vehicle doors can open fully and passengers can exit safely without obstruction. Additionally, thoughtful tree placement can contribute to increasing overall canopy coverage, enhancing shade and improving the street's environmental quality.
6. A minimum 3.0-metre clearance must be maintained between tree centre / trunk and street lighting poles.
7. Street furniture should be clustered where possible to reduce clutter. Arrangement requirements are as shown in Figure 2.4.3 and Section 3 guidelines.
8. Ensure fair distribution and logical sequencing of street furniture along the footpath.
9. Maximum spacing between rest areas (seats) to be 100m in urban area, or as determined by the Authority.
10. Place furniture where it will be used.
11. Electrical and telecommunication pillars are not acceptable on the footpath and must be outside of the paved areas, either within private property or landscaped areas.

Figure 2.4.3 Typical Landscaped Verge Footpath Arrangement

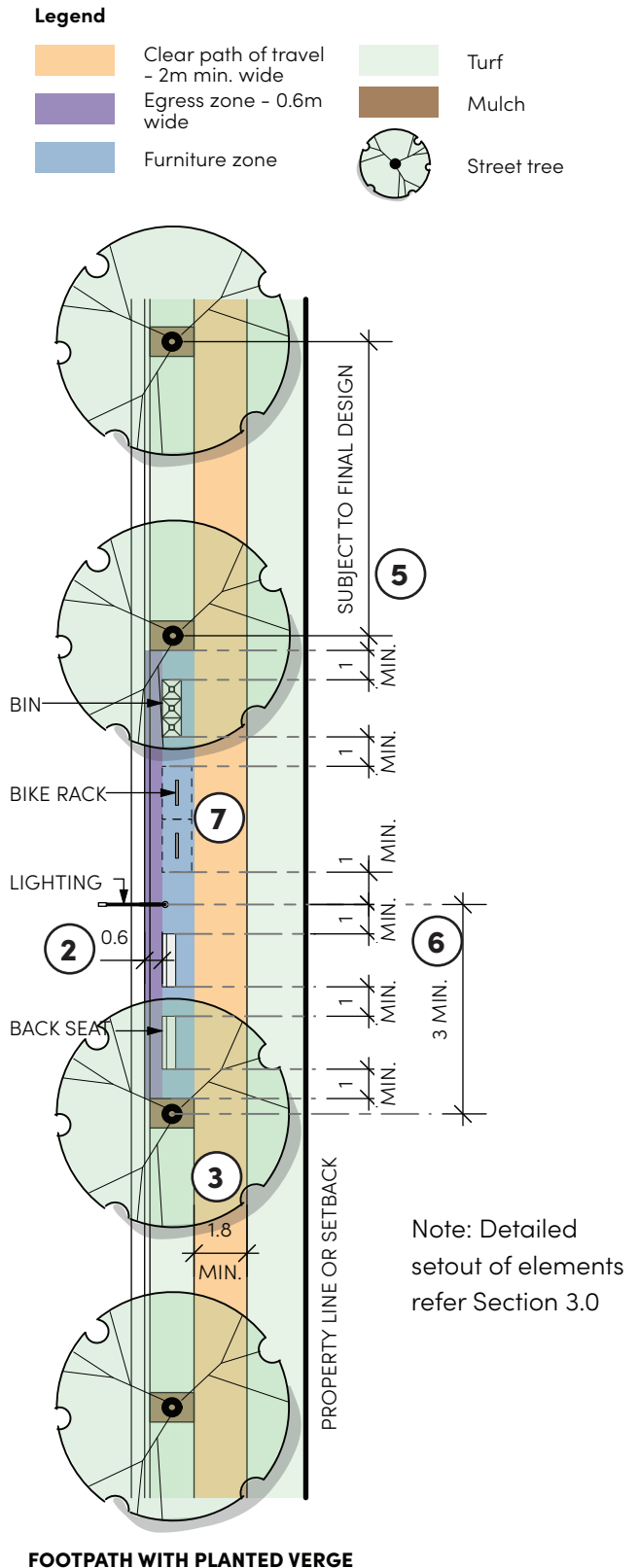

2.5 Intersection Arrangement

Intersections

Effectively designed intersections reinforce the street hierarchy and are key nodes for pedestrian connectivity, wayfinding, amenity and safety. The following principles apply to intersections generally throughout Sydney Olympic Park:

- Pedestrian amenity and enhanced urban design outcomes are to be considered as primary priorities for design, while at the same time addressing necessary traffic requirements;
- Civic and High Streets should take precedence at intersections, with the pavement carried through the intersection to the start of parking on the secondary street;
- Kerb ramps are to align across the street in accordance with AS1428 requirements, and Sydney Olympic Park Authority IECM details;
- Placement of elements are to comply with site specific sight line requirements identified by the traffic engineer;
- Standard kerb radii of 3, 6 and 9m to be applied, subject to site specific traffic / swept path requirements determined by traffic engineer;
- Street lights are generally to be located integrated and coordinated with other elements to meet required standards;
- Lighting arrangement is subject to final site specific design by lighting consultant, and
- Regulatory signs and line marking are subject to final site specific engineering design.

Intersection Elements Placement Principles

1. Place kerb ramps in larger streets in accordance with AS1428 requirements – generally align the edge of the ramp with the edge of footpath or building.
2. Place kerb ramps in smaller streets on required alignment – where there is insufficient room to achieve the above, align edge of ramp with tangent point of intersection curve.
3. Align unit pavement coursing at 90 degrees to kerb line.
4. Install tactile ground surface indicators at kerb ramps in accordance with the arrangement and specifications in Section 3.1.
5. Consider a chamfer or radius to the corner of garden beds adjoining kerb ramps where required to facilitate ease of pedestrian movement.
6. Place street name sign on light poles.
7. Place street lights at intersections 1m min. from edge of kerb ramp and 0.6m min. from face of the kerb.
8. Street trees should be positioned min. 10m from face of the intersection kerb line on the approach side and min. 7m on the non-approach side of crossing points – assess site specific site line requirements prior to finalisation of design.
9. The street trees and light poles must be designed in a way that the tree canopy and the streetlight have minimum interference and tree canopy does not block the light.
10. Outdoor dining zones should be 3m min. distance from street corner or kerb ramp, whichever is greater.

Figure 2.5.1 Typical Intersection Arrangement

Note: Detailed setout of elements refer Section 3.0

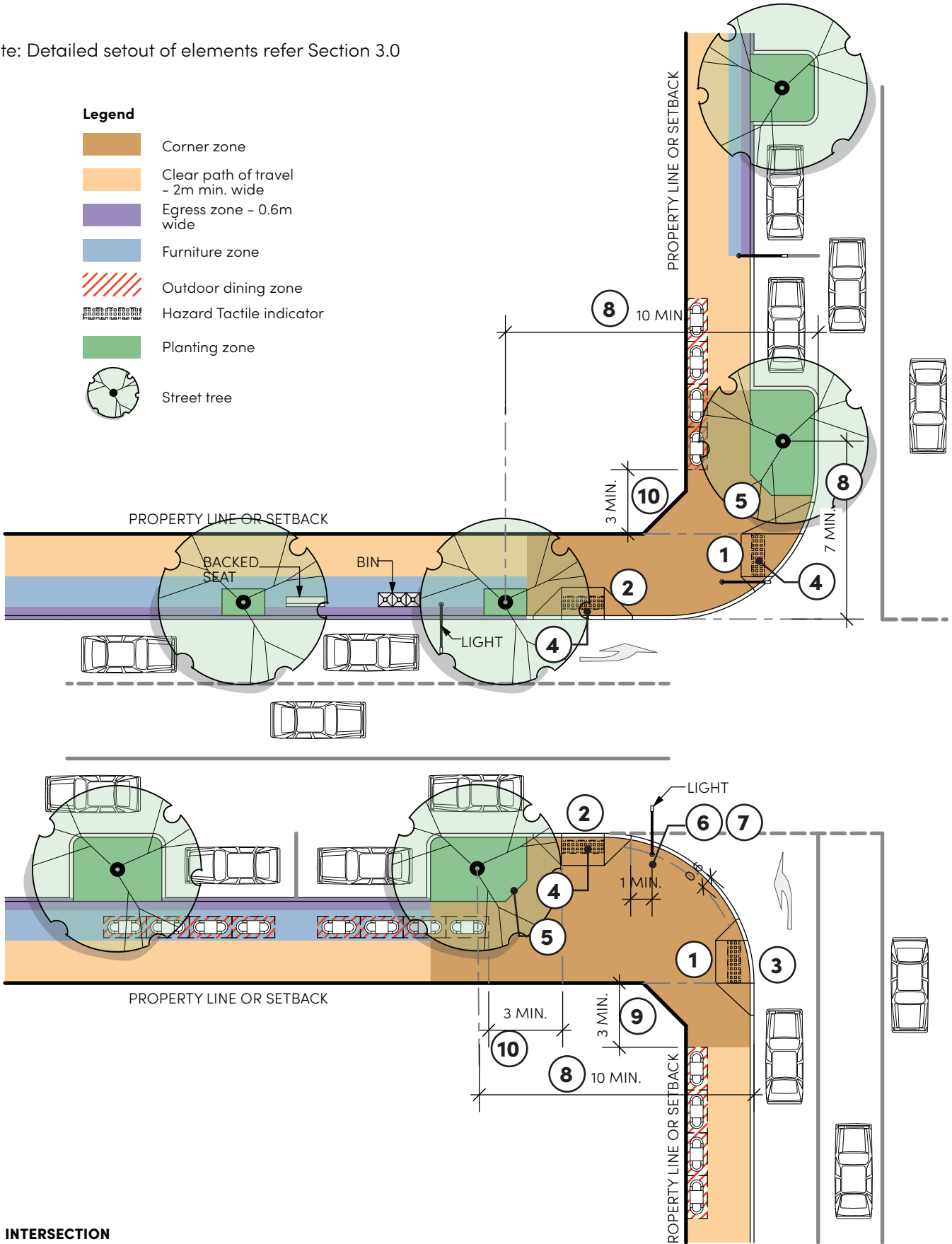

INTERSECTION

2.6 Pedestrian (Zebra) Crossing Arrangement

Pedestrian Crossing

A linemarked (zebra) pedestrian crossing provides pedestrian priority at key pedestrian crossing points. Pedestrian crossings play a critical role in promoting walkability, enhancing pedestrian safety, integrating urban centres and supporting accessibility.

The following principles apply to pedestrian crossings generally throughout Sydney Olympic Park:

- Pedestrian amenity and enhanced urban design outcomes are to be considered as primary priorities for design, while at the same time addressing necessary traffic requirements;
- Integration of appropriate urban elements (such as furniture and planting) into pedestrian crossing design to Civic and High Streets streets;
- Pedestrian crossing design should address Austroads and RMS design standards and compliancy requirements;
- Kerb ramps are to align across the street in accordance with AS1428 requirements, and Sydney Olympic Park Authority IECM detail;
- Integrate traffic claiming devices into streetscape design to slow down the traffic and optimise use of no stopping zones either side of crossing (for example kerb extension with street tree and garden planting);
- Placement of elements are to comply with sight line requirements as identified in site specific design by traffic engineer;
- Lighting arrangement is subject to final design by lighting consultant; and
- Regulatory signs and line marking are subject to final site specific engineering design.

Pedestrian Crossing Elements Placement Principles

1. Provide kerb extension within no stopping zones adjacent to the pedestrian crossing, incorporating garden beds, tree plantings and street furniture. Refer to the guiding dimensions illustrated in Figure 2.6.1 on the next page and table below.
2. Integrate street furniture at major pedestrian crossing points to provide a gathering hub and enhance public amenity.
3. Install tactile ground surface indicators at kerb ramps or raised crossings in accordance with the arrangement and specifications in Section 3.1.
4. Consider a chamfer or radius to the corner of garden beds where required to facilitate ease of pedestrian movement.
5. Locate street trees a minimum of 10 metres from the pedestrian crossing on the approach side to maintain clear sight lines for oncoming traffic and ensure pedestrian safety.
6. The street trees and light poles must be designed in a way that the tree canopy and the streetlight have minimum interference and tree canopy does not block the light.
7. Any outdoor dining zone should maintain a minimum clearance of 5m from the pedestrian crossing.







Z (Width of extensions)	X (no stopping at approaching side)	Y (no stopping at non-approaching side)
0m	20m	10m
1.5m	15m	10m
2m	10m	10m
2.5m	At Tangent point of kerb extension and kerb line or 7.5m whichever is greater	At Tangent point of kerb extension and kerb line or 7.5m whichever is greater

No Stopping Zone & Kerb Extensions at Pedestrian Crossing (Refer TfNSW Technical Directions for more details)

Figure 2.6.1 Typical Pedestrian Crossing Arrangement

Note: Detailed setout of elements refer Section 3.0

Legend

-  Crossing zone
-  Footpath
-  Outdoor dining zone
-  Tactile indicator
-  Planting zone
-  Street tree

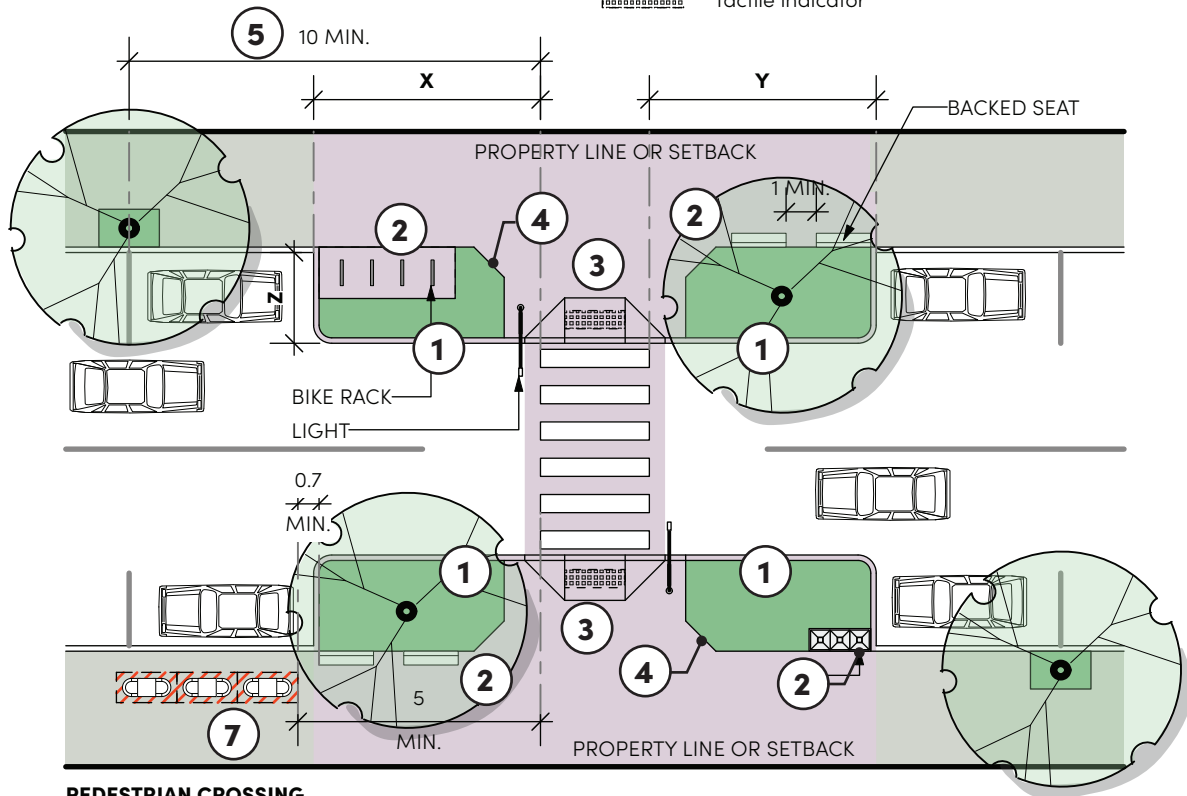

PEDESTRIAN CROSSING

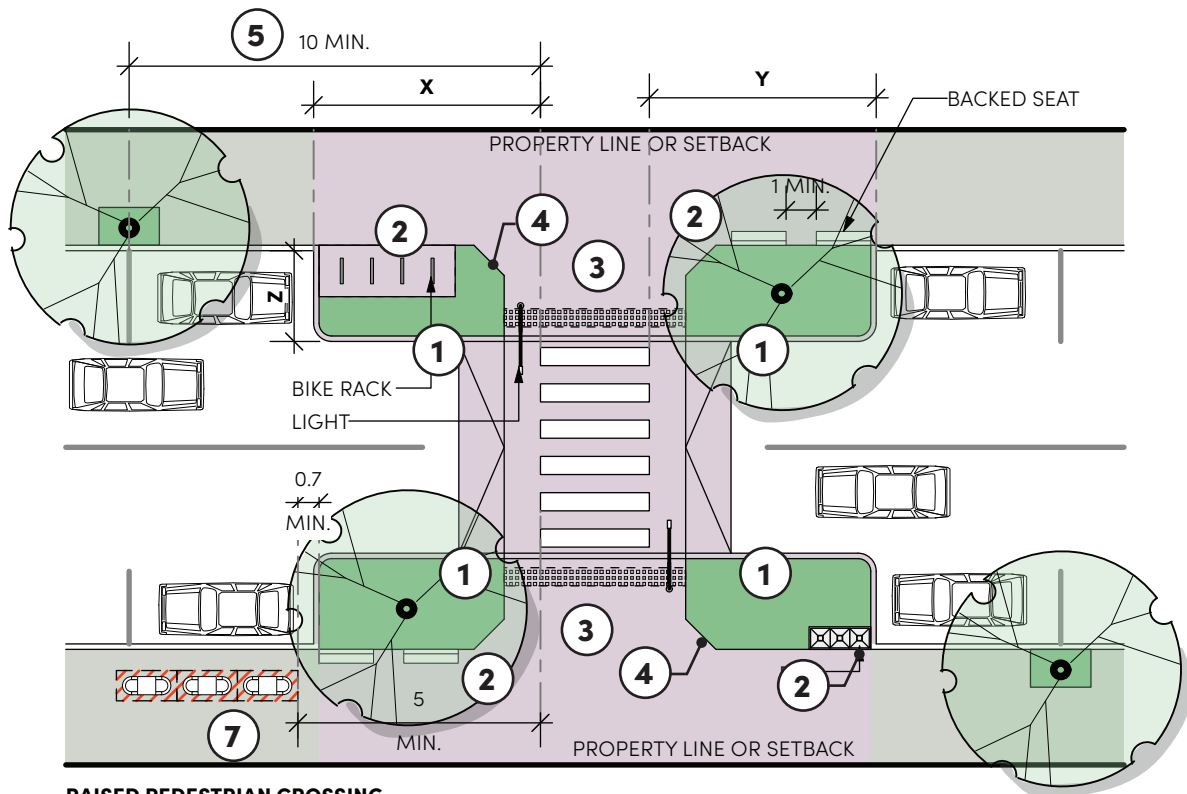

RAISED PEDESTRIAN CROSSING

2.7 Continuous Footpath Arrangement

Continuous Footpath

Where secondary streets with low vehicle volumes (e.g. laneways) intersect with Civic or High Streets, a continuous footpath treatment (raised threshold) may be used to prioritise pedestrian movement and enhance both accessibility and safety.

The following principles apply to continuous footpath treatments throughout Sydney Olympic Park:

- Pedestrian amenity and enhanced urban design outcomes are to be considered as primary priorities for design, while at the same time addressing necessary traffic requirements;
- Continuous footpath design should address Austroads and RMS design standards and compliancy requirements;
- Placement of elements are to comply with site specific sight line requirements identified by the traffic engineer;
- Lighting arrangement is subject to final design by lighting consultant; and
- Regulatory signs and line marking are subject to final site specific engineering design.

Continuous Footpath Elements Placement Principles

1. Provide site specific Traffic Engineers advise to confirm requirements for no stopping zones either side of road junction;
2. Provide kerb extensions to the Civic Street or High Street within no stopping zones adjacent to the junction, incorporating garden beds and tree plantings.
3. Continue adjoining Civic Street or High Street pavement surface through threshold to visually maintain footpath and/or cycle path continuity;
4. To unit paved thresholds, apply vehicular trafficable small format pavement to match adjoining finish with structural grout on concrete base.
5. Install tactile ground surface indicators at raised thresholds in accordance with the arrangement as per Figure 2.7.1 and guidelines in Chapter 3.0;
6. Locate street trees a minimum of 10 metres from the junction on the approach side, to maintain clear sight lines for oncoming traffic and enhance pedestrian safety;
7. Any outdoor dining zone should maintain a minimum clearance of 2m from the continuous footpath threshold.

Figure 2.7.1 Typical Continuous Footpath Arrangement

Note: Detailed setout of elements refer Section 3.0

Legend

- Footpath
- Crossing zone
- Bike lane
- Crossing zone
- Outdoor dining zone
- Tactile indic
- Planting zone
- Street tree

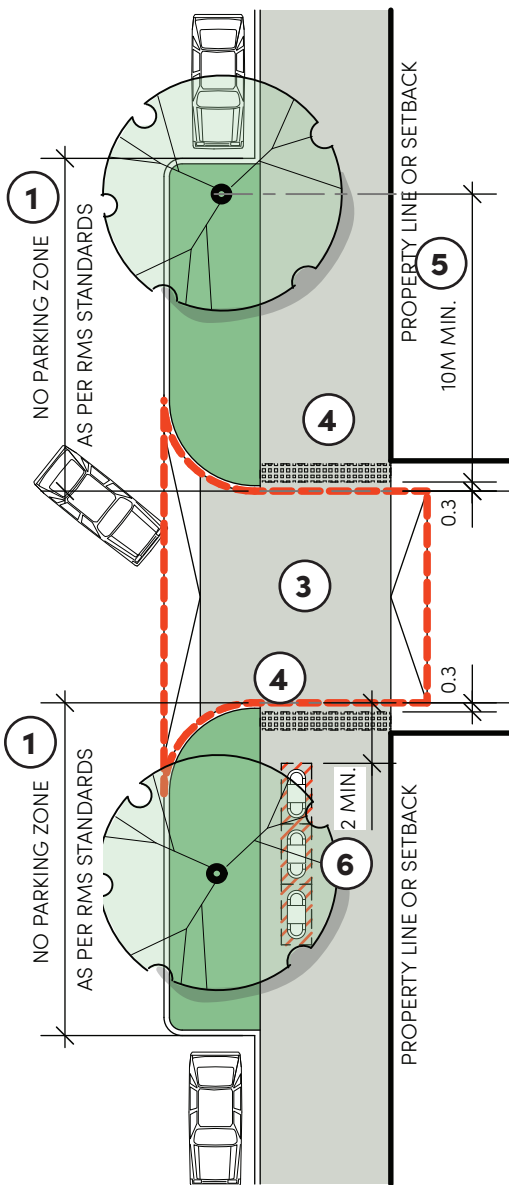

CONTINUOUS FOOTPATH TREATMENT

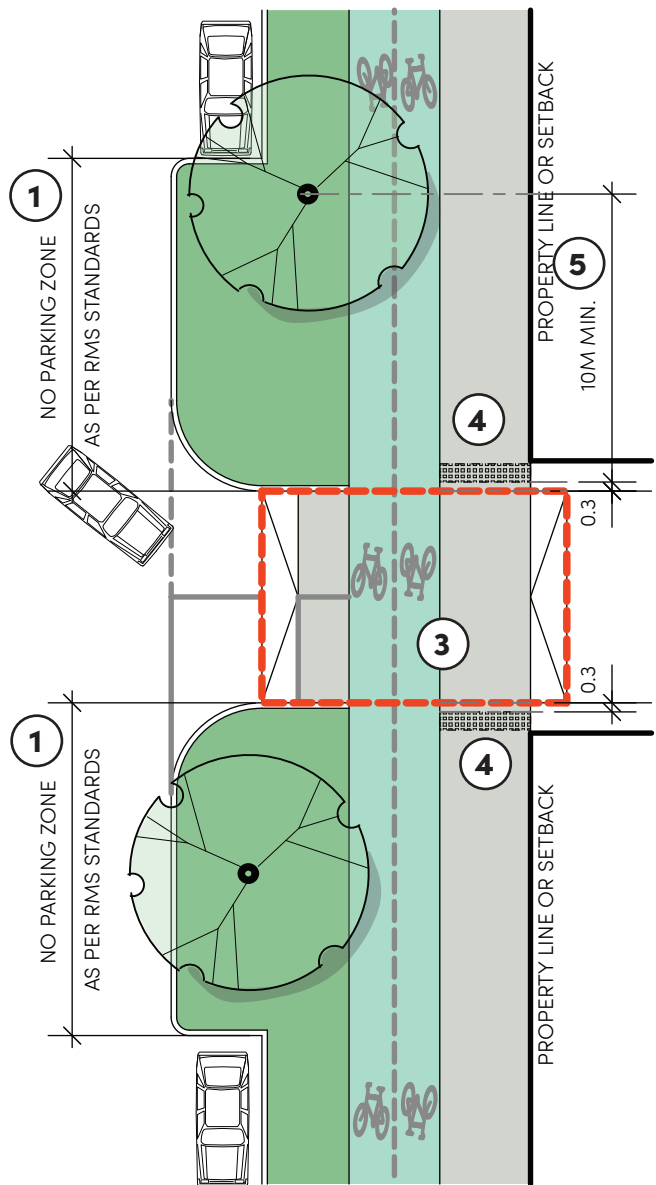

CONTINUOUS FOOTPATH TREATMENT - WITH BIKE LANES

2.8 Driveway Arrangement

Driveway Crossing

Driveways provide necessary vehicular transitions from the street into private property. Driveways may serve for private access only or may cater for broader use such as servicing and deliveries and public parking in basements or rooftops.

The following principles apply to driveway crossing throughout Sydney Olympic Park:

- Pedestrian amenity and enhanced urban design outcomes are to be considered as primary priorities for design, while at the same time addressing necessary traffic requirements;
- Driveway design should address Austroads and RMS design standards and compliancy requirements;
- Driveway kerb crossings are to align across the street in accordance with Sydney Olympic Park Authority IECM details;
- Placement of street elements must comply with site specific sight line requirements as identified by the traffic engineer;
- Lighting arrangement is subject to final design by lighting consultant; and
- Regulatory signs and line marking are subject to final site specific engineering design.

Driveway Elements Placement Principles

1. Continue adjoining street footpath pavement surface through driveway to visually maintain footpath continuity.
2. Apply vehicular trafficable small format pavement to match adjoining finish with structural grout on concrete base. Refer Section 3.1 Pavements and Level changes for details.
3. Locate street trees a minimum of 3 metres from the driveway crossing on the approach side and 2m on non-approach side to maintain clear sight lines for oncoming traffic and enhance pedestrian safety.
4. Any outdoor dining zone should maintain a minimum clearance of 2m from the driveway crossing.

Figure 2.7.1 Typical Continuous Footpath Arrangement

Note: Detailed setout of elements refer Section 3.0

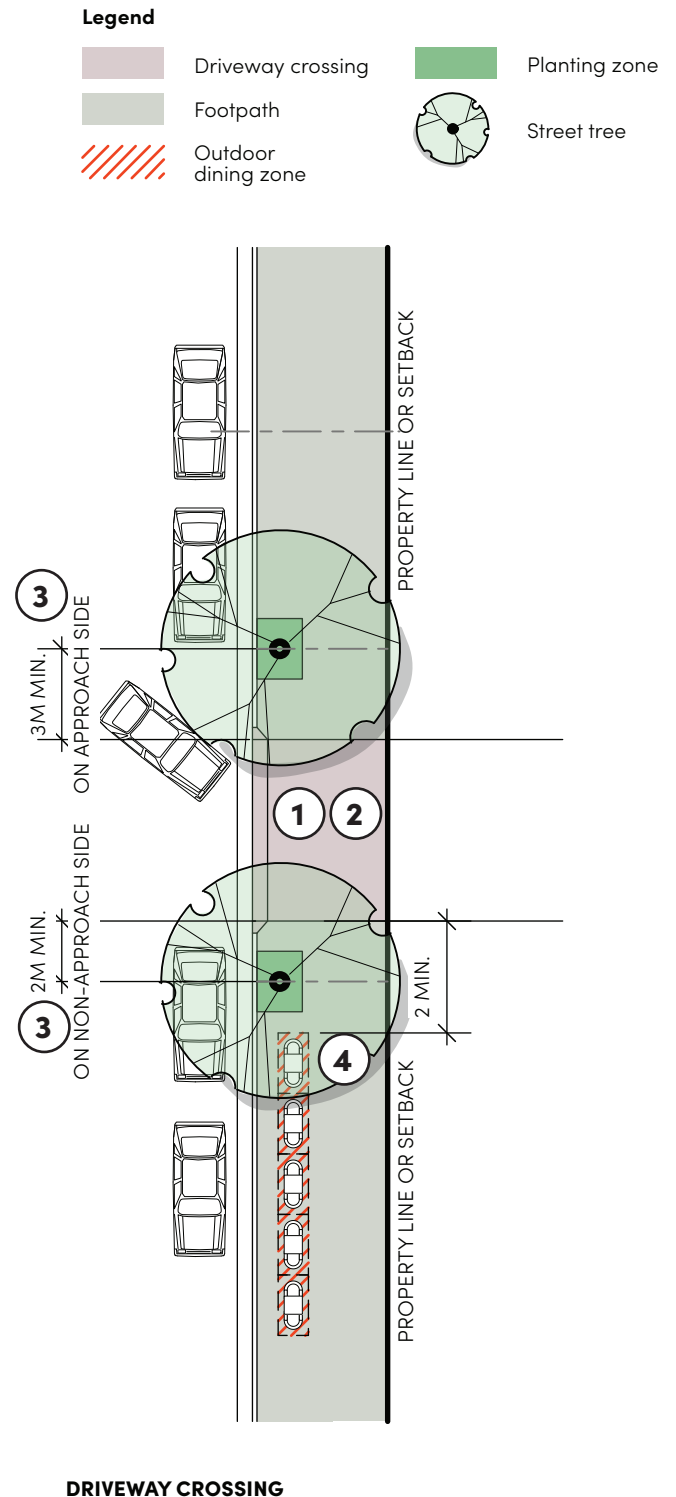

Sydney Olympic Park Design Manual

**ELEMENTS AND
DETAILS**

3.0

The design manual applies a consistent and legible approach to design of streets, urban spaces and parks, and is curated as a co-ordinated suite of elements.

A curated approach to design and finishes helps shape the character and identity of Sydney Olympic Park, facilitates use and enjoyment of the public domain and supports environmental sustainability and cost efficiency.

The paving approach reflects the Master Plan 2050 street hierarchy, and is based on the public domain role and function of each street type.

Accessibility has been a primary consideration in the detailing of pavements, kerbs and their finishes.

The lighting guidance incorporates standard light fittings as defined by the separate Lighting Strategy on purpose-designed poles in the existing areas and off the shelf poles in local streets.

Street furniture combines a number of standard manufactured items with some purpose designed elements. Each has been selected to ensure its place within the system.

Planting defines requirements for street and parkland tree plantings in addition to gardens and mass planting. Recommended species lists are provided.

Signage is defined in the Separate Sydney Olympic Park Signage Guidelines.

3.0 Elements and Details

The Public Domain Elements at Sydney Olympic Park reflect the area's unique character, development history, and environment. They are selected and designed to meet a variety of functional needs, including everyday accessibility and use, event operations, and ongoing maintenance. Additionally, they should contribute to environmental sustainability.

Public Domain Elements must support equal access for all users, ensuring an appropriate level of amenity during both high crowd flows and day-to-day use. Their selection is guided by key principles, including high quality, durability, consistency, environmental sustainability, and ease of maintenance.

Public Domain Elements

1. Pavements and level changes (refer Section 3.1)

The paving design aligns with the street hierarchy outlined in the Master Plan 2050. Pavement is usually one of the key elements establishing a distinctive and memorable visual identity for an area, especially in urban context. Accessibility has been a central consideration in the detailing of pavements, kerbs, and surface finishes, ensuring that the public realm is inclusive and navigable for all users.

2. Furniture (refer Section 3.2)

Street and Park furniture plays a critical role in the functionality, identity and experience of public spaces. It includes elements like seats, picnic tables, bins, bike racks, bollards and drinking fountains. When thoughtfully selected and strategically placed, street furniture fosters a sense of place, encourages social interaction, and strengthens the connection between people and the public realm.

3. Shelter structure (refer Section 3.3)

Shelter structures are essential components of the public realm, providing protection from sun, rain, and wind, while also enhancing the usability and comfort of outdoor spaces.

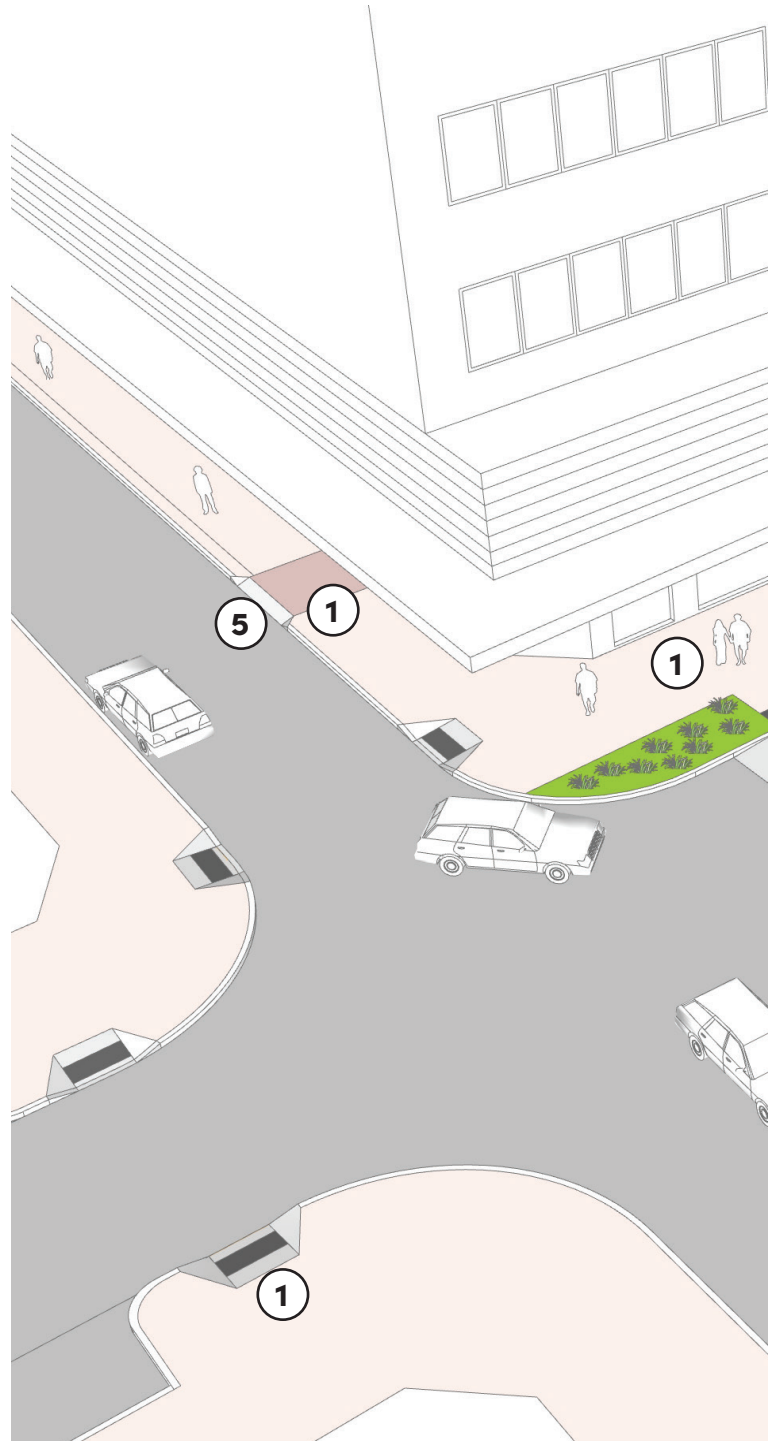

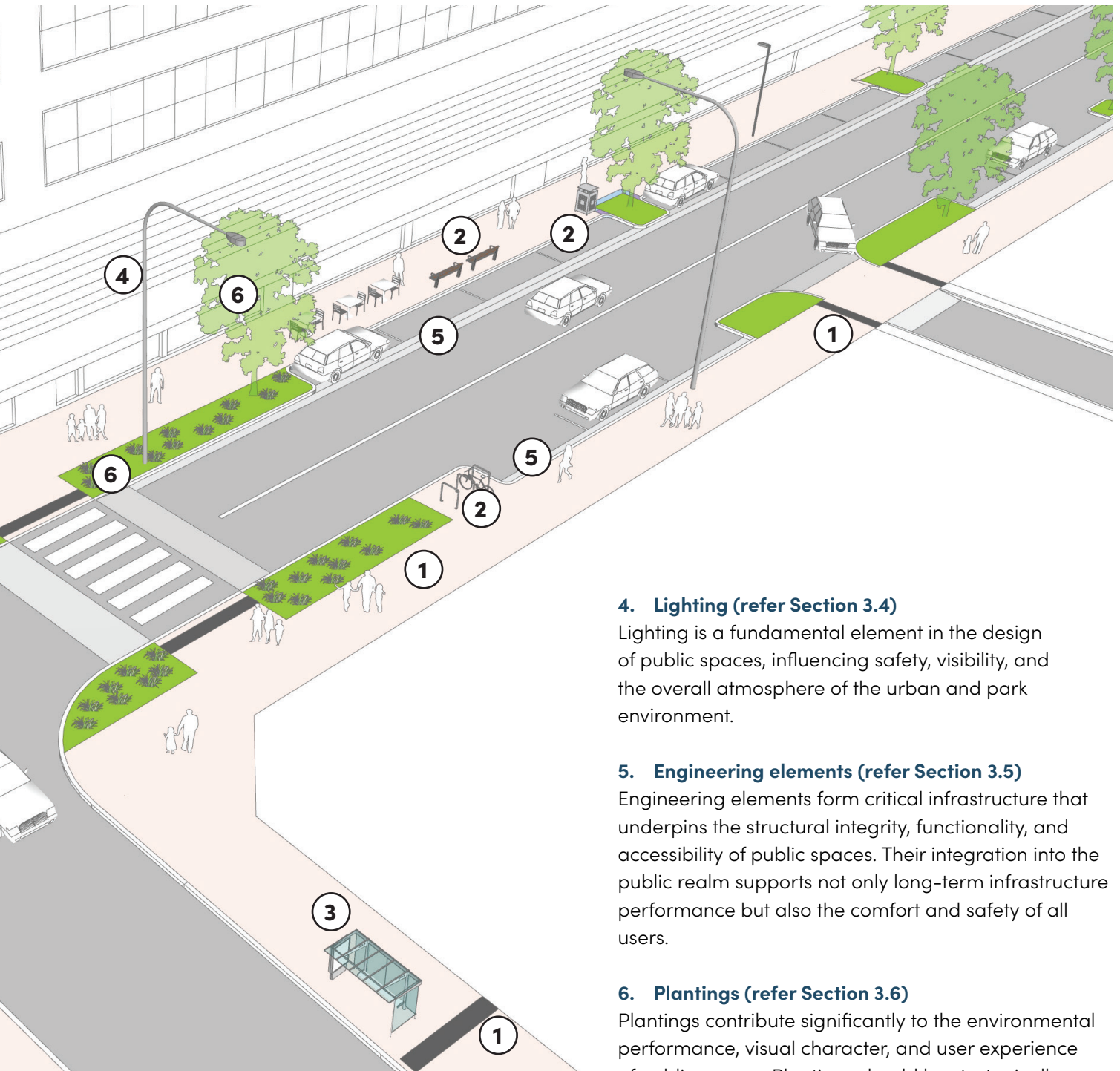

4. Lighting (refer Section 3.4)

Lighting is a fundamental element in the design of public spaces, influencing safety, visibility, and the overall atmosphere of the urban and park environment.

5. Engineering elements (refer Section 3.5)

Engineering elements form critical infrastructure that underpins the structural integrity, functionality, and accessibility of public spaces. Their integration into the public realm supports not only long-term infrastructure performance but also the comfort and safety of all users.

6. Plantings (refer Section 3.6)

Plantings contribute significantly to the environmental performance, visual character, and user experience of public spaces. Plantings should be strategically selected and designed to enhance biodiversity, provide shade and microclimate regulation, and soften the built environment.

Sydney Olympic Park Design Manual

PAVEMENTS AND LEVEL CHANGES

3.1

Footpaths, pathways and pavements provide a unifying canvas to the public domain connecting built form, movement and servicing, and enhancing community and street life.

This is achieved through a co-ordinated and carefully curated palette of paving materials supported by consistency of footpath dimensions levels, materials and finishes and edges across the different street types.

Across Sydney Olympic Park, the range of pavement materials are unified by a harmonious colour palette and continuity of detailing, including kerbs and kerb ramps and steps.

Pavements and related detailing in Sydney Olympic Park also provide clear expression of pedestrian priority and accessibility.

In particular this reinforces the important pedestrian movement role of the high activity spaces and streets such as pedestrian spaces, transit malls, Civic streets and High streets.

Guidelines include:

- pavement finishes
- kerb ramps
- steps
- access ramps
- tactile indicators
- pit lid finishes
- trench grates
- general landscape walls
- edging

3.1 Pavements and Level Changes

3.1.1 Objectives

The selection and detailing of paving materials at Sydney Olympic Park is designed to achieve the following objectives:

- visually co-ordinate the public domain;
- create a continuous ground plane upon which people, buildings and movement provide variation and change;
- provide legibility of different paving types;
- clearly delineate pedestrian and vehicular zones;
- use a minimal and consistent palette of materials;
- achieve environmental principles adopted for the site; and
- minimise the life cycle costs and maintenance requirements.

3.1.2 Paving

The existing paving palette will be retained to preserve the current character of the area. However, new paving materials, such as granite, will be introduced to accommodate new functional requirements, including light rail transit.

The street hierarchy outlined in Master Plan 2050 establishes the framework for the use and selection of paving materials. For further details, refer to Section 3.1.7.

3.1.3 Procurement

Procurement of urban elements must comply with the NSW Government's procurement policies.

3.1.4 Footpath Accessibility

Footpath design must be in accordance with Australian Standard requirements for equal access and pedestrian safe movement. The following standards apply to public footpaths design within the site:

- AS 1428.1-2009 Australian Standard Design for Access and Mobility Part 1: General requirements for access - new building work
- AS 1428.2-1992 Australian Standard Design for Access and Mobility Part 2: Enhanced and additional requirements - Buildings and facilities
- AS/NZS 1428.4:2002 Australian/New Zealand Standard Design for Access and Mobility Part 4: Tactile indicators

- DSAPT (Disability Standards for Accessible Public Transport) 2002
- DDA (Disability Discrimination Act) 1992

Clear Path of Travel

In all footpaths within Sydney Olympic Park, it is essential to maintain clear path of travel free of furniture or other obstructions to ensure smooth and safe pedestrian flow. Comply with the Authority's standards for the minimum Clear Path of Travel:

- 2m in width in Urban Area;
- 1.8m in width in urban parks;
- 3m in width on cycleways or pedestrian/ cycle shared paths and in parklands;
- 2m in height in both Urban and Parklands Area.

Also refer Section 2.3 & 2.4 for more details.

Gradients and Cross Falls

To ensure footpath accessibility and effective stormwater drainage away from buildings, appropriate cross falls must be incorporated into public footpath design:

- Footpath design should avoid level change between footpath and the building setback wherever possible;
- Where there are no level changes between the building setback and the public footpath, the paving type on footpath is to be extended within the building setback to meet building line;
- Consistent cross falls should be provided where achievable;
- Cross falls along the path of travel must be a minimum of 1% for drainage and a maximum of 2.5% for accessibility compliance, refer Figure 3.1.1;
- Where consistent cross falls within 2.5% cannot be achieved, ensure the Clear Path of Travel does not exceed 2.5%, with a maximum of 5% cross fall allowed between the Clear Path of Travel and the top of kerb, refer Figure 3.1.1; and
- A continuous longitudinal fall should be maintained along both the property boundary and top of kerb alignments. Variations may be considered to accommodate existing site conditions, subject to design approval.

Figure 3.1.1 Typical Footpath Cross Fall

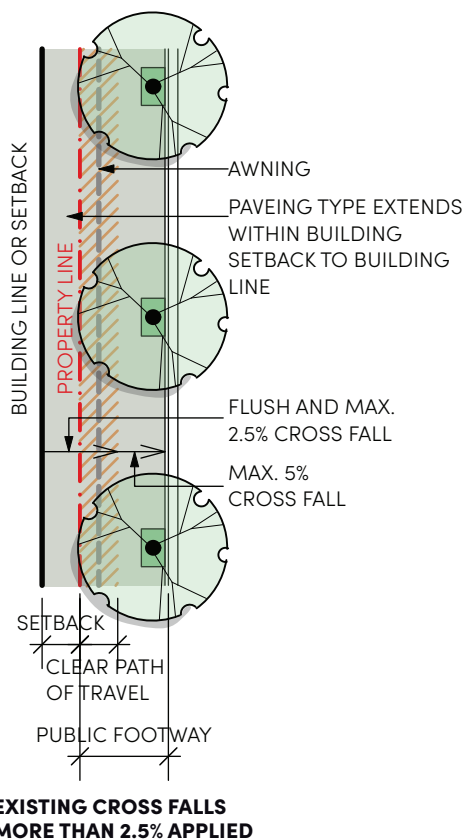
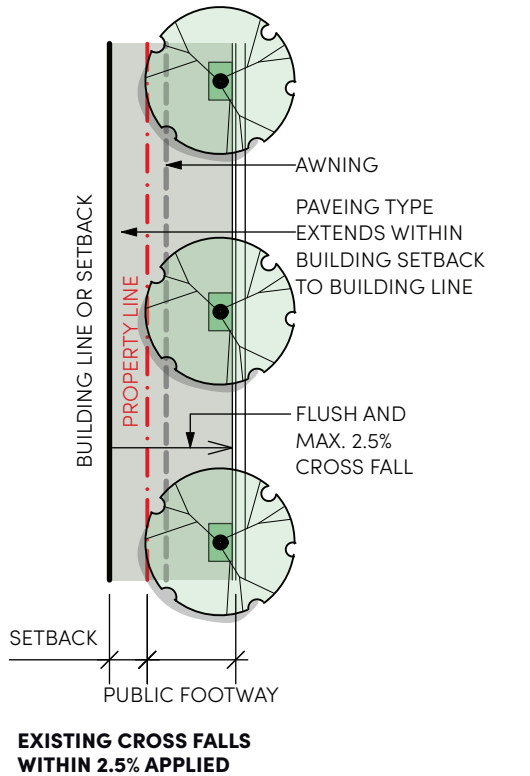

Level Changes at Building Interface

Although generally privately owned, the street-building interface impacts the visual quality of streetscape and the accessibility from public domain to private domain.





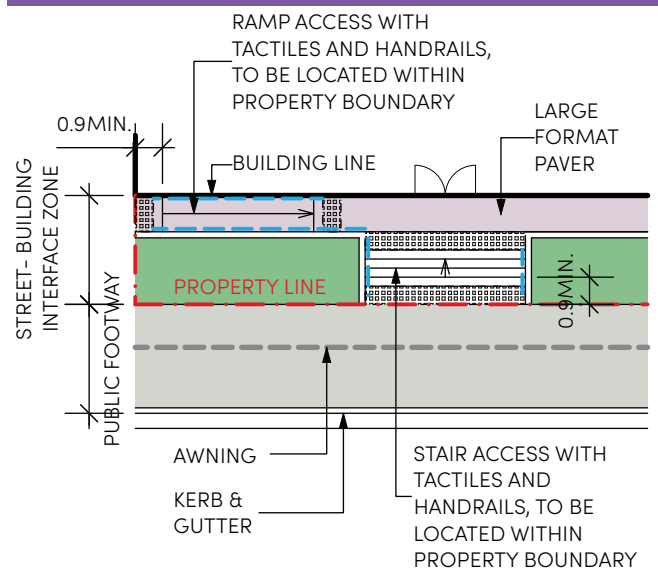

- Building finished floor levels (FFLs) should be set to support recommended footpath cross falls and provide a smooth transition between public and private land. Any necessary level adjustments for access should be made within the private land;
- Avoid floor level of building being set lower than adjacent footpath wherever possible;
- If level change is unavoidable between the building setback and public footpath, apply large format pavement (PL03) within building setback, refer Figure 3.1.2;
- Stairs and ramps to be used where a level change occurs to maximise permeability of the public domain;
- Ensure that all stairs and ramps meet the requirements in AS1428.1;
- Ensure that any external stairs and ramps end 900mm inside the property boundary to allow for handrails and TGSIs. Protrusion of stairs, ramps, handrails, and TGSIs into the Path of Travel is not permitted; and
- Ensure that any external stairs coordinate lowest landing with footpath level and that risers are of equal height for their full width.

Figure 3.1.2 Level Changes at Building Interface

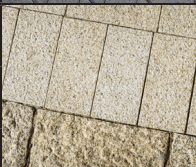

3.1 Pavements and Levels Changes

3.1.5 Paving Strategy

Footpath Paving Typology	Image	Reference Drawing No.	Street ID/ Location	Street Type	Urban Area (U)/ Parklands(P)
Large Format Pedestrian Paving <ul style="list-style-type: none"> Havenslab® 50 400x200x50mm Charcoal 		PL03	C7, C8, C9, C10, C12, C17	Civic Street	U
			H1	High Street	
			L27	Local Street	
			CS2, CS3, CS7	Connector Street	
			CA7 West, CA4	Connector Avenue	
Precast Pavers - Non Interlocking <ul style="list-style-type: none"> Brickpave® 80 225x112x80mm Charcoal/ Oatmeal/ Natural 		PL04/ PL06	As above/ driveway crossing	As above	U
			L20, L21	Local Street	
			CS4	Connector Street	
Precast Pavers - Interlocking <ul style="list-style-type: none"> Trihex® 80 188x92x80mm Charcoal/ Oatmeal/ Natural 		PL05	P2	Pedestrian Space	U
			C1, C16, C18	Civic Street	
			L3, L4, L5	Local Street	
			CS1, CS5	Connector Street	
Permeable Pavers <ul style="list-style-type: none"> Ecotrihex® 80 188x92x80mm Charcoal/ Natural 		PL08	As above/ in conjunction with Trihex paving and tree planting in stratavaults	As above	U
Precast Pavers Interlocking <ul style="list-style-type: none"> Unipave® 80 225x113x80mm Charcoal/ Steel/ Portblend 		PL05	C1, C16/Carriageway	Civic Street	U
Granite Pavers <ul style="list-style-type: none"> Honey Jasper Pavers @ 600x300x50mm Cobblestones @95x95x50mm Bush Hammered finish 		PL07	P1, P3, P4, P5, P6, P7, P8, P9, P10, P11, P12, P13, P14	Pedestrian Space	U
			HA1	High Activity Transit Mall	
			C20	Civic Street	
Asphaltic Concrete General		PL10	C2, C3, C5, C6, C11, C13, C14, C15, C19, C21	Civic Street	U/P
			L6, L7, L8, L9, L10, L11, L12, L13, L14, L15, L16, L17, L18, L19, L22, L23, L24, L25, L26	Local Street	
			CS6, CS8, CS9	Connector Street	
			CA1, CA2, CA3, CA5, CA6, CA7-1, CA7-2 East, CA7-3 East, CA7-4, CA8, CA9, CA10, CA11, CA12, CA13	Connector Avenue	
Concrete Pavement <ul style="list-style-type: none"> Exposed aggregate finish 		PL09	C4	Civic Street	U
			L1, L2	Local Street	

* Asphaltic Concrete Special (drawing PL10) and Concrete pavement broom finish (drawing PL09) placement to be advised by the Authority

Figure 3.1.3 Paving Strategy - Street ID Map



3.1 Pavements and Levels Changes

3.1.6 Pavements and Levels Changes Guidelines

Application

- Urban Area and Parklands
- Intersection where Pedestrian Space or Civic / High Street meets Local Street

Product/ Material

- Pavements to Project Landscape Architect's specification.

Supplier

To be advised.

Construction Notes

- Extend the pavement at Pedestrian Space or Civic / High Street towards Local Street by 10 meters from the tangent point where the curve transitions.

Paving Interface at Intersection

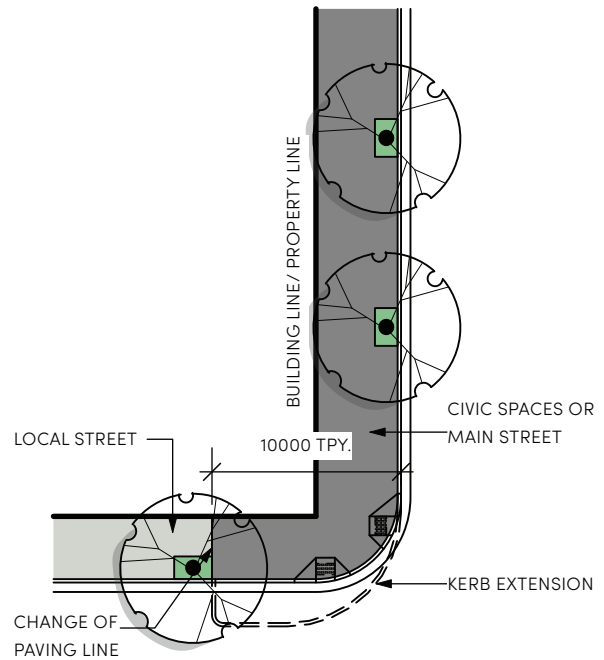

TYPICAL PAVING INTERFACE AT INTERSECTION

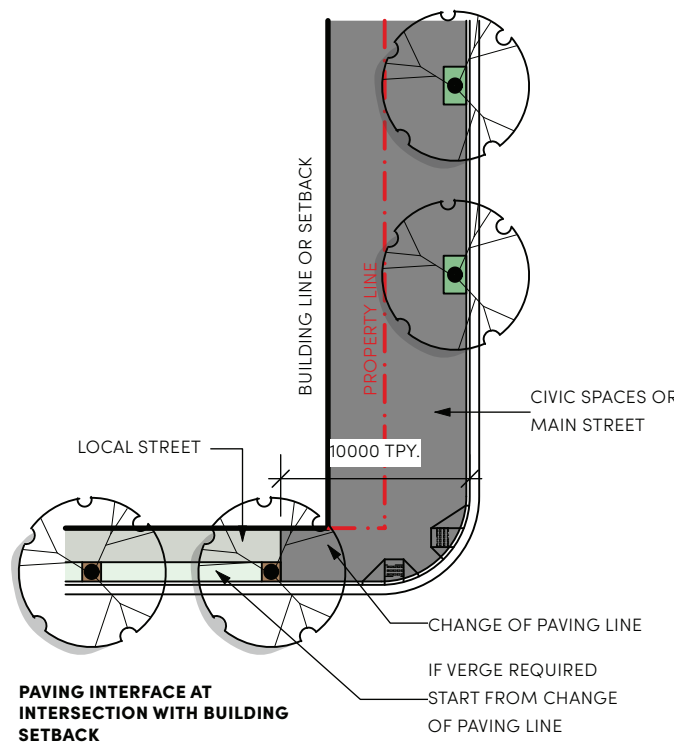

PAVING INTERFACE AT INTERSECTION WITH BUILDING SETBACK

3.1.6 Pavements and Levels Changes Details

Application

- Urban Area
- Where fully paved footpath changes direction

Product/ Material

- Pavements to Project Landscape Architects' specification.

Supplier

To be advised.

Construction Notes

- Provide single header course to building facade and along kerb line.
- All paving courses to be 90° to kerb unless other noted.
- Provide a mitred joint at the header course junction where paving direction changes.
- Saw-cut paver infills shall be no smaller than 30% of the full paver size.
- Width of joint to be between 3-10mm.
- Where pavers change direction at an intersection corner, minimise boundary effect of direction change as shown.

Paving Direction Change

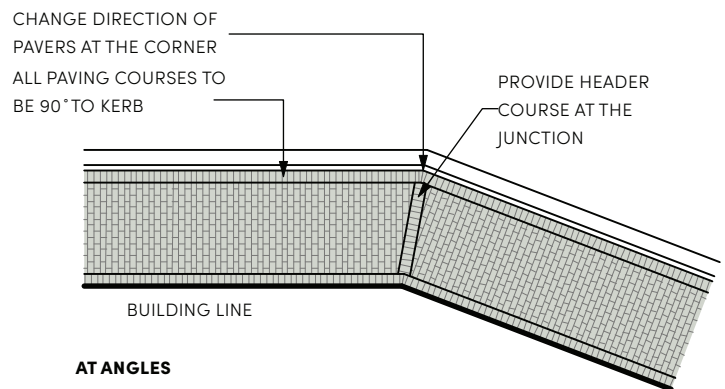

AT ANGLES

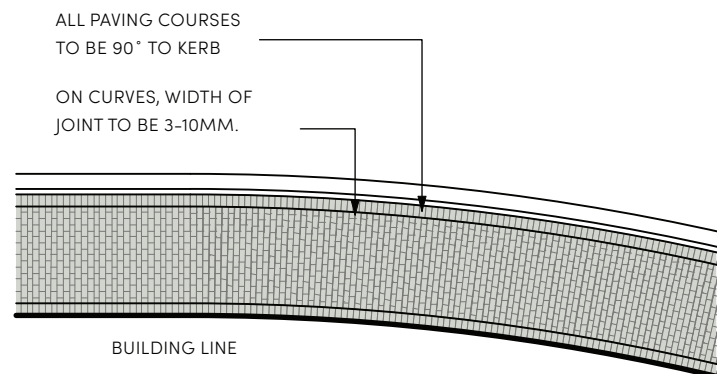

AT CURVES

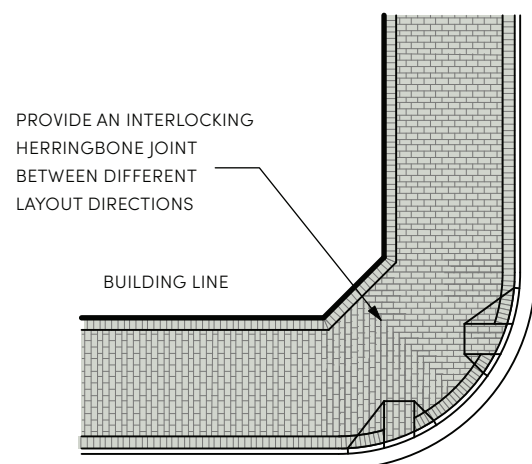

AT 90 DEGREE CORNERS

AT INTERSECTIONS WHERE SAME SIZE LARGE FORMAT UNIT PAVERS ARE USED ON BOTH INTERSECTING STREETS

3.1 Pavements and Levels Changes

3.1.6 Pavements and Levels Changes Guidelines

Application

- Urban Area (refer table 3.1.5)

Product/ Material

- Havenslab® 50
 - Size: 400x200x50mm
 - Colour Options: Charcoal

Supplier

Adbri Masonry

Address: Gateway Business Park, 63-79 Parramatta Road, Silverwater NSW 2128

Phone: 1300 365 565

Web: <https://www.adbrimasonry.com.au/home-professional/>

Construction Notes

- Installation to manufacturers instructions and engineers final specification.
- Reinforced concrete base slab to engineers final specification.
- Lay paving to required falls and levels.
- Pavers abutting fixed objects require 10mm sealant joints colour matched to surrounding paving.
- Cut pavers to neatly fit around all penetrations and fixtures including pit covers, poles, signs etc.
- Paving courses to be at 90 degrees to kerb unless otherwise noted.
- Set out of pavers is generally from kerb and cut to building line.
- Where paving borders follow a curved alignment, border pavers shall be laid to follow the curve, allowing 3-10mm maximum joint. If cutting is required, cut boarder pavers evenly.
- Saw-cut make-up units must not be less than 30% of original size.
- Where row trimming is required to maintain laying pattern, maximum trim is 50mm. If more than 1 row is trimmed, both trims to be equal.

Typical Large Format Pedestrian Paving



Sample - Havenslab 80 large format pavement

- Provide a header course at the interface between new and existing pavement.
- The paving must meet Australian Standards for slip resistance AS 4586-2013 - Slip resistance classification of new pedestrian surface materials.
- Refer Sydney Olympic Park Authority IECM Section 18 Pavement Base and Subbase for details.
- Refer Sydney Olympic Park Authority IECM Section 20 Paving for details.

Also refer to Sydney Olympic Park Authority's IECM:

N/A

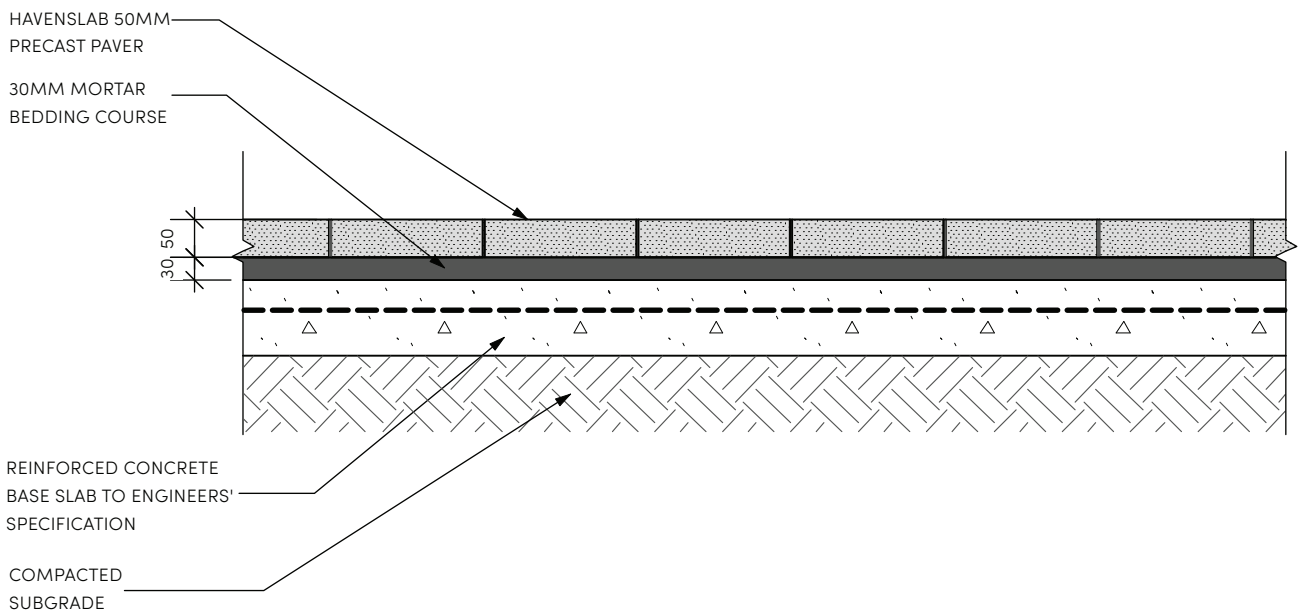

LARGE FORMAT PAVING 1:10

HAVENSLAB 50MM

SIZE: 400 X 200 X 50MM

COLOUR OPTIONS : CHARCOAL

3.1 Pavements and Levels Changes

3.1.6 Pavements and Levels Changes Guidelines

Application

- Urban Area (refer table 3.1.5)

Product/ Material

- Brickpave ® 80
 - Size: 230x115x80mm
 - Colour Options: Charcoal/ Oatmeal/ Natural

Supplier

Adbri Masonry

Address: Gateway Business Park, 63-79 Parramatta Road, Silverwater NSW 2128

Phone: 1300 365 565

Web: <https://www.adbrimasonry.com.au/home-professional/>

Construction Notes

- Installation to manufacturers instructions and engineers final specification.
- Recycled base material and reinforced concrete base slab to engineers final specification.
- Lay paving to required falls and levels.
- Pavers abutting fixed objects require 10mm sealant joints colour matched to surrounding paving.
- Cut pavers to neatly fit around all penetrations and fixtures including pit covers, poles, signs etc.
- Paving courses to be at 90 degrees to kerb unless otherwise noted.
- Set out of pavers is generally from kerb and cut to building line.
- Masonry pavers should be laid with a 3mm-10mm joint between the units. Joints 3mm-5mm in width shall be filled with a jointing sand such as Pavelock. For wider joints 5-10mm a non shrink grout be used.
- Where paving borders follow a curved alignment, border pavers shall be laid to follow the curve, allowing 3-10mm faceted joint. If cutting is required, cut border pavers evenly.
- Saw-cut make-up units must not be less than 30% of original size.

Typical Precast Pavers - Non Interlocking



Sample - Brickpave 80 non-interlocking pavement

- Provide a header course at the interface between new and existing pavement.
- Paving units must meet slip resistance category P5 as defined in AS 4586-2013 - Slip resistance classification of new pedestrian surface materials.
- Refer Sydney Olympic Park Authority IECM Section 18 Pavement Base and Subbase for details.
- Refer Sydney Olympic Park Authority IECM Section 20 Paving for details.

Also refer to Sydney Olympic Park Authority's IECM:

- P003
- K014

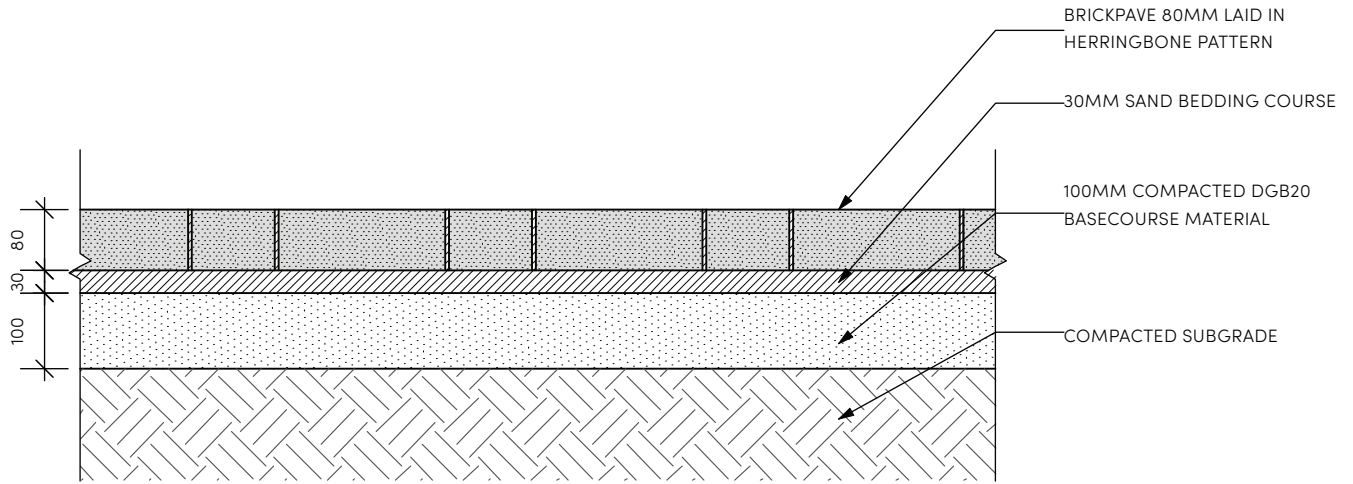

NON-INTERLOCKING PAVING - NON-TRAFFICABLE 1:10

BRICKPAVE 80MM

SIZE: 230X115X80MM

COLOUR OPTIONS: CHARCOAL / OATMEAL / NATURAL

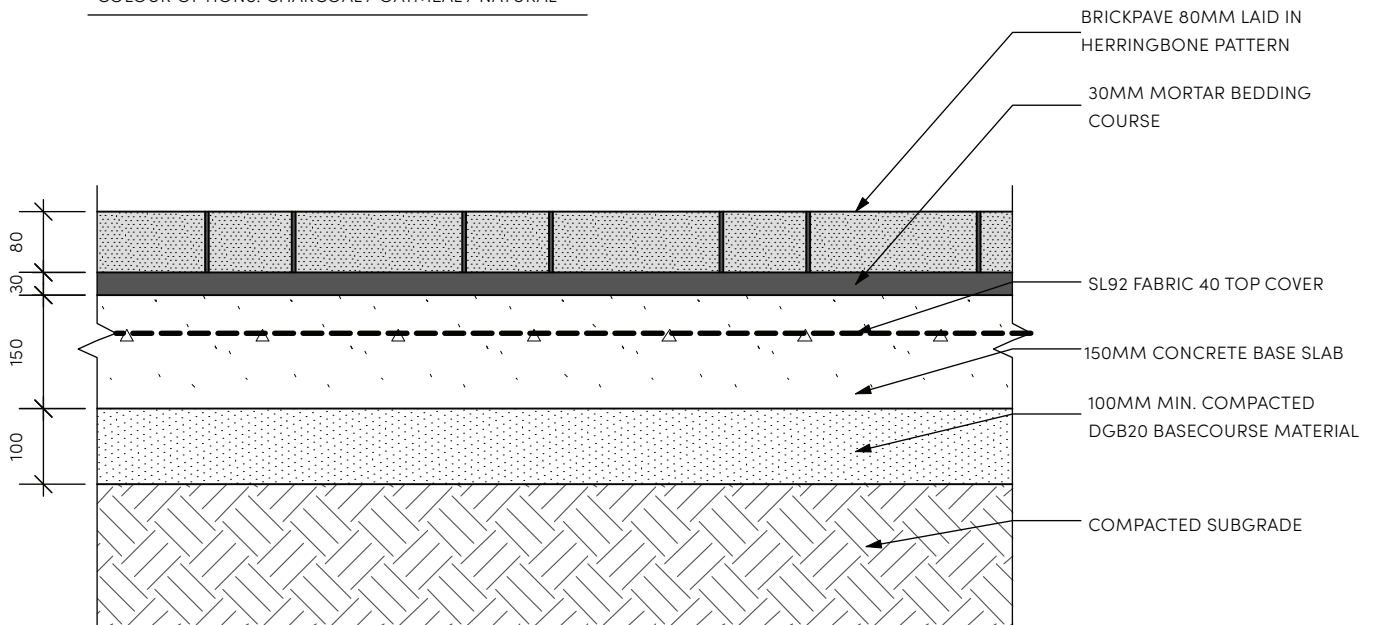

NON-INTERLOCKING PAVING - TRAFFICABLE 1:10

3.1 Pavements and Levels Changes

3.1.6 Pavements and Levels Changes Guidelines

Application

- Urban Area (refer table 3.1.5)

Product/ Material

- Trihex® 80
 - Size: 188x92x80mm
 - Colour Options: Charcoal/ Oatmeal/ Natural
- Unipave® 80
 - Size: 225x113x80mm
 - Colour Options: Charcoal/ Steel/ Portblend

Supplier

Adbri Masonry

Address: Gateway Business Park, 63-79 Parramatta Road, Silverwater NSW 2128

Phone: 1300 365 565

Web: <https://www.adbrimasonry.com.au/home-professional/>

Construction Notes

- Installation to manufacturers instructions and engineers final specification.
- Recycled base material to engineers final specification.
- Lay paving to required falls and levels.
- Pavers abutting fixed objects require 10mm sealant joints colour matched to surrounding paving.
- Cut pavers to neatly fit around all penetrations and fixtures including pit covers, poles, signs etc.
- Paving courses to be at 90 degrees to kerb unless otherwise noted.
- Set out of pavers is generally from kerb and cut to building line.
- Masonry pavers should be laid with a 3mm-10mm joint between the units. Joints 3mm-5mm in width shall be filled with a jointing sand such as Pavelock. For wider joints 5-10mm a non shrink grout be used.

Typical Precast Pavers - Interlocking



Sample - Trihex 80

Sample - Unipave 80

- Where paving borders follow a curved alignment, border pavers shall be laid to follow the curve, allowing 3-10mm faceted joint. If cutting is required, cut border pavers evenly.
- Saw-cut make-up units must not be less than 30% of original size.
- Provide a header course at the interface between new and existing pavement.
- Paving units must meet slip resistance category P5 as defined in AS 4586-2013 - Slip resistance classification of new pedestrian surface materials.
- Refer Sydney Olympic Park Authority IECM Section 18 Pavement Base and Subbase for details.
- Refer Sydney Olympic Park Authority IECM Section 20 Paving for details.

Also refer to Sydney Olympic Park Authority's IECM:

- P003

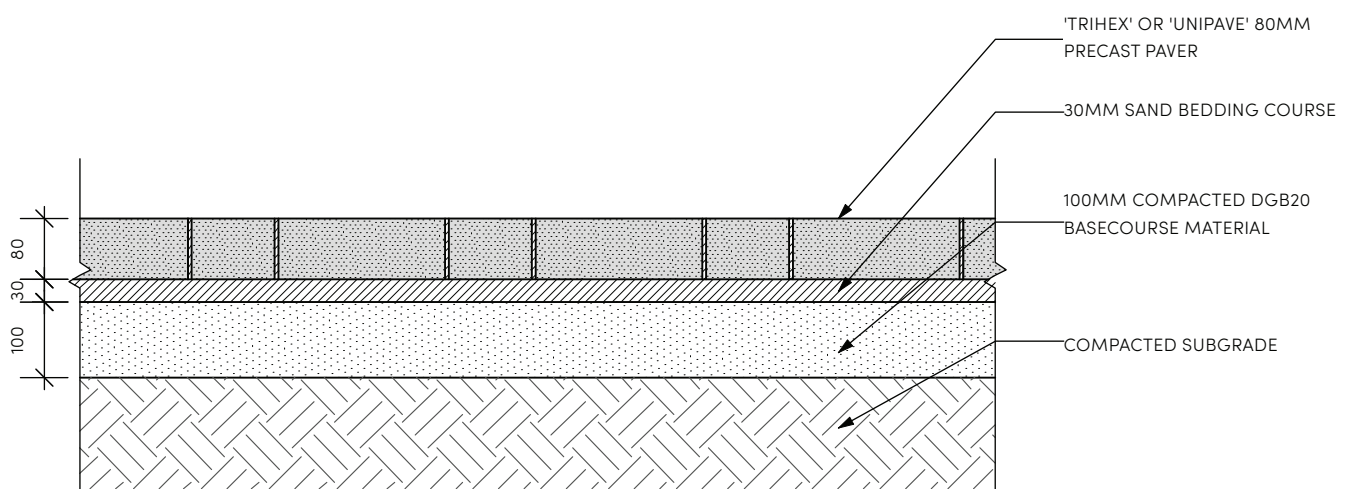

INTERLOCKING PAVING 1:10

TRIHEX 80MM

SIZE: 188X92X80MM

COLOUR OPTIONS: CHARCOAL / OATMEAL / NATURAL

UNIPAVE 80MM

SIZE: 225X113X80MM

COLOUR OPTIONS: CHARCOAL / STEEL / PORTBLEND

3.1 Pavements and Levels Changes

3.1.6 Pavements and Levels Changes Guidelines

Application

- Urban Area (refer table 3.1.5)

Product/ Material

- Havenslab® 50 (footpath)
 - Size: 400x200x50mm
 - Colour Options: Charcoal
- Brickpave® 80 (driveway crossing)
 - Size: 230x115x80mm
 - Colour Options: Charcoal/ Oatmeal/ Natural

Supplier

Adbri Masonry

Address: Gateway Business Park, 63-79 Parramatta Road, Silverwater NSW 2128

Phone: 1300 365 565

Web: <https://www.adbrimasonry.com.au/home-professional/>

Construction Notes

- Driveway paving to be laid on concrete base to engineers final specification.
- Bedding course and jointing to engineers final specification.
- Driveways to comply with AS/NZS 2890.1: 2004 Parking Facilities Part 1 – Off Street Parking.
- Refer Sydney Olympic Park Authority IECM Section 18 Pavement Base and Subbase for details.
- Refer Sydney Olympic Park Authority IECM Section 20 Paving for details.

Also refer to this manual:

- Section 3.1 PL03 for large format pedestrian paving
- Section 3.1 PL04 for non-interlocking precast pavers
- Section 3.5 EG08 for vehicle layback

Also refer to Sydney Olympic Park

Authority's IECM:

- K014

Typical Vehicle Crossover



Sample - Brickpave 80 non-interlocking pavement in herringbone pattern

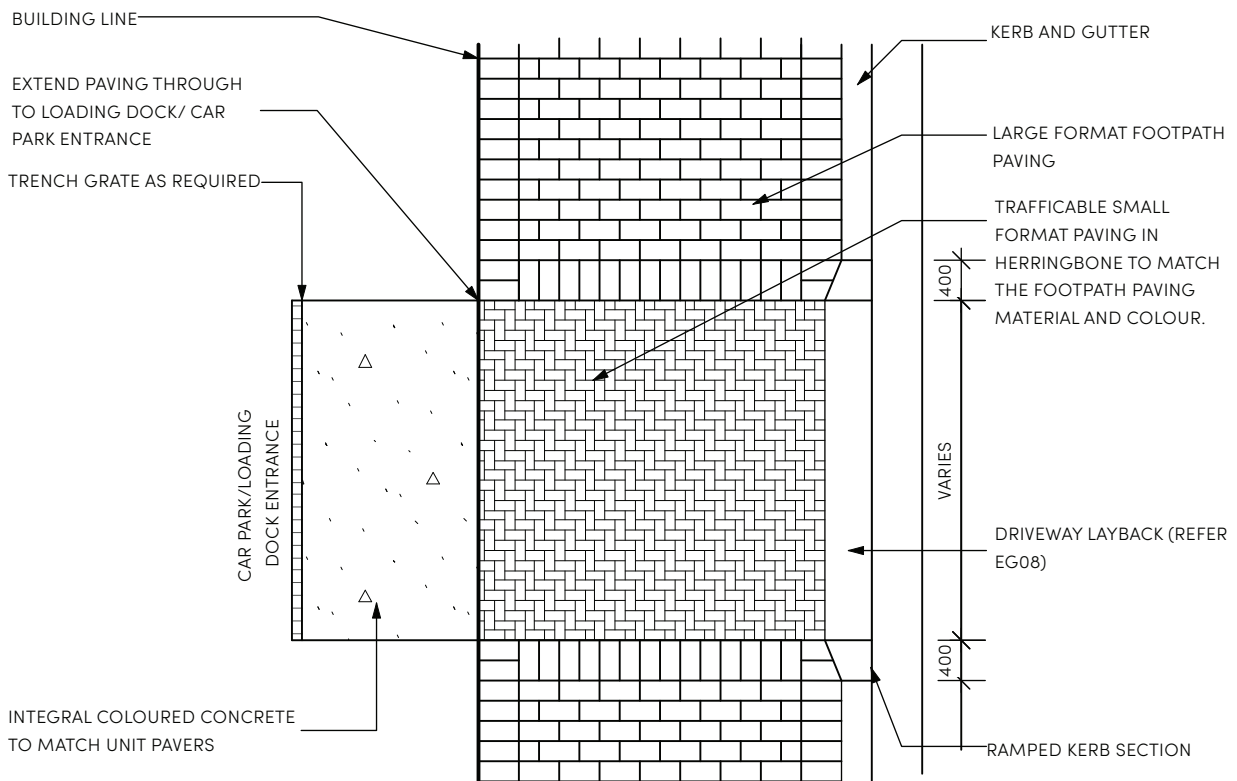

TYPICAL VEHICLE CROSSOVER 1:75

3.1 Pavements and Levels Changes

3.1.6 Pavements and Levels Changes Guidelines

Application

- Urban Area (refer table 3.1.5)

Product/ Material

- Honey Jasper
 - Size: pavers @ 600x300x50mm; cobblestones @ 95x95x50mm
 - Finish: Bush Hammered

Supplier

Sam the Paving Man

Address: Unit A, 61-65 Roberts Road Greenacre NSW
2190

Phone: +61 2 9642 5666

Web: <https://samthepavingman.com.au/>

Construction Notes

- Installation to manufacturers instructions and engineers final specification.
- Reinforced concrete base slab to engineers final specification.
- Lay paving to required falls and levels.
- Pavers abutting fixed objects require 10mm sealant joints colour matched to surrounding paving.
- Cut pavers to neatly fit around all penetrations and fixtures including pit covers, poles, signs etc.
- Paving courses to be at 90 degrees to kerb unless otherwise noted.
- Set out of pavers is generally from kerb and cut to building line.
- Stone slabs and stone setts should be laid with a 3mm-5mm joint between the units. Joints shall be a non shrink grout be used.
- Where paving borders follow a curved alignment, border pavers shall be laid to follow the curve, allowing 3-10mm faceted joint. If cutting is required, cut border pavers evenly.
- Saw-cut make-up units must not be less than 30% of original size.

Typical Granite Pavement



Sample - Honey Jasper granite pavement

- The paving must meet Australian Standards for slip resistance AS 4586-2013 - Slip resistance classification of new pedestrian surface materials.
- Refer Sydney Olympic Park Authority IECM Section 18 Pavement Base and Subbase for details.
- Refer Sydney Olympic Park Authority IECM Section 20 Paving for details.

Also refer to Sydney Olympic Park Authority's IECM:

N/A

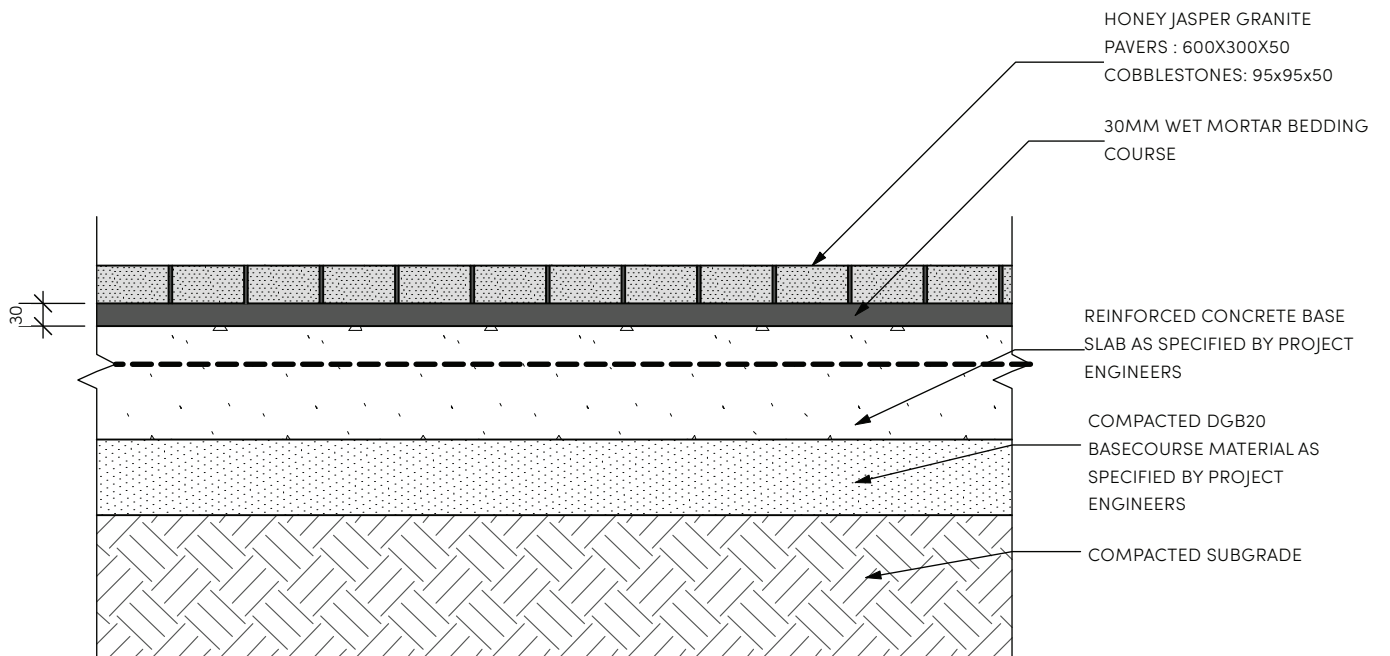

GRANITE SETT PAVING - TRAFFICABLE 1:10

3.1 Pavements and Levels Changes

3.1.6 Pavements and Levels Changes Guidelines

Application

- Urban Area (refer table 3.1.5)
- To be used in conjunction with 80mm Trihex pavers, adjacent to tree planting with tree grate, and structural soil or structural soil cells beneath.

Product/ Material

- Ecotrihex® 80
 - Size: 188x92x80mm
 - Colour Options: Charcoal/ Natural

Supplier

Adbri Masonry

Address: Gateway Business Park, 63-79 Parramatta Road, Silverwater NSW 2128

Phone: 1300 365 565

Web: <https://www.adbrimasonry.com.au/home-professional/>

Construction Notes

- Installation to manufacturers instructions and engineers final specification.
- Lay paving to required falls and levels.
- Pavers abutting fixed objects require 10mm sealant joints colour matched to surrounding paving.
- Cut pavers to neatly fit around all penetrations and fixtures including pit covers, poles, signs etc.
- Paving courses to be at 90 degrees to kerb unless otherwise noted.
- Set out of pavers is generally from kerb and cut to building line.
- Saw-cut make-up units must not be less than 30% of original size.
- Provide a header course at the interface between new and existing pavement.
- Paving units must meet slip resistance category P5 as defined in AS 4586-2013 - Slip resistance classification of new pedestrian surface materials.
- Refer Sydney Olympic Park Authority IECM Section 18 Pavement Base and Subbase for details.

Typical Permeable Pavement



Sample - Ecotrihex 80 permeable pavement

- Refer Sydney Olympic Park Authority IECM Section 20 Paving for details.

Also refer to Sydney Olympic Park

Authority's IECM:

N/A

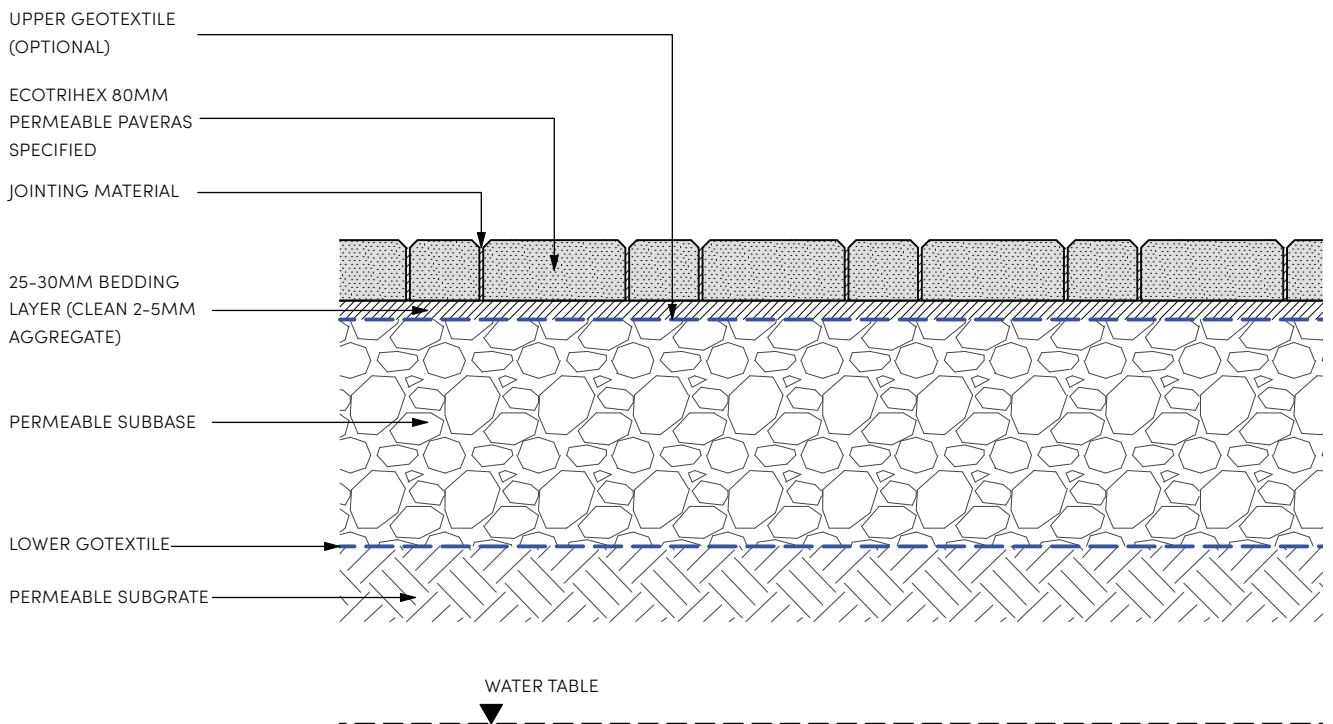

TYPICAL PERMEABLE PAVING 1:10

ECOTRIHEX 80MM

SIZE: 188X92X80MM

COLOUR OPTIONS: CHARCOAL / NATURAL

3.1 Pavements and Levels Changes

3.1.6 Pavements and Levels Changes Guidelines

Application

- Urban Area (refer table 3.1.5)
- Parklands (refer table 3.1.5)

Product/ Material

- Concrete Broom finish, or
- Concrete exposed aggregate finish
 - Standard: To AS 2758.1
 - 'Kembla' 10-20mm dia aggregate
 - White cement

Supplier

Aggregate:

HOLCIM Australia

Address: 161 East West Link Croom NSW 2527

Phone: 1300 555 277

Web: <https://www.holcim.com.au/>

Construction Notes

- Refer Sydney Olympic Park Authority IECM Section 19 Concrete Pavement for details.
- Concrete surface must meet slip resistance category P5 as defined in AS 4586-2013 - Slip resistance classification of new pedestrian surface materials.
- All concrete formed surface shall be in accordance with AS 3610.
- Provide 5mm round edge to all sides.

Also refer to Sydney Olympic Park

Authority's IECM:

- P002
- K014

Typical Concrete Pavement



Sample -Concrete pavement (exposed aggregate finish (left) and broom finish (right))

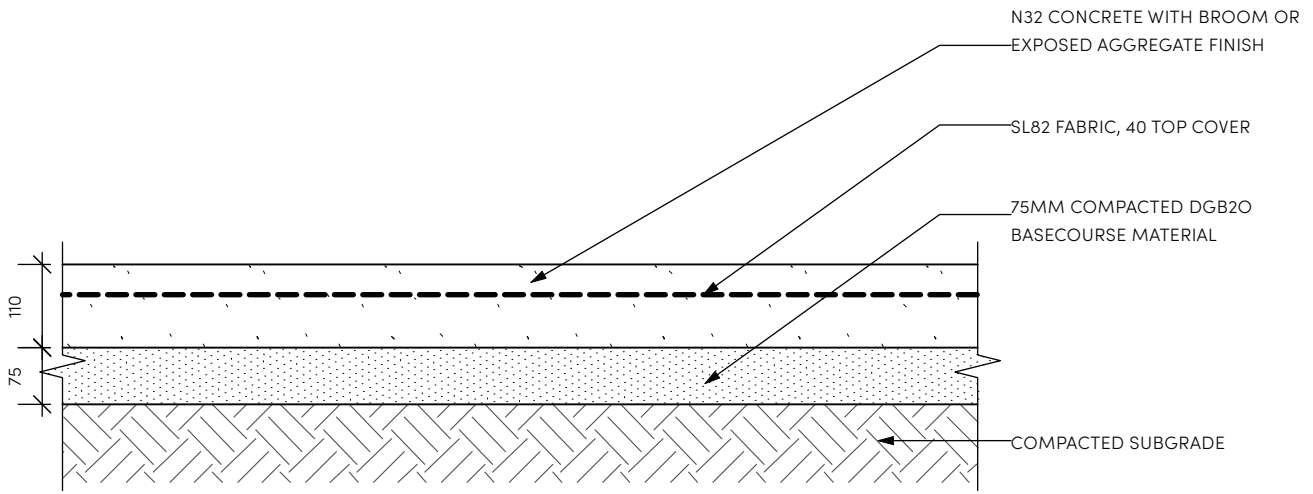

CONCRETE PAVEMENT - NON-TRAFFICABLE 1:10

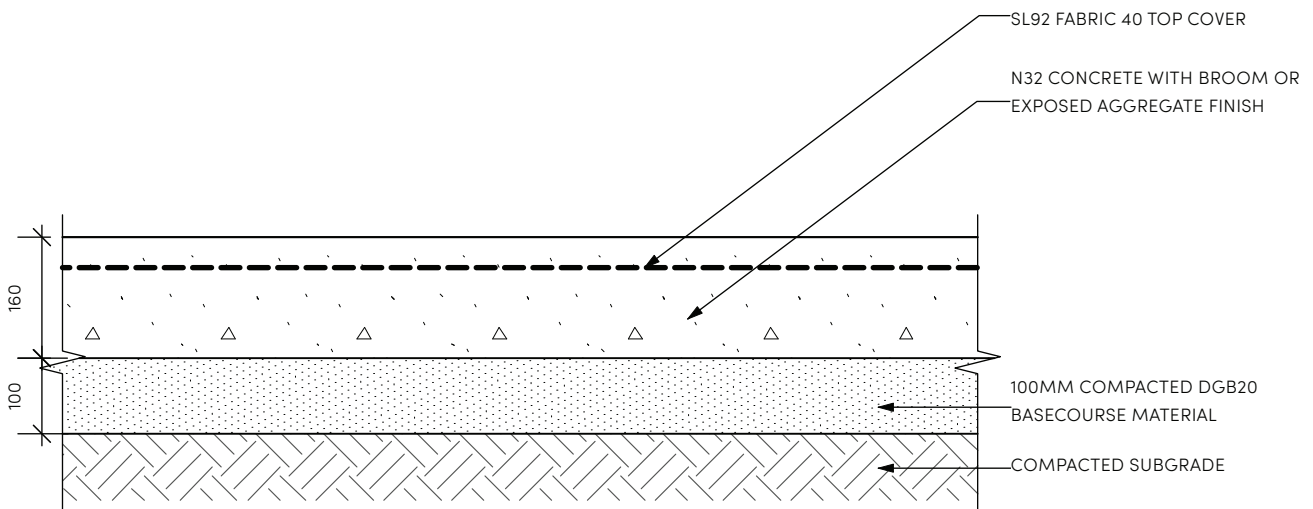

CONCRETE PAVEMENT - TRAFFICABLE 1:10

3.1 Pavements and Levels Changes

3.1.6 Pavements and Levels Changes Guidelines

Application

- **Asphaltic Concrete General**
 - Urban Area (refer table 3.1.5)
 - Parklands (refer table 3.1.5)
- **Asphaltic Concrete Special**
 - As advised by the Authority (refer table 3.1.5)
- Trafficable asphaltic concrete pavement with concrete subbase is applied to driveways only.

Product/ Material

- 30mm depth AC 10 wearing course.
- Composition
 - **General:** Standard mix with standard gravel (blue metal) to engineers final detail.
 - **Special:** Standard mix with white ryolite gravel or similar to engineers final detail.
 - **Olympic Plaza:** Red oxide

Supplier

As approved by the Authority

Construction Notes

- Primer seal below wearing course.
- Recycled base material to engineers final specification.

Maintenance and Repairs

- Surface repairs to replace full width of pavement to nearest joint or minimum 3m length to avoid patchiness.
- Saw cut edges to adjacent pavement for reinstatement.

Also refer to Sydney Olympic Park

Authority's IECM:

- P001
- K014

Typical Asphaltic Concrete Pavement



Sample - Asphaltic concrete pavement

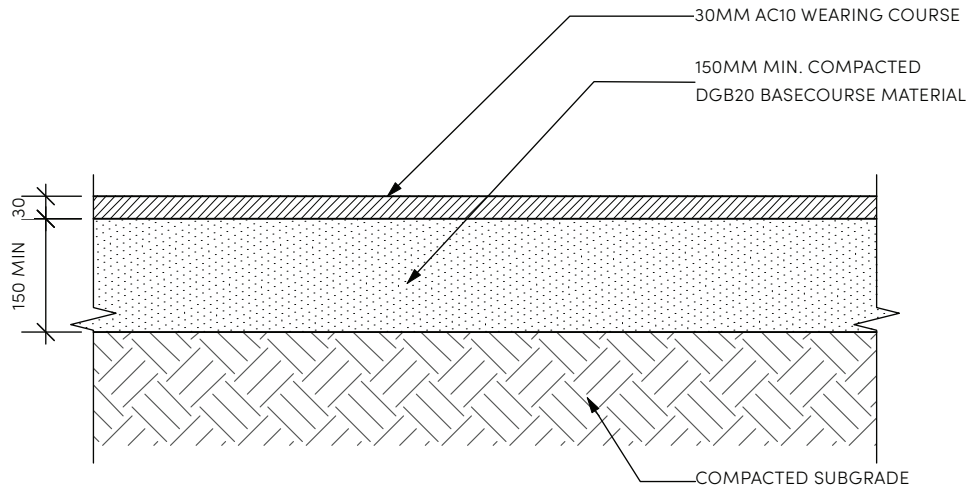

ASPHALT PAVEMENT - NON-TRAFFICABLE 1:10

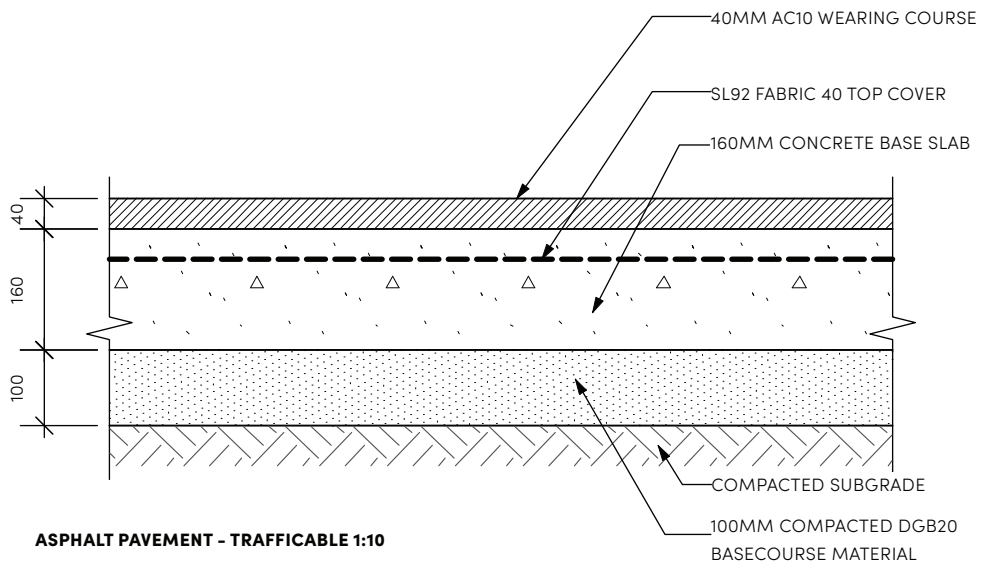

ASPHALT PAVEMENT - TRAFFICABLE 1:10

3.1 Pavements and Levels Changes

3.1.6 Pavements and Levels Changes Guidelines

Application

- Urban Area and Parklands
- At intersections (local Streets) , crossing points (local streets), bus zones, accessible drop off points and taxi stands.

Product/ Material

- Kerb ramp in surrounding pavement material on reinforced concrete base as shown or concrete kerb ramp.
- Tactile ground surface indicators refer Section 3.1 PL16.

Supplier

As approved by the Authority

Construction Notes

- To engineers final specification.
- Recycled base material to Engineers' final specification.
- Align kerb ramp with line of travel and with building line if possible. Kerb ramps on opposite sides should align with each other.
- Provide upper landings that are 1:40 crossfall max., preferably minimum 1.5m x 1.5m.
- All concrete formed surface shall be in accordance with AS 3610.
- For paved pram ramp, saw-cut make-up units must not be less than 30% of original size.
- Pavement finish must meet slip resistance category P5 as defined in AS 4586-2013 - Slip resistance classification of new pedestrian surface materials.

Also refer to this manual:

- Section 3.1 PL17 for tactile ground surface indicators

Also refer to Sydney Olympic Park

Authority's IECM:

- K012

Typical Kerb Ramp - Small



Sample - Standard kerb ramp

3.1 Pavements and Levels Changes

3.1.6 Pavements and Levels Changes Guidelines

Application

- Urban Area and Parklands
- At intersections (Civic Spaces and Main Streets) and crossing points (Civic Spaces and Main Streets)

Product/ Material

- Kerb ramp in surrounding pavement material on reinforced concrete base as shown or concrete kerb ramp.
- Tactile ground surface indicators refer Section 3.1 PL16.

Supplier

As approved by the Authority

Construction Notes

- To engineers final specification.
- Recycled base material to Engineers' final specification.
- Align kerb ramp with line of travel and with building line if possible. Kerb ramps on opposite sides should align with each other.
- Provide upper landings that are 1:40 crossfall max., preferably minimum 1.5m x 1.5m
- All concrete formed surface shall be in accordance with AS 3610.
- For paved pram ramp, saw-cut make-up units must not be less than 30% of original size.
- Pavement finish must meet slip resistance category P5 as defined in AS 4586-2013 - Slip resistance classification of new pedestrian surface materials.

Also refer to this manual:

- Section 3.1 PL17 for tactile ground surface indicators

Also refer to Sydney Olympic Park

Authority's IECM:

- K011

Typical Kerb Ramp - Large



Sample - Large kerb ramp

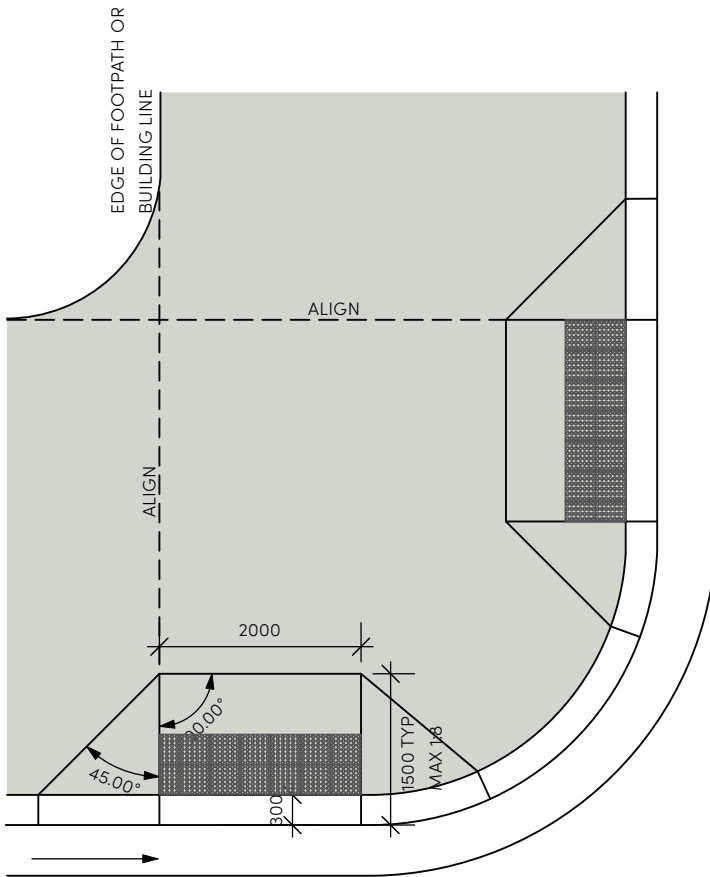

OR 45°

OR 45°

PLAN 1:75

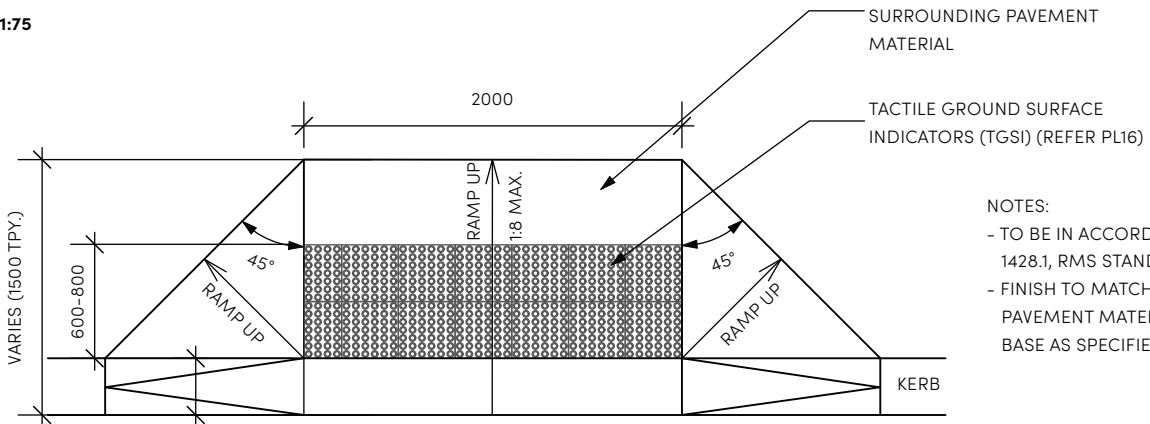

PLAN 1:40

K&G1= 300±10
K&G2= 150±10

NOTES:

- TO BE IN ACCORDANCE WITH AS 1428.1, RMS STANDARDS
- FINISH TO MATCH SURROUNDING PAVEMENT MATERIAL ON CONCRETE BASE AS SPECIFIED

ELEVATION 1:40

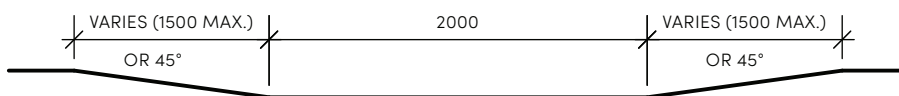

3.1 Pavements and Levels Changes

3.1.6 Pavements and Levels Changes Guidelines

Application

- Urban Area
- A stair shall be applied wherever there is a need to provide safe and accessible vertical circulation between different levels of a site.

Product/ Material

- Pavers- Havenslab® 50
 - Size: 400x200x50mm
 - Colour Options: Charcoal
- Tactile ground surface indicators refer Section 3.1.6 PL17
- Step Nosing (ACS-50 Safety Insert Tread stainless steel profile with "Supagrit" silicon carbide mineral infill)
 - Size: 50mmW x 10mmH
 - Colour: Off White
- Handrail refer Section 3.2.4 F25 and F26

Supplier

Pavers

Adbri Masonry

Address: Gateway Business Park, 63-79 Parramatta Road, Silverwater NSW 2128

Phone: 1300 365 565

Web: <https://www.adbrimasonry.com.au/home-professional/>

Step Nosing

Latham Australia

Address: 14 Tennyson Road Gladesville NSW 2111

Phone: 02 9879 7888

Web: <https://www.latham-australia.com/>

Construction Notes

- Stair must conform with Building Code of Australia, AS 1428 and Sydney Olympic Park Authority Access Guidelines.
- Installation to engineers final specification.

Typical Paved Steps



Sample - Paved steps

- Stairs to be certified by an access consultant.
- Top step to be horizontal. Avoid sloping top steps where practical.
- Pavement finish must meet slip resistance category P5 as defined in AS 4586-2013 - Slip resistance classification of new pedestrian surface materials.
- Non-slip insert nosing to treads to comply with AS 1428 and Sydney Olympic Park Authority Access Guidelines. Nosing to be rebated into pavers.

Also refer to this manual:

- Section 3.1 PL16 for tactile ground surface indicators
- Section 3.2 F25 for handrail - wall mounted
- Section 3.2 F26 for handrail - free standing

Also refer to Sydney Olympic Park Authority's IECM:

- P013

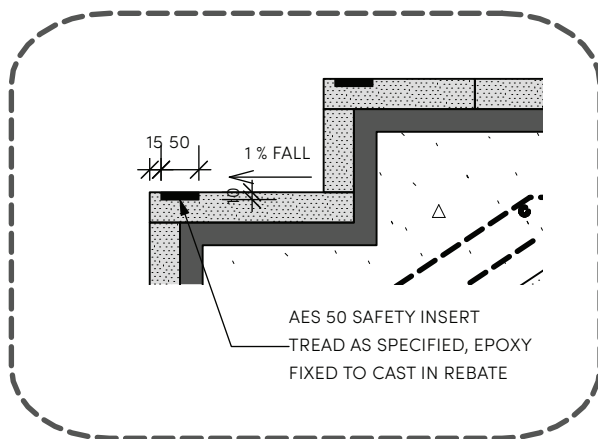
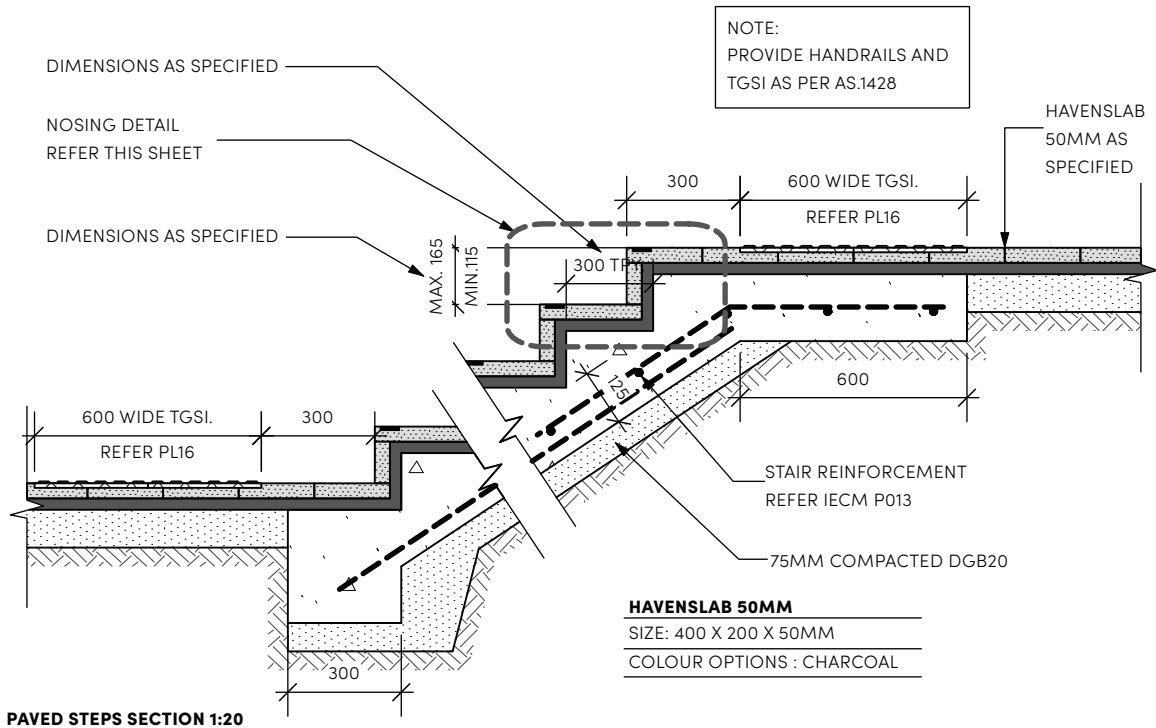

3.1 Pavements and Levels Changes

3.1.6 Pavements and Levels Changes Guidelines

Application

- Urban Area and Parklands
- A stair shall be applied wherever there is a need to provide safe and accessible vertical circulation between different levels of a site.

Product/ Material

- Concrete
 - In situ concrete stair
 - Colour - off white (colour sample to be approved by Sydney Olympic Park Authority)
 - Step risers shall be Class 2 off form concrete
- Tactile ground surface indicators refer Section 3.1.6 PL16
- Step Nosing (ACS-50 Safety Insert Tread stainless steel profile with "Supagrit" silicon carbide mineral infill)
 - Size: 50mmW x 10mmH
 - Colour: Black
- Handrail refer Section 3.2.4 F25 and F26

Supplier

Step Nosing

Latham Australia

Address: 14 Tennyson Road Gladesville NSW 2111

Phone: 02 9879 7888

Web: <https://www.latham-australia.com/>

Construction Notes

- Stair must conform with Building Code of Australia, AS 1428 and Sydney Olympic Park Authority Access Guidelines.
- Installation to engineers final specification.
- Stairs to be certified by an access consultant.
- Top step to be horizontal. Avoid sloping top steps where practical.
- All concrete formed surface shall be in accordance with AS 3610.
- Pavement finish must meet slip resistance category P5 as defined in AS 4586-2013 - Slip resistance

Typical Concrete Steps



Sample - Concrete steps

classification of new pedestrian surface materials..

- Non-slip insert nosing to treads to comply with AS 1428 and Sydney Olympic Park Authority Access Guidelines. Nosing to be rebated into concrete.

Also refer to this manual:

- Section 3.1 PL16 for tactile ground surface indicators
- Section 3.2 F25 for handrail - wall mounted
- Section 3.2 F26 for handrail - free standing

Also refer to Sydney Olympic Park Authority's IECM:

- P012

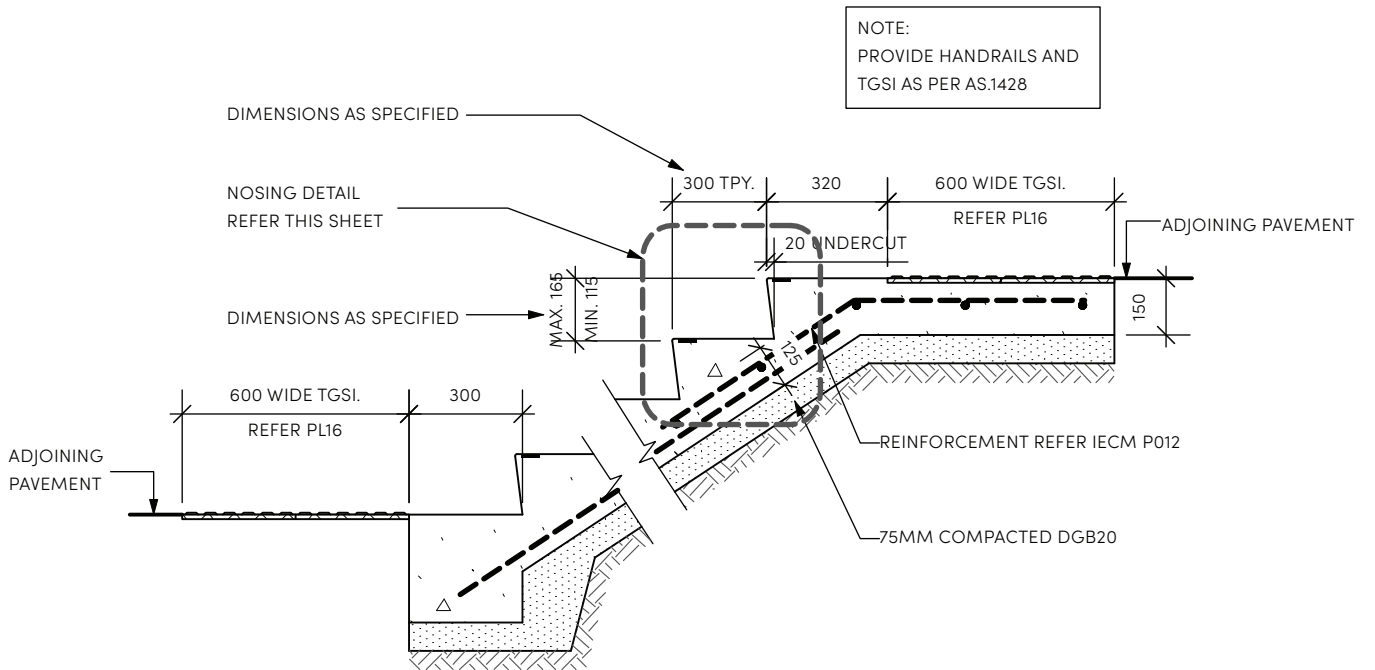

CONCRETE STEPS SECTION 1:20

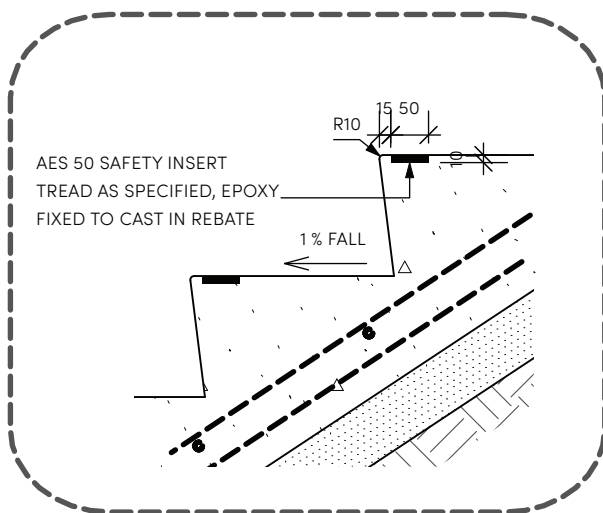

NOSING DETAIL 1:10

3.1 Pavements and Levels Changes

3.1.6 Pavements and Levels Changes Guidelines

Application

- Urban Area and Parklands
- An accessible ramp shall be applied wherever a continuous accessible path of travel is required between different levels of a site.

Product/ Material

- Ramp finish to match adjacent paving material.
- Tactile ground surface indicators refer Section 3.1.6 PL17.
- Ramp gradient shall not exceed 1:14.
- Provide handrails and supporting facilities in accordance with AS 1428 Design for access and mobility.
- Handrail refer Section 3.2.4 F25 and F26.

Supplier

As approved by the Authority

Construction Notes

- Where practical use a walkway (gradient <1:20) so that handrails can be avoided.
- Ramp must conform with AS 1428 and Sydney Olympic Park Authority Access Guidelines.
- Installation to engineers final specification.
- All concrete formed surface shall be in accordance with AS 3610.
- The concrete surface must meet Australian Standards for slip resistance AS 4586-2013 - Slip resistance classification of new pedestrian surface materials.

Also refer to this manual:

- Section 3.1 PL16 for tactile ground surface indicators
- Section 3.2 F25 for handrail - wall mounted
- Section 3.2 F26 for handrail - free standing

Also refer to Sydney Olympic Park

Authority's IECM:

N/A

Typical Ramp



Sample - Ramp

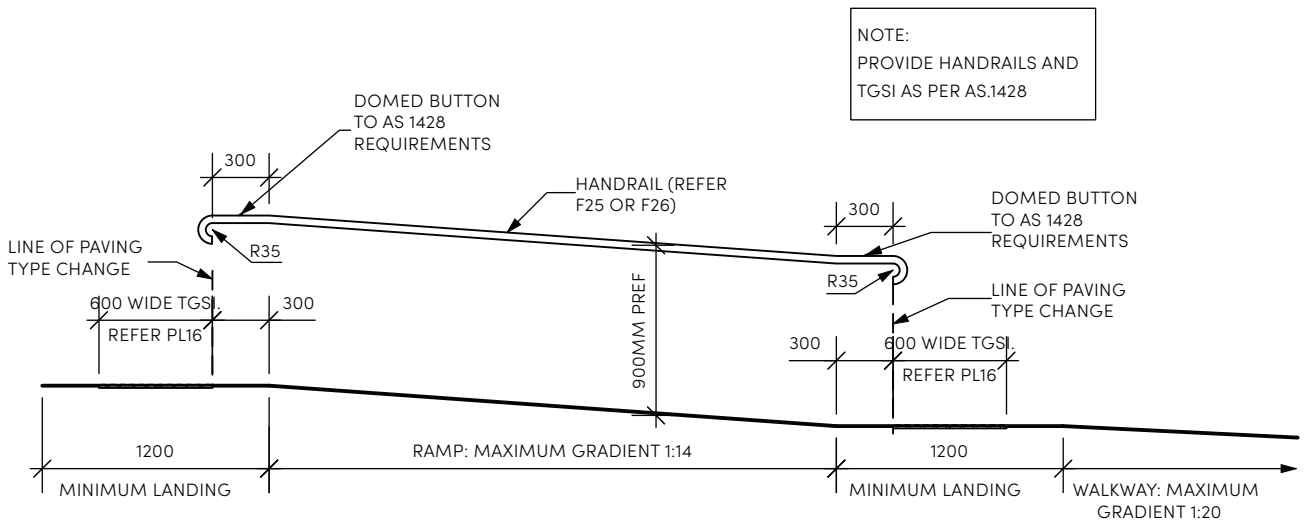

TYPICAL RAMP 1:40

3.1 Pavements and Levels Changes

3.1.6 Pavements and Levels Changes Guidelines

Application

- Urban Areas and Parklands
- Warning TGSIs indicate an approaching hazard, such as top and bottom of stairs and ramps, kerb ramps and raised crossings.

Product/ Material

- Classic Tredfx CH40 ceramic warning tile
 - Size: 300x300x10mm
 - Colour Options: Charcoal/ IvoryNote: Luminance contrast to comply with AS 1428.4 requirements. If required luminance contrast cannot be achieved using nominated product seek direction from Sydney Olympic Park Authority before proceeding.

Supplier

Classic Architectural Group

Address: Unit 6, 29-33 Amax Avenue Girraween NSW
2145

Phone: 1300 244 377

Web: <https://classic-arch.com>

Construction Notes

- Installation to manufacturer's recommendations.
- Arrangement to comply with AS 1428 requirements.
- Tactile ground surface indicators to comply with AS 1428.4.1 requirements.

Also refer to Sydney Olympic Park

Authority's IECM:

N/A

Hazard Warning Tactile Ground Surface Indicators



Sample - Ceramic warning tactile ground surface indicators

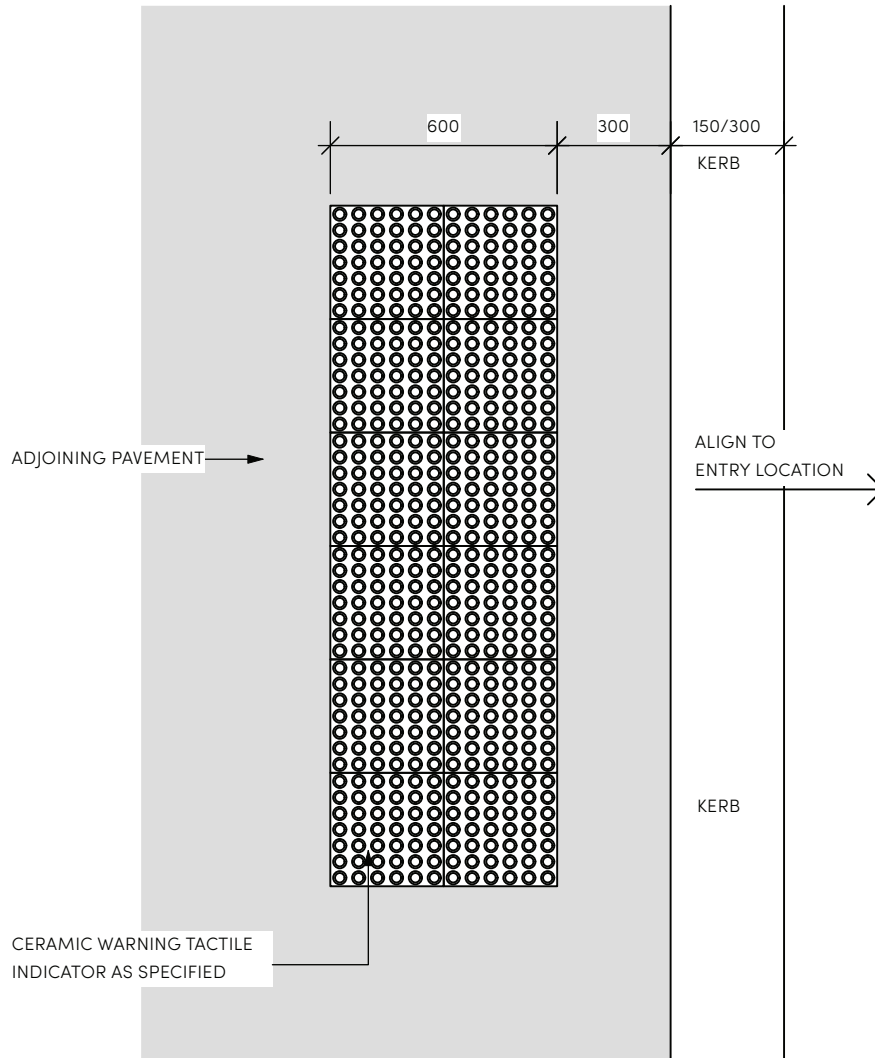

TACTILE PLAN 1:20

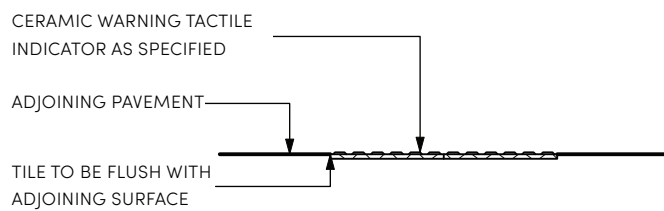

TACTILE SECTION 1:20

3.1 Pavements and Levels Changes

3.1.6 Pavements and Levels Changes Guidelines

Application

- Urban Areas and Parklands
- Directional TGSIs are provided to give directional orientation in open spaces where there are insufficient tactile directional cues, typically to bus stops.

Product/ Material

- Classic Tredfx CD49 ceramic directional tile
 - Size: 300x300x10mm
 - Colour Options: Charcoal/ IvoryNote: Luminance contrast to comply with AS 1428.4 requirements. If required luminance contrast cannot be achieved using nominated product seek direction from Sydney Olympic Park Authority before proceeding.

Supplier

Classic Architectural Group

Address: Unit 6, 29-33 Amax Avenue Girraween NSW
2145

Phone: 1300 244 377

Web: <https://classic-arch.com>

Construction Notes

- Installation to manufacturer's recommendations.
- Arrangement to comply with AS 1428 requirements.
- Tactile ground surface indicators to comply with AS 1428.4.1 requirements.

Also refer to Sydney Olympic Park

Authority's IECM:

N/A

Directional Tactile Ground Surface Indicators

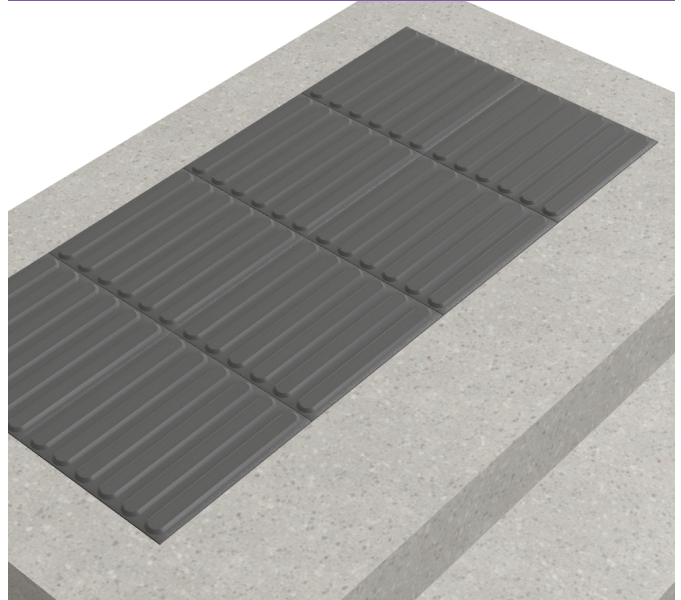

Sample - Ceramic directional tactile ground surface indicators

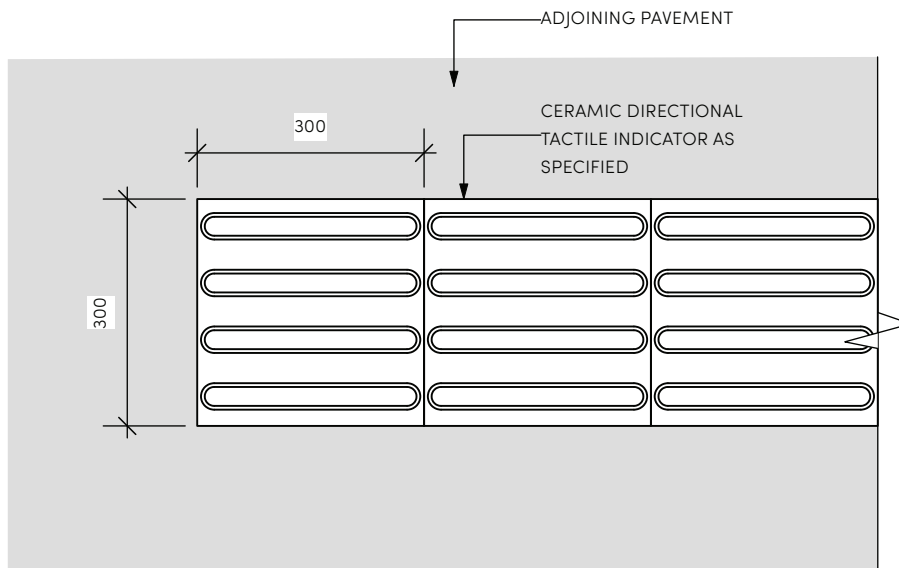

DIRECTIONAL TACTILE PLAN 1:10

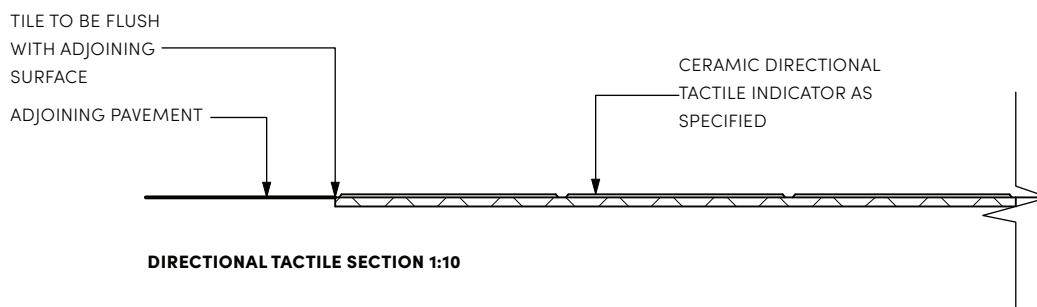

DIRECTIONAL TACTILE SECTION 1:10

3.1 Pavements and Levels Changes

3.1.6 Pavements and Levels Changes Guidelines

Application

- Urban Areas
- Minimise the visual impact of service covers in pavements by using infill paving covers that matches the surrounding surface, and by reducing or avoiding concrete surrounds to covers.

Product/ Material

- Pit lid product as specified by landscape architect;
- To footpath (including driveway access) and shared zone, infill pit lid to be Class C maximum, and
- To carriageway, infill pit lid to be Class D.

Supplier

As approved by the Authority

Construction Notes

- Concrete surround to be set down below pavement surface.
- Cover to be lockable.
- Metal pits only to be used.
- Openings to comply with AS 1428.
- Liaise with service authorities for service pit lid requirements.
- Pit lids frames and grate covers are to be flush with the surrounding surface.
- Cut and infill pavers to match the surrounding pavement type and pattern.

Also refer to Sydney Olympic Park

Authority's IECM:

- SW005

Typical Infill Pit Lid - Single Part



Sample - Single part infill pit lid

REALIGN NEW PIT COVER TO MATCH NEW PAVING PATTERN (BY INCREASING PIT LID SIZE). MAXIMUM REALIGNMENT TO BE 10 DEG. OBTAIN APPROVAL FROM AUTHORITY FOR COVER REALIGNMENT

75 DIA. STAINLESS STEEL DISK EPOXY FIXED TO PAVERS. ENGRAVE SYMBOL SURFACE TO DETAIL

10 SEALANT JOINT WITH BACKING ROD TO PERIMETER OF METAL FRAME
COLOUR : DARK GREY TO BE APPROVED BY SUPERINTENDENT

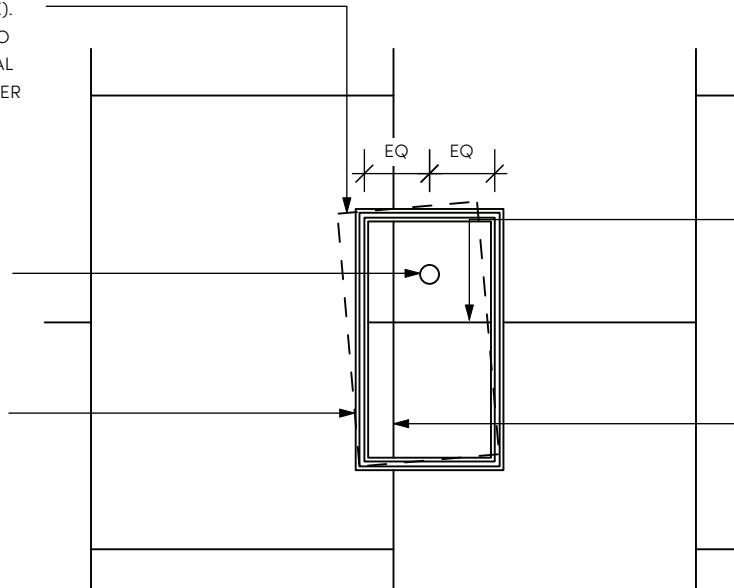

NOTE:

- PAVING INSERTS TO BE FLUSH WITH AND MATCH ADJACENT PAVIN SURROUNDS
- CONTINUE PAVERS JOINTS ACROSS THE COVER REGARDLESS OF ITS ORIENTATION

CUT PAVERS TO FIT INTO METAL PIT LID TO CONTINUE PATTERN OF SURROUNDING PAVING. LOCATION OF PIT COVER IN RELATION TO PAVING PATTERN VARIES

CONTINUE JOINTS ACROSS THE COVER REGARDLESS OF ITS ORIENTATION

DUMMY CUT INFILL PAVERS AT EDGES OF LID TO AVOID DISLODGEEMENT OF SMALL PIECES (MAX 3mm WIDE X 3mm DEEP CUT)

SINGLE PIT LID PLAN 1:10

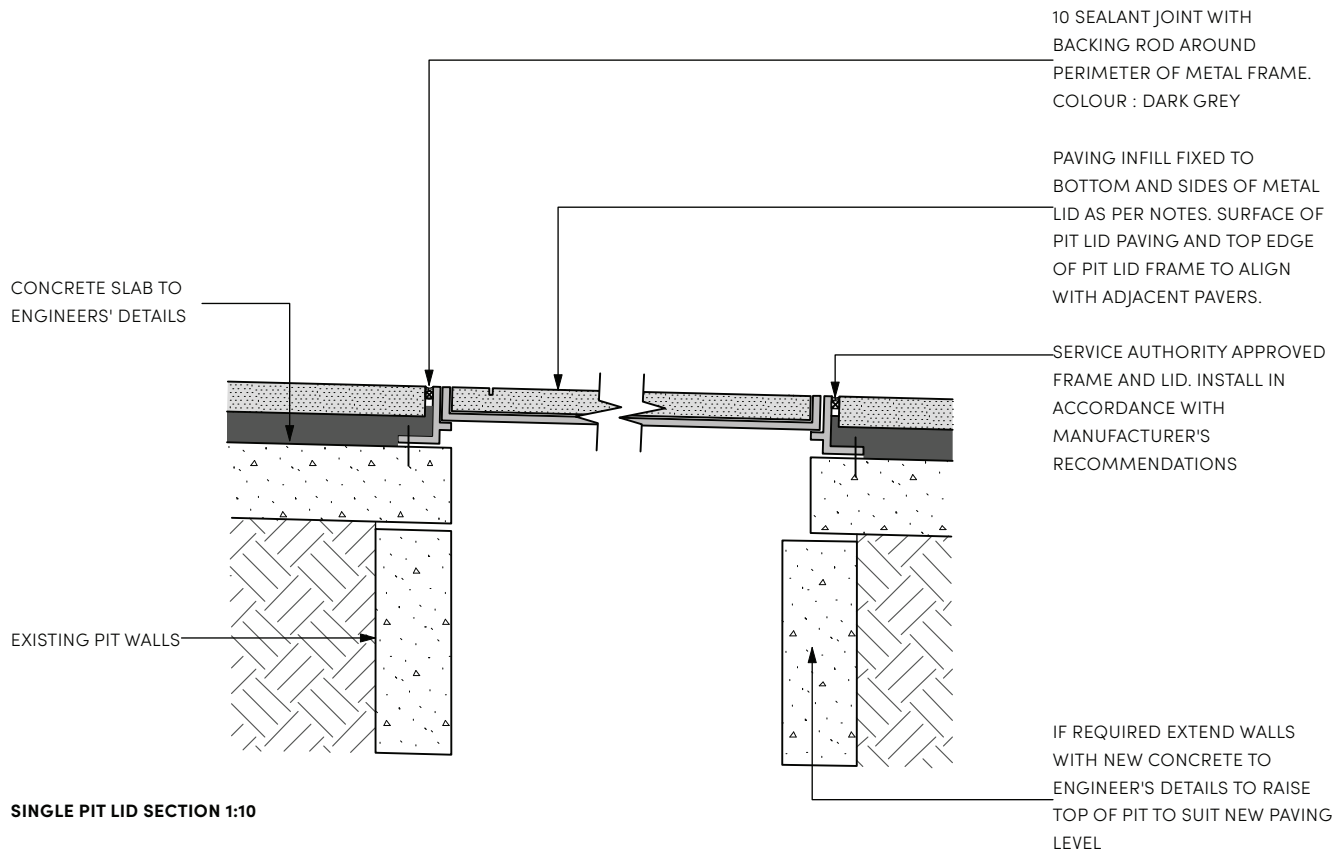

CONCRETE SLAB TO ENGINEERS' DETAILS

EXISTING PIT WALLS

10 SEALANT JOINT WITH BACKING ROD AROUND PERIMETER OF METAL FRAME. COLOUR : DARK GREY

PAVING INFILL FIXED TO BOTTOM AND SIDES OF METAL LID AS PER NOTES. SURFACE OF PIT LID PAVING AND TOP EDGE OF PIT LID FRAME TO ALIGN WITH ADJACENT PAVERS.

SERVICE AUTHORITY APPROVED FRAME AND LID. INSTALL IN ACCORDANCE WITH MANUFACTURER'S RECOMMENDATIONS

IF REQUIRED EXTEND WALLS WITH NEW CONCRETE TO ENGINEER'S DETAILS TO RAISE TOP OF PIT TO SUIT NEW PAVING LEVEL

SINGLE PIT LID SECTION 1:10

3.1 Pavements and Levels Changes

3.1.6 Pavements and Levels Changes Guidelines

Application

- Urban Area and Parklands
- For 2-part pit lids, use infill paving covers that match the surrounding surface to minimise the visual impact of service covers in pavements. And reduce or avoid concrete surrounds to covers.
- For multi-part pit lids (more than 2 parts), use ductile iron covers. And reduce or avoid concrete surrounds to covers.

Product/ Material

- Pit lid product as specified by landscape architect;
- To footpath (including driveway access) and shared zone, pit lid to be Class C maximum;
- To carriageway, pit lid to be Class D;
- For 2-part pit lids, use infill paving covers that match the surrounding surface, and
- For multi-part pit lids (more than 2 parts), use ductile iron covers.

Supplier

As approved by the Authority

Construction Notes

- Concrete surround to be set down below pavement surface.
- Cover to be lockable.
- Metal pits only to be used.
- Openings to comply with AS 1428.
- Liaise with service authorities for service pit lid requirements.
- Pit lids frames and grate covers are to be flush with the surrounding surface.
- Cut and infill pavers to match the surrounding pavement type and pattern.

Typical Pit Lid - Multi Parts

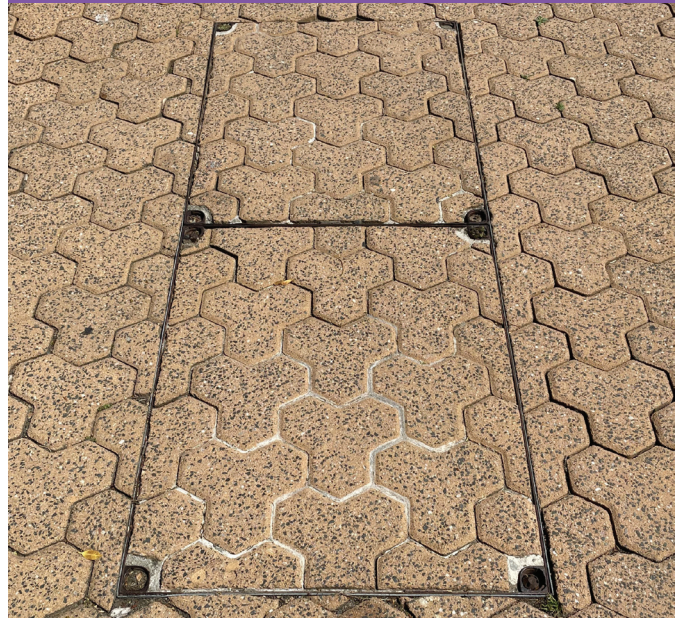

Sample - 2 parts infill pit lid

Also refer to Sydney Olympic Park Authority's IECM:

- SW004
- SW005

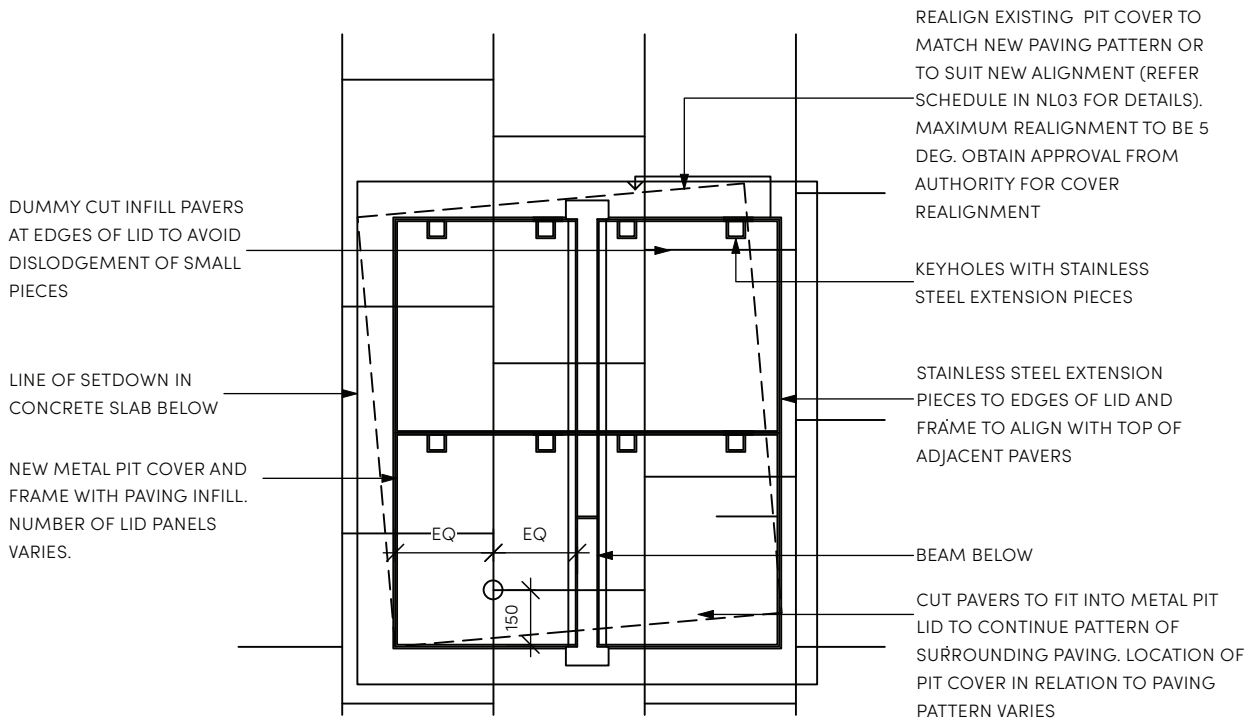

MULTI PART LID PLAN 1:20

NOTE
IF REQUIRED EXTEND WALLS WITH NEW CONCRETE TO ENG. DETAILS TO RAISE TOP OF PIT TO SUIT NEW PAVING LEVEL.

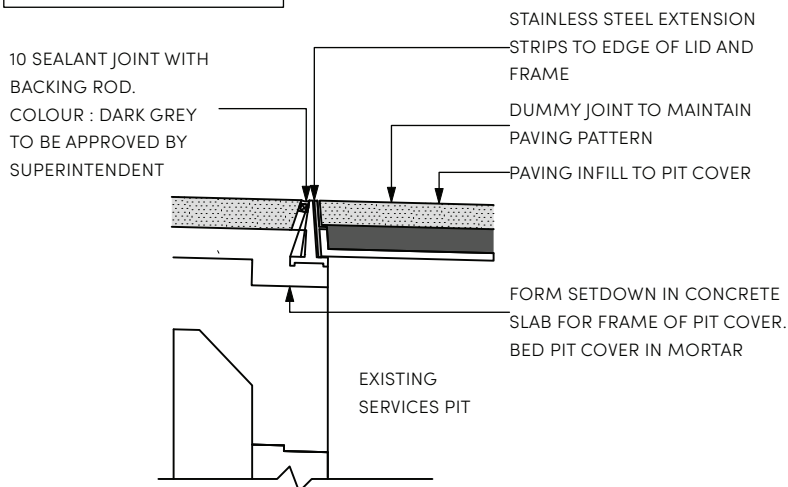

MULTI-PART LID SECTION 1:10

3.1 Pavements and Levels Changes

3.1.6 Pavements and Levels Changes Guidelines

Application

- Urban Area and Parklands
- Trench grate are used in areas where efficient surface water drainage is required over a linear span, especially where water runoff needs to be collected quickly and safely.

Product/ Material

- Trench Grate as specified by Landscape Architect or Civil Engineers;
- To footpath (including driveway access) and shared zone, infill pit lid to be Class C maximum;
- To carriageway, grate to be Class D, and
- Ductile iron heel guard trench grate to be applied to pedestrian areas.

Supplier

As approved by the Authority

Construction Notes

- Concrete surround to be set down below pavement surface.
- Grate to be lockable.
- Metal pits only to be used.
- Openings to comply with AS 1428.
- Finish grate 3mm max. below pavement surface level.

Also refer to Sydney Olympic Park

Authority's IECM:

- SW006

Typical Trench Grate



Sample - Trench grate

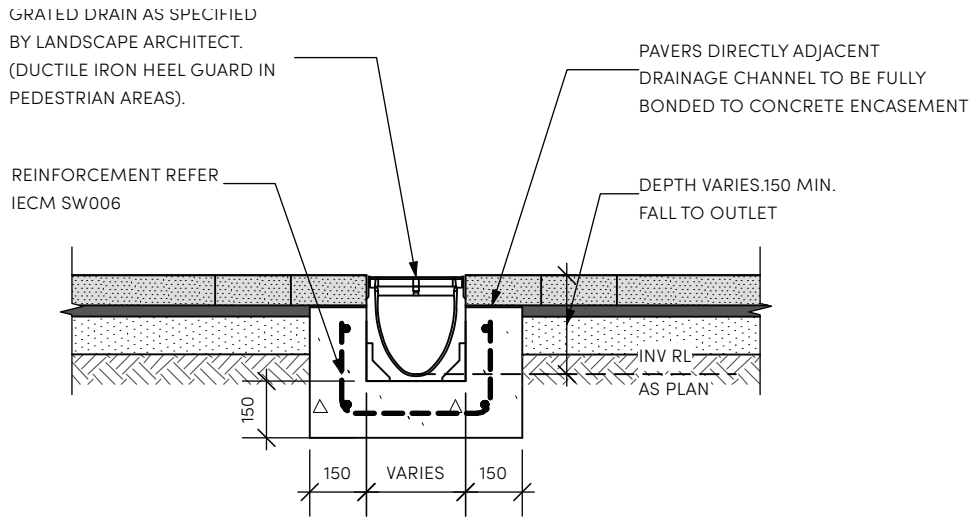

TRENCH GRATE IN PAVED PAVEMENT 1:20

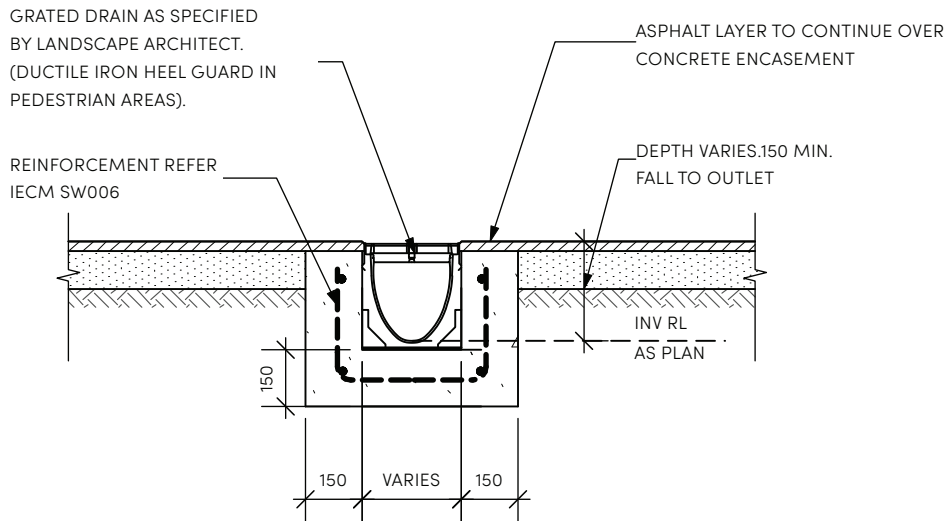

TRENCH GRATE IN ASPHALTIC PAVEMENT 1:20

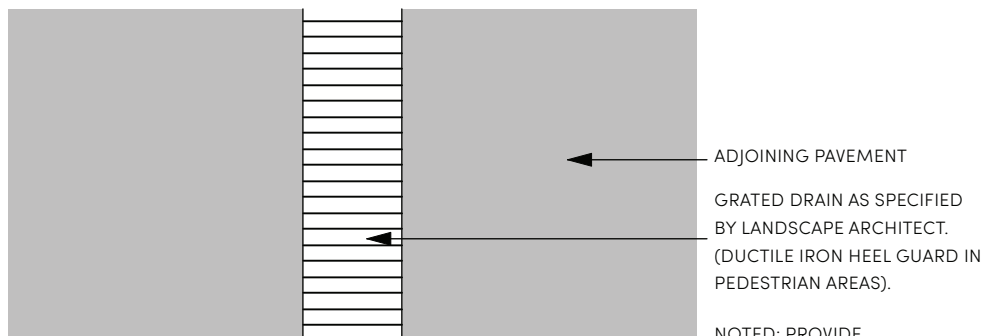

PLAN 1:20

NOTED: PROVIDE CONTINUOUS PAVEMENT SURFACE TO EDGE OF GRATED DRAIN

3.1 Pavements and Levels Changes

3.1.6 Pavements and Levels Changes Guidelines

Application

- Urban Area and Parklands
- This type of wall shall be used in urban core, Parklands entries, car parks and other zones where a high quality finish is desirable and/ or the use of gabion wall is not appropriate.

Product/ Material

- Off form concrete;
- White cement, selected sand 'Nepean river gravel' aggregate (20mm);
- Steel reinforcing;
- Light sand blasted finish;
- Vertical joints at 2000mm max. centres, and
- Matt finish anti graffiti paint

Supplier

As approved by the Authority

Construction Notes

- Installation to engineers final specification.
- If wall height is greater than 1000mm above pavement it will require balustrade to meet AS 1428 and Sydney Olympic Park Authority Access Guildelines.
- All concrete formed surface shall be in accordance with AS 3610.
- Wall can also be used as a freestanding element to act as support base for other attachments ie. sign, seats, bins, bike racks etc.

Also refer to Sydney Olympic Park Authority's IECM:

N/A

200mm Wide Insitu Concrete Retaining Wall



Sample - 200mm Wide insitu concrete retaining wall

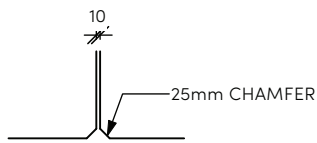

**TYPICAL VERTICAL JOINT
DETAIL PLAN 1:20**

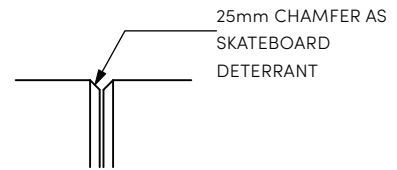

**TYPICAL VERTICAL JOINT DETAIL
- TOP OF WALL ELEVATION 1:20**

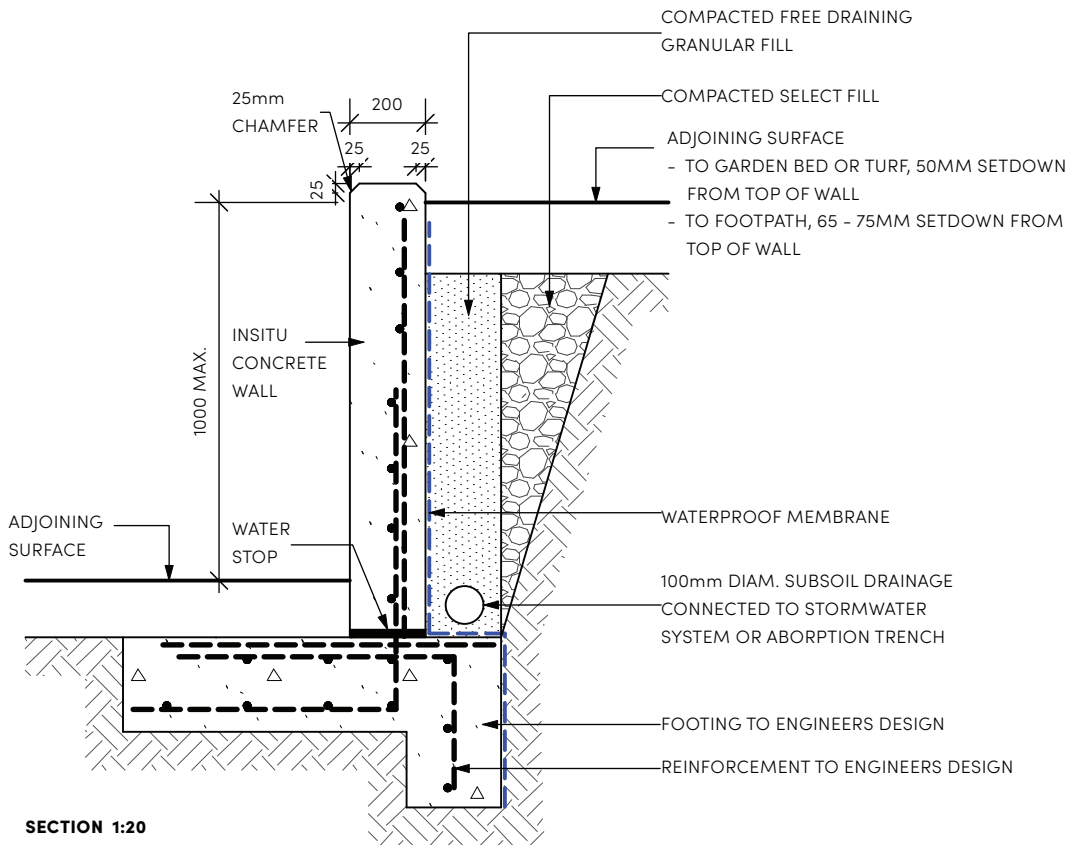

3.1 Pavements and Levels Changes

3.1.6 Pavements and Levels Changes Guidelines

Application

- Urban Area and Parklands
- It serves as a multi-functional seating element in the Public Domain and to resolve changes of level.

Product/ Material

- Insitu concrete wall class 2 finish;
- Colour – off white (colour sample to be approved by Sydney Olympic Park Authority), and
- Graffiti barrier to all external wall faces (no visible colour) to meet Sydney Olympic Park Authority standards.

Supplier

As approved by the Authority

Construction Notes

- Installation to engineers final specification.
- Top of walls to be a consistent RL. Wall to have 25mm chamfer to all edges
- If wall height is greater than 1000mm above pavement it will require balustrade to meet AS 1428 and Sydney Olympic Park Authority Access Guidelines.
- All concrete formed surface shall be in accordance with AS 3610.
- Sitting wall shall be 450mm high max. above surface level.

Also refer to Sydney Olympic Park Authority's IECM:

- W002

400mm Wide Insitu Concrete Wall



Sample - 400mm Wide Insitu concrete wall

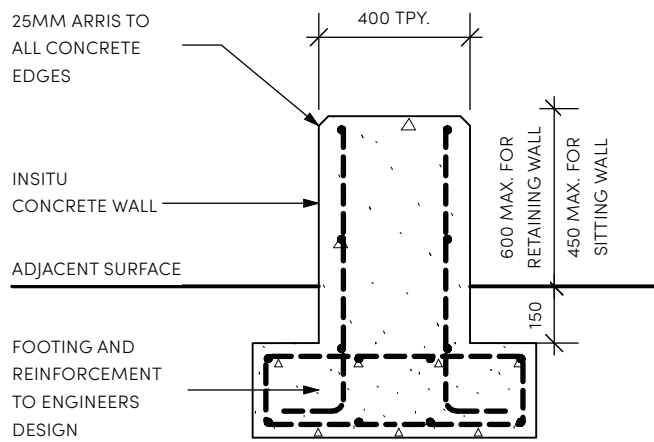

INSITU FREE STANDING CONCRETE SEAT WALL 1:20

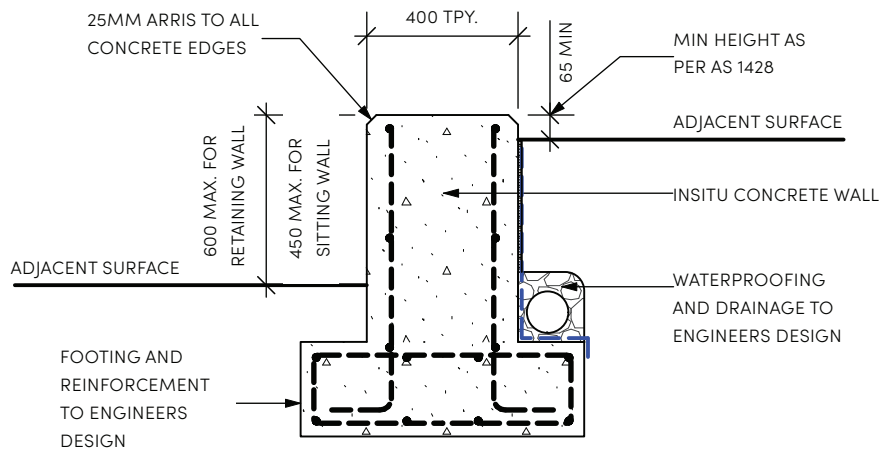

INSITU CONCRETE RETAINING SEAT WALL 1:20

3.1 Pavements and Levels Changes

3.1.6 Pavements and Levels Changes Guidelines

Application

- Urban Area and Parklands
- This type of wall shall be used where there is level change and a natural finish is desirable.
- Not to be used for level changes under awnings or colonnades.

Product/ Material

- Galvanised prefabricated wire baskets filled with basalt or sandstone rock to engineers specification
- Preferred basket size as shown on the drawing
- Product as specified by Landscape Architect or Engineers

Supplier

As approved by the Authority

Construction Notes

- Installation to engineers final specification.
- Rock should be hand faced to suit. It can be machine placed if not visually significant.

Also refer to Sydney Olympic Park

Authority's IECM:

- W001

Typical Gabion Wall



Sample - Gabion wall

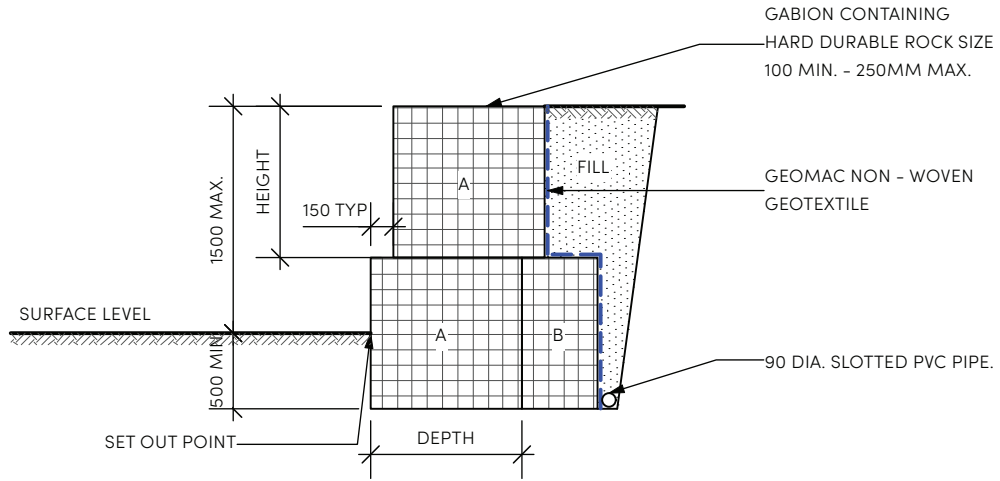

TYPE 1 (0M -1.5M HIGH) 1:50

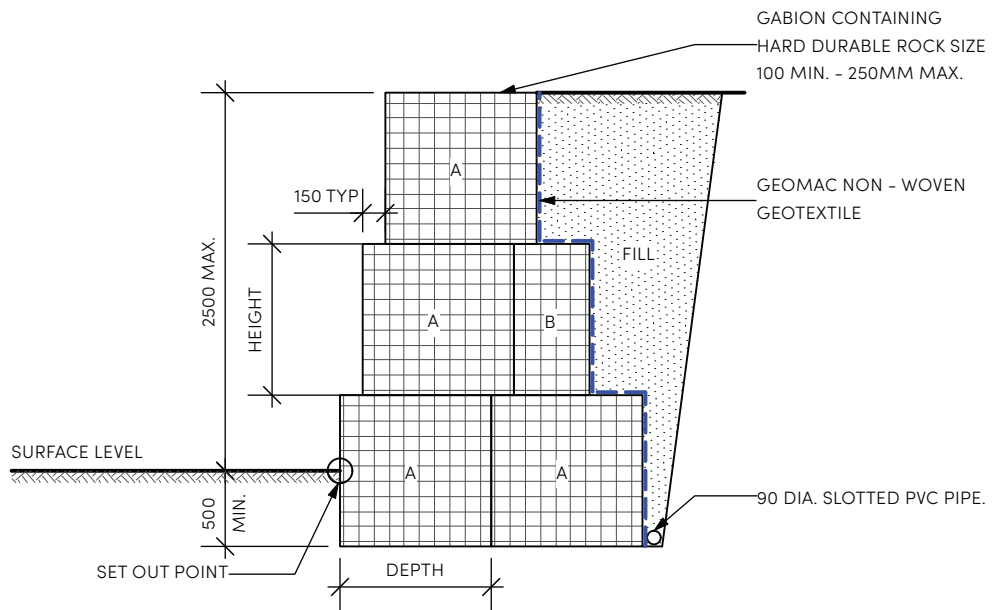

TYPE 2 (1.5M -2.5M HIGH) 1:50

GABION BASKET DIMENSIONS

TYPE	LENGTH	DEPTH	HEIGHT
A	2000	1000	1000
B	2000	500	1000
C	2000	1000	500

ROCK TYPE TO BE BASALT OR SANDSTONE TO LANDSCAPE ARCHITECT'S SPECIFICATION

3.1 Pavements and Levels Changes

3.1.6 Pavements and Levels Changes Guidelines

Application

- Urban Area
- At the interface between difference surface

Product/ Material

- 80x5mm Galvanised mild steel edge

Supplier

As approved by the Authority

Construction Notes

- Position steel edging vertically in ground with top edge flush with the finished levels.
- Securely fix pegs every 1m cts on the adjoining surface side.
- Peg to be 250x10ømm galvanised mild steel below the surface.
- Provide galvanised steel plate at joints.

Also refer to Sydney Olympic Park

Authority's IECM:

- P007

Steel Edge



Sample - Steel edge

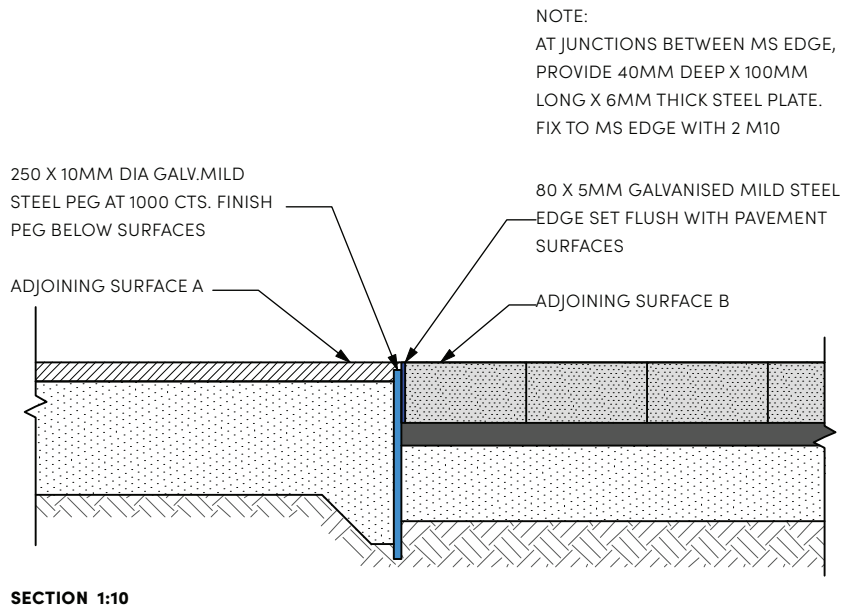
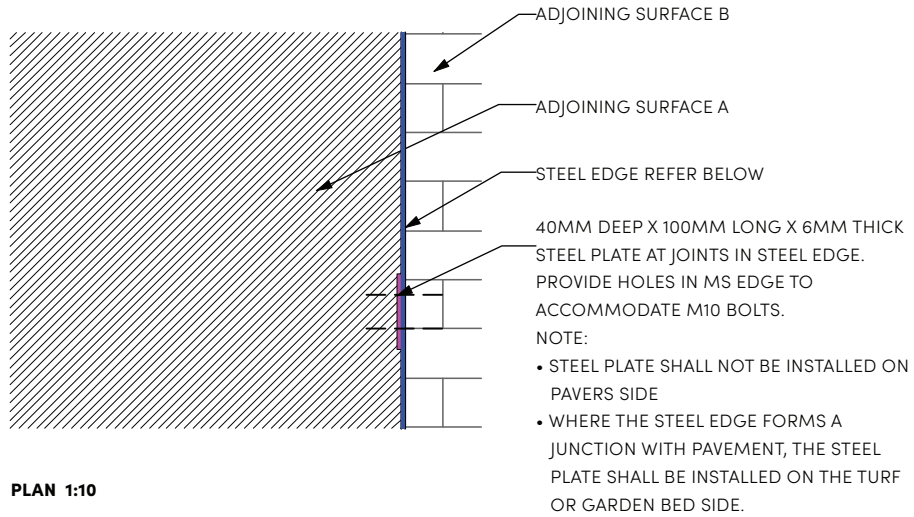

Sydney Olympic Park Design Manual

FURNITURE

3.2

Street Furniture elements form an integral part of the Sydney Olympic Park public domain identity, and facilitate use and enjoyment of the public domain

The elements are functional and ergonomic with strong simple forms. The range includes catalogue items, assembled items and custom made items:

- Catalogue items are available from product manufacturers' existing product ranges.
- Assembled items are those elements created by the combination of standard readily available components.
- Custom items have been developed where no equivalent or appropriate product exists; these items have been kept to a minimum.

It is envisaged that the range of street furniture will be augmented if new elements become necessary. It is also envisaged that from time to time one off custom pieces of street furniture may be designed, as part of the public art program, or for special public places and parks. One off pieces should be compatible with the main street furniture palette.

Guidelines include:

- seating
- picnic tables
- drinking fountains
- bin enclosures
- bollards
- bike racks
- barbeques
- tree grates
- movable furniture
- in ground planter boxes
- flag poles
- fencing
- vehicle barriers
- handrails
- Flag poles
- Fencing
- Vehicle barriers
- Handrails

3.2 Furniture

3.2.1 Objectives

Street furniture at Sydney Olympic Park is to achieve the following objectives:

- reinforce the public domain character;
- create a comprehensive and coordinated range;
- be appropriately placed for convenient use;
- be sufficiently robust to withstand heavy use by large crowds during events;
- be sufficiently flexibility to suit different use areas;
- use a minimal and consistent palette of materials;
- achieve environmental principles; and
- minimise life cycle costs and maintenance requirements.

3.2.2 Relevant Standards

The Street Furniture guidelines are to be read in conjunction with the latest edition of all relevant Australian Standards. Where Australian Standards do not exist, appropriate International Standards will apply.

Relevant Australian Standards include but are not limited to the following:

- AS 1428 Design for Access and Mobility.

3.2.3 Procurement

Procurement of urban elements must comply with the NSW Government's procurement policies.



3.2 Furniture

3.2.4 Furniture Guidelines

Application

- Urban Area
 - Pedestrian Spaces
 - High Activity Transit Malls
 - Civic and High Streets
 - Intersections
 - Major crossings
 - Urban Parks
- Parklands
 - Major parklands tracks
 - Major Entries
 - Recreation hubs
- Provide opportunities for longer sitting stays.
- Provide a single seating direction.
- Face seats towards dominant view or pedestrian thoroughfare, unless otherwise directed by Sydney Olympic Park Authority.
- Set out seat as per the guidelines on the next page.
- Do not install seats on slopes steeper than 1:20.

Product/ Material

- Aria Seat (CMA1-3S)
 - 3-Seater
 - Size: 1800L x 535W x 790H
 - Legs and mounting: 13 Aria Pedestal, subsurface fixing to pavers, surface fixing to concrete
 - Frame: Powder coated frame, Textura Woodland grey
 - Battern: Aluminium spotted gum woodgrain
 - End arm rest: 2

Supplier

Street Furniture Australia

Address: N6 Regents Park Estate, 391 Park Road
Regents Park NSW 2143

Phone: 02 8774 8888

Web: <https://streetfurniture.com/>

Backed Seat



Sample - Backed seat

Construction Notes

- Install furniture as per manufacturers' recommendations.
- Ensure the seat is installed plumb and level, with the centerline of the seat elevation positioned at a maximum height of 440mm above the finished surface. Where the adjoining surface is sloped, custom leg lengths may be required to achieve this height while maintaining a plumb and level installation.

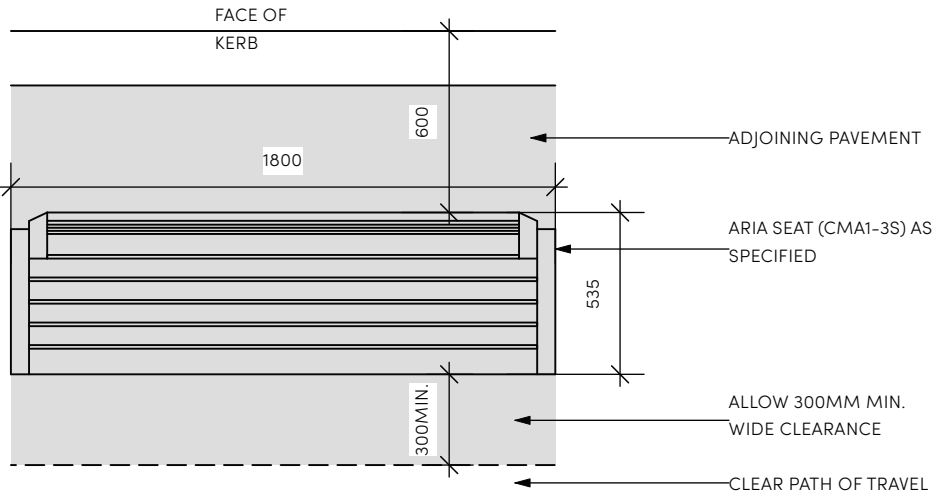

PLAN - STREET ARRANGEMENT 1:25

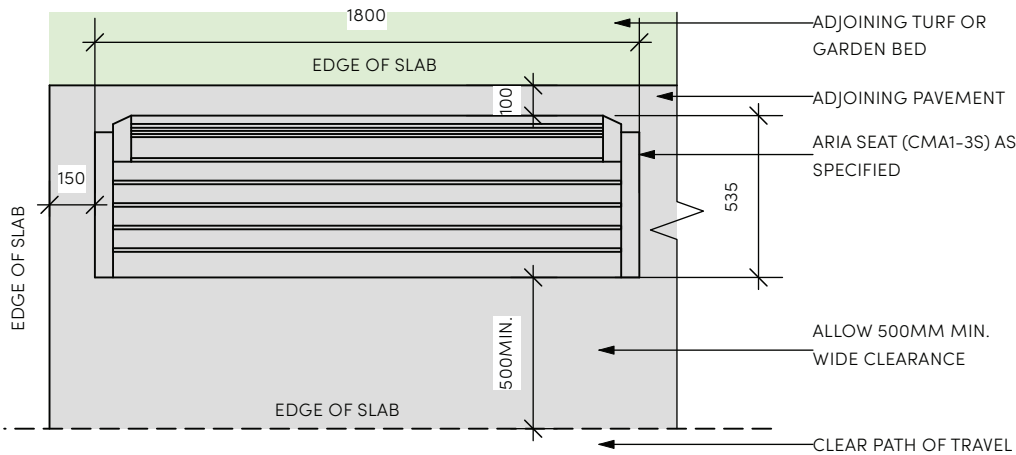

PLAN - PARK OR PARKLANDS ARRANGEMENT 1:25

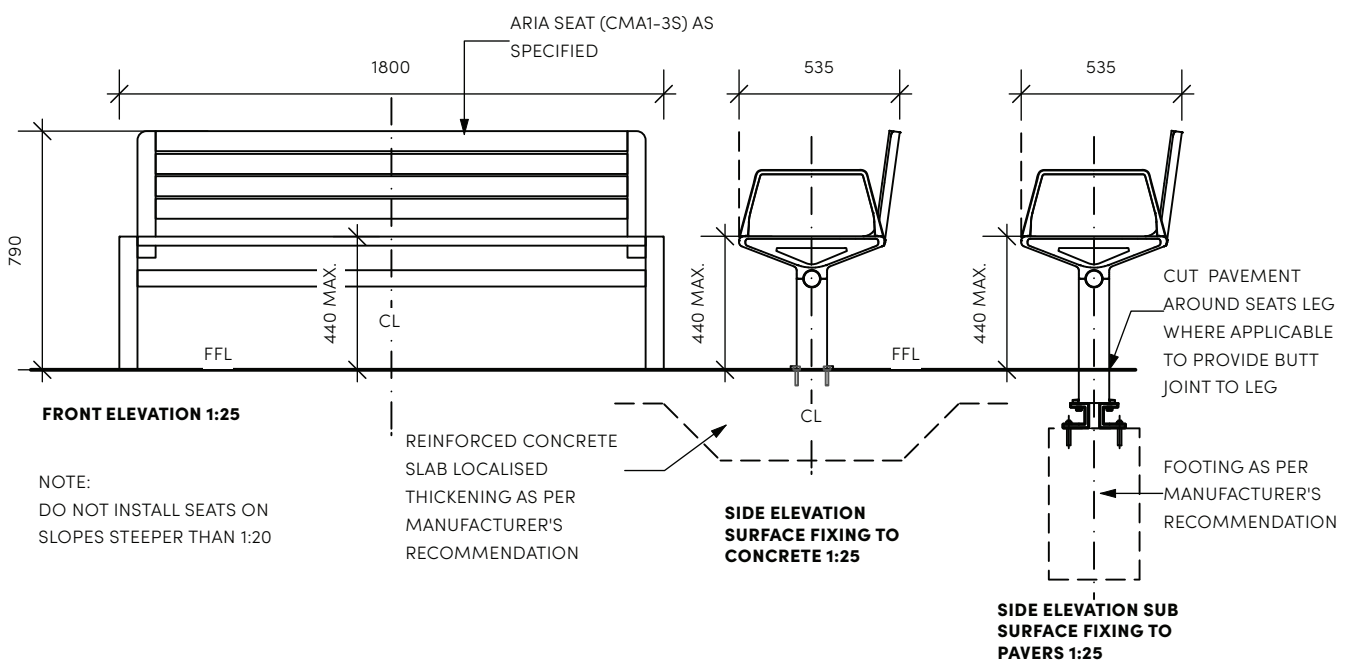

FRONT ELEVATION 1:25

NOTE:
DO NOT INSTALL SEATS ON SLOPES STEEPER THAN 1:20

3.2 Furniture

3.2.4 Furniture Guidelines

Application

- Urban Area
 - Pedestrian Spaces
 - High Activity Transit Malls
 - Civic and High Streets
 - Intersections
 - Major crossings
 - Urban Parks
- Parklands
 - Major parklands tracks
 - Major Entries
 - Recreation hubs
- For use where there may be multiple suitable seating orientations - and users may sit facing in either direction.
- Face benches towards dominant view or pedestrian thoroughfare, unless otherwise directed by Sydney Olympic Park Authority.
- Set out bench as per the guidelines on the next page.
- Do not install benches on slopes steeper than 1:20.

Product/ Material

- Aria Bench (CMA4-3B) or equivalent as approved by the Authority
 - 3-Seater
 - Size: 1800L x 485W x 440H
 - Legs and mounting: 13 Aria Pedestal, subsurface fixing to pavers, surface fixing to concrete
 - Frame: Powder coated frame, Textura Woodland grey
 - Battern: Aluminum spotted gum woodgrain
 - End arm rest: None

Supplier

Street Furniture Australia

Address: N6 Regents Park Estate, 391 Park Road
Regents Park NSW 2143

Phone: 02 8774 8888

Web: <https://streetfurniture.com/>

Bench Seat



Sample - Bench seat

Construction Notes

- Install furniture as per manufacturers' recommendations.
- Ensure the bench is installed plumb and level, with the centerline of the bench elevation positioned at a maximum height of 440mm above the finished surface. Where the adjoining surface is sloped, custom leg lengths may be required to achieve this height while maintaining a plumb and level installation.

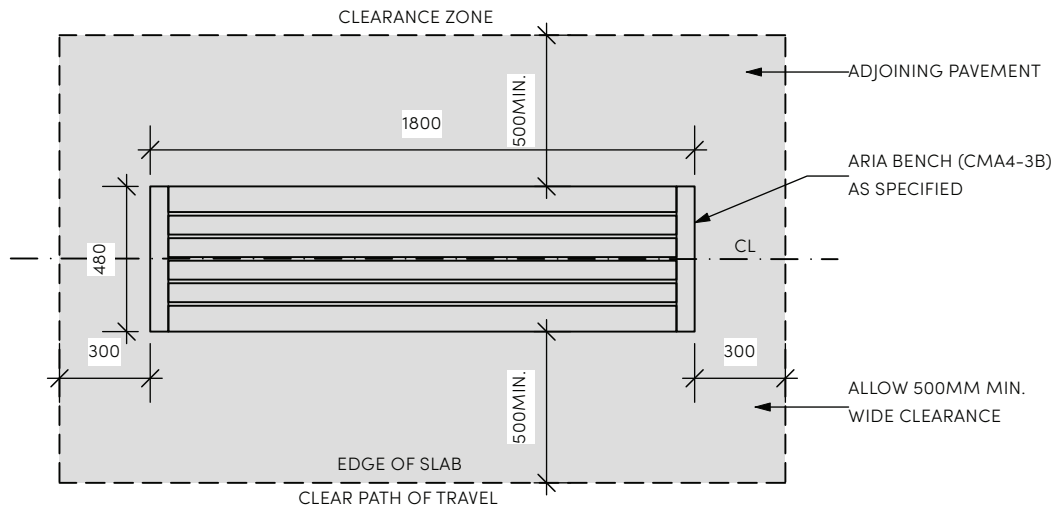

PLAN - BENCH SEAT 1:25

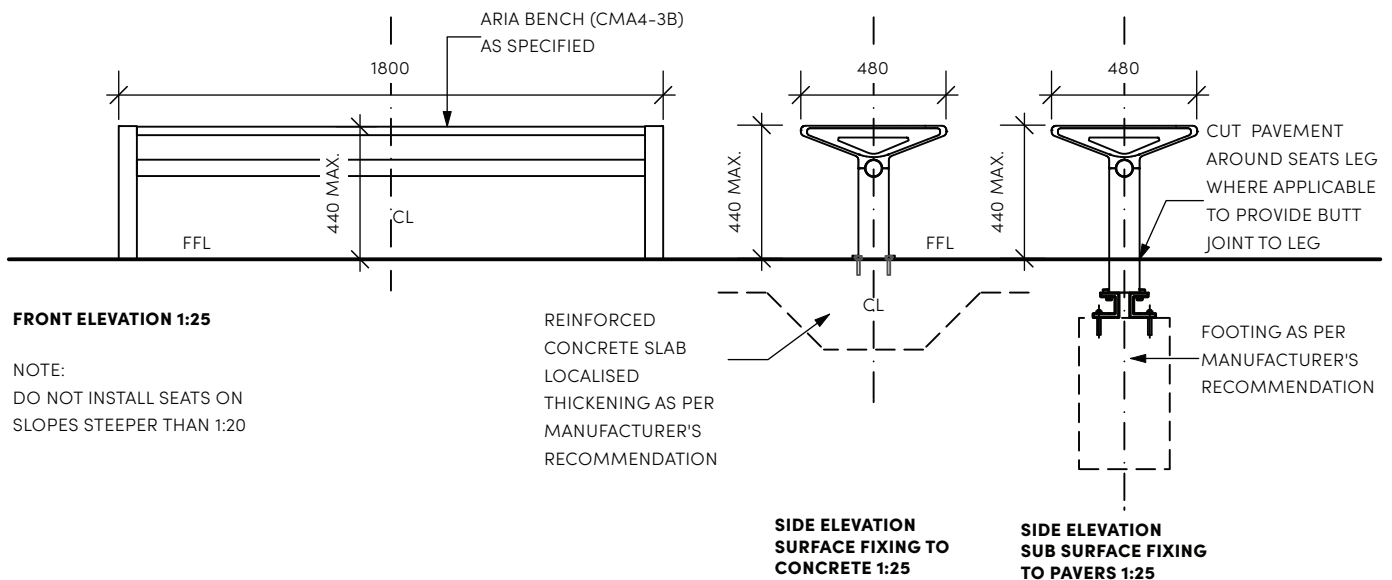

FRONT ELEVATION 1:25

NOTE:
DO NOT INSTALL SEATS ON
SLOPES STEEPER THAN 1:20

**SIDE ELEVATION
SURFACE FIXING TO
CONCRETE 1:25**

**SIDE ELEVATION
SUB SURFACE FIXING
TO PAVERS 1:25**

3.2 Furniture

3.2.4 Furniture Guidelines

Application

- Parklands
 - Waterfront
- To be used as seating/ edge along the Foreshore Walk - Paramatta River and Homebush Bay.

Product/ Material

- 40MPa concrete with timber off form finish to top, side and ends
- Size: 3000L x 300W x 450H

Supplier

Sydney Precast

Address: Gate 1, Western Collector Road Ropes
Crossing NSW 2760

Phone: 02 9748 7610

Web: <https://www.sydneyprecast.com.au/>

Construction Notes

- Install furniture as per manufacturers' recommendations.
- Ensure the bench is installed plumb and level, with a maximum height of 450mm above the finished surface. Where the adjoining surface is sloped, custom leg lengths may be required to achieve this height while maintaining a plumb and level installation.

Waterfront Bench



Sample - Waterfront bench seat

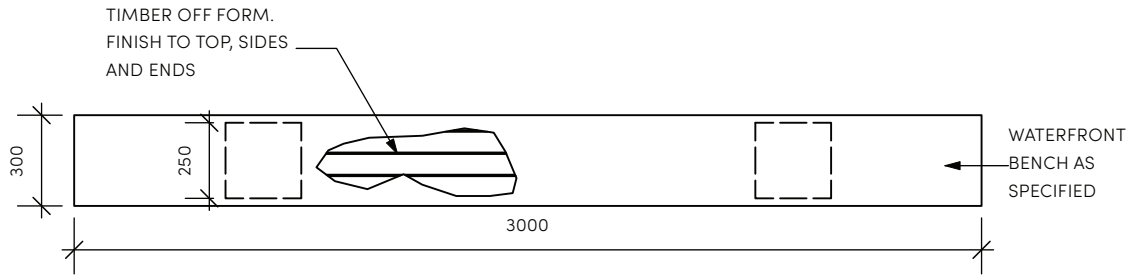

PLAN - WATERFRONT BENCH 1:25

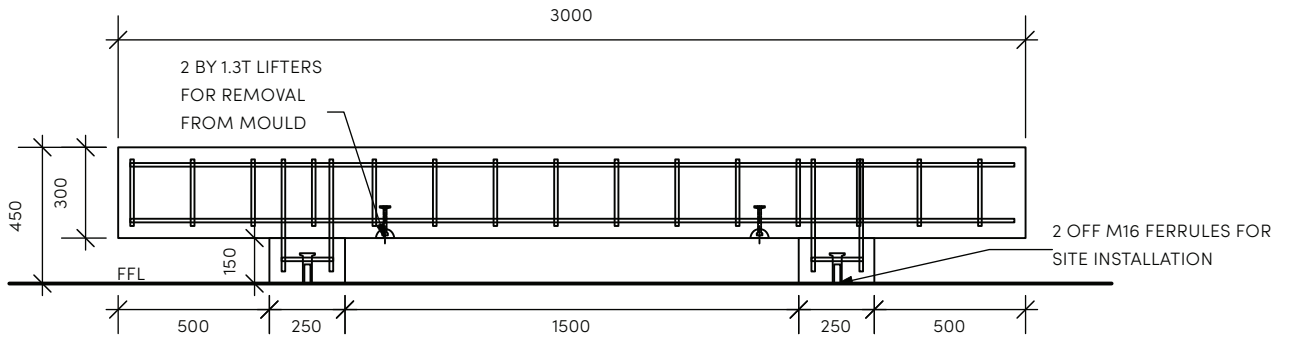

FRONT ELEVATION 1:25

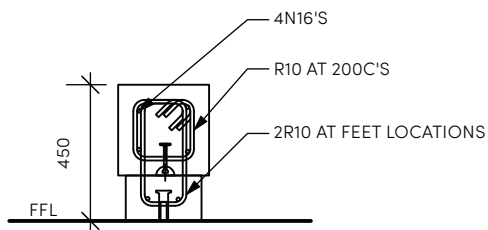

SECTION 1:25

NOTES:

1. 40MPA CONCRETE
2. 40MM COVER TO ALL REINFORCEMENT
3. CLASS 2 CHARCOAL CONCRETE
4. TIMBER OFF FORM FINISH TO ALL FACES APART FROM BOTTOM

3.2 Furniture

3.2.4 Furniture Guidelines

Application

- Urban Area
 - Urban Parks
- Parklands
 - Recreation hubs
- Locate in a shady position (or when a number of picnic tables area provided - a variety of locations in both sun and shade).
- Locate with paved access to adjoining path systems.
- Consider provision of picnic tables in comfortable walking distance from parking.
- Locate to facilitate access by users including wheelchair access.
- Set out table set as per the guidelines on the next page.
- Do not install picnic table set on ground that is steeper than 1:40.

Product/ Material

- Aria DDA Table (CMA6-DDA) or Aria Table (CMA6)
 - Size:
 - 1800 or 2100L x 705W x 830H (DDA)
 - 1800L x 705W x 720H (standard)
 - Legs and mounting: 14 Aria Pedestal, subsurface fixing to pavers, surface fixing to concrete
 - Frame: Powder coated frame, Textura Woodland grey
 - Battern: Alumimum spotted gum woodgrain. Battern endcap colour to match frame
 - DDA table wheelchair access from 1 end or from both ends, subject to final design
- Aria Bench (CMA4)
 - Size:
 - 1800L x 485W x 485H for wheelchair access from 1 end (DDA)
 - 2100L x 485W x 485H for wheelchair access from both ends (DDA)
 - 1800L x 485W x 440H (standard)
 - Legs and mounting:
 - 16 Aria Pedestal Talll (DDA)

Picnic Table Set



Sample - Picnic table set (DDA)

- 13 Aria Pedestal (standard)
- Subsurface fixing to pavers, surface fixing to concrete
- Frame: Powder coated frame, Textura Woodland grey
- Battern: Alumimum spotted gum woodgrain
- End arm rest: None

Supplier

Street Furniture Australia

Address: N6 Regents Park Estate, 391 Park Road
Regents Park NSW 2143

Phone: 02 8774 8888

Web: <https://streetfurniture.com/>

Construction Notes

- Install furniture as per manufacturers' recommendations.
- Ensure the table and benches are installed plumb and level, with a maximum height nominated above the finished surface. Where the adjoining surface is sloped, custom leg lengths may be required to achieve this height while maintaining a plumb and level installation.

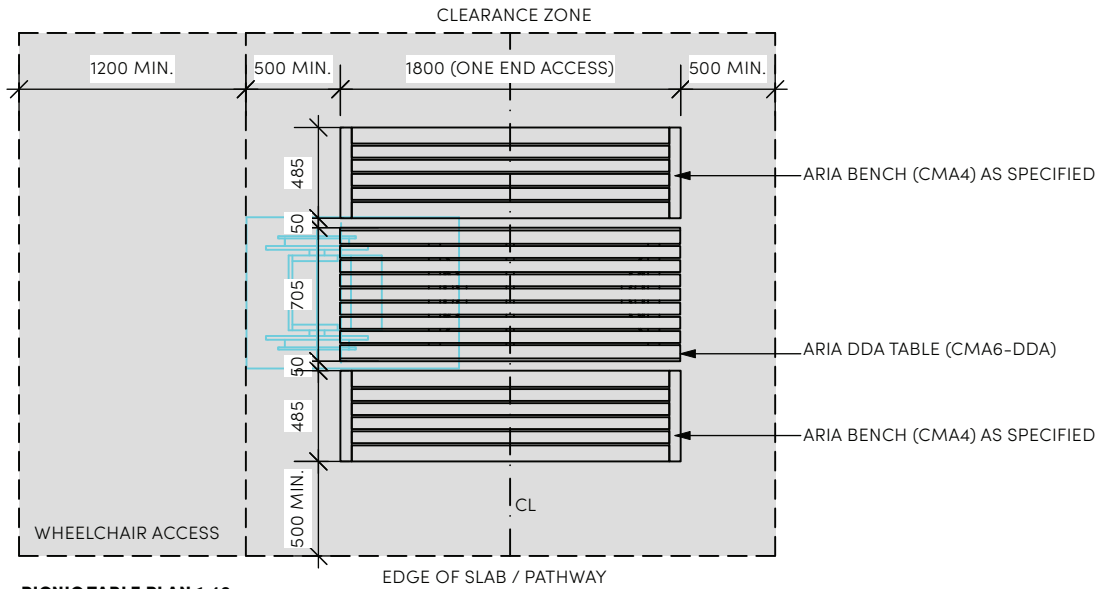

PICNIC TABLE PLAN 1:40

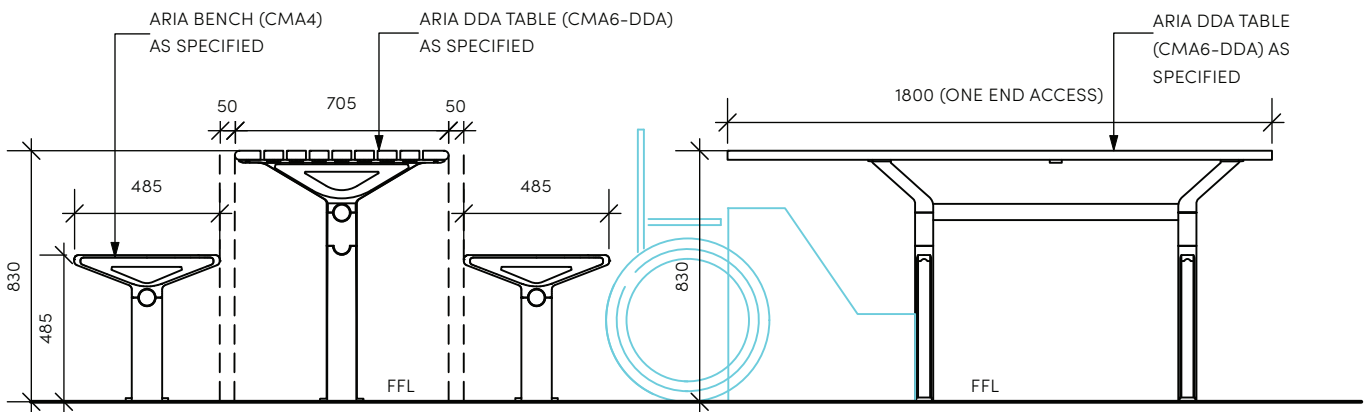

SIDE ELEVATION 1:25

FRONT ELEVATION 1:25

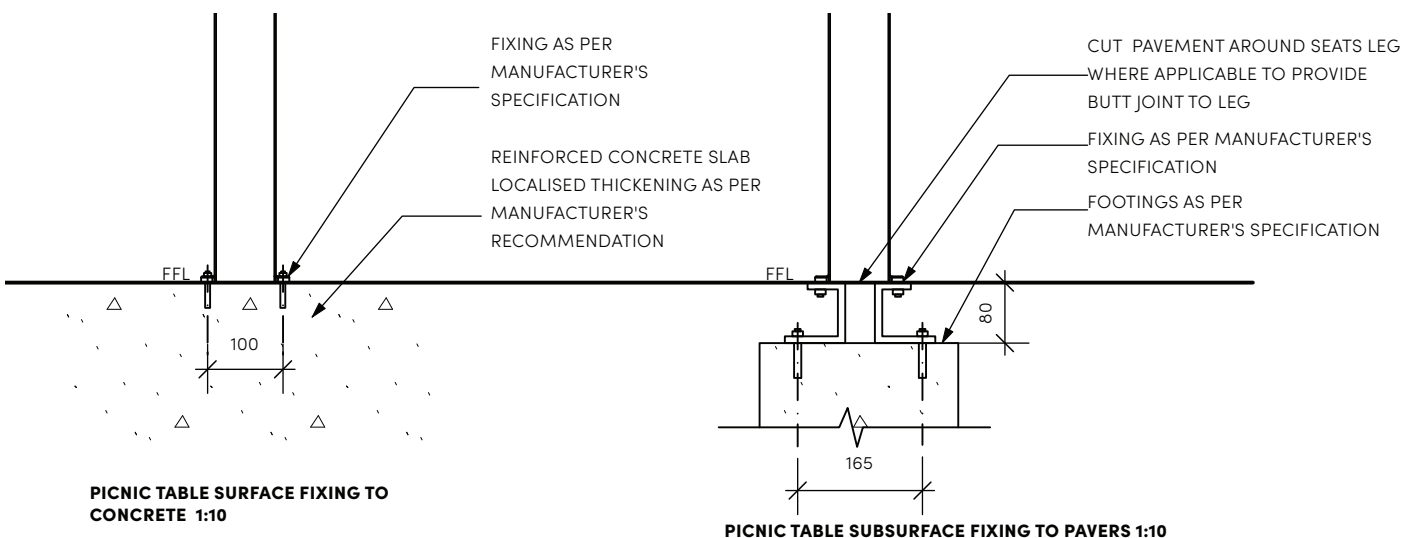

PICNIC TABLE SURFACE FIXING TO CONCRETE 1:10

PICNIC TABLE SUBSURFACE FIXING TO PAVERS 1:10

3.2 Furniture

3.2.4 Furniture Guidelines

Application

- Urban Area
 - Pedestrian Spaces
 - High activity transit malls
 - Intersections
 - Major crossings
 - Urban Parks
 - Bike paths or shared paths
- Locate to facilitate access by users including wheelchair access.
- Set out drinking fountain as per the guidelines on the next page.

Product/ Material

- Aquafil Flexifountain 1500BF (AQ-FF1500BF)
- Customisation options to be confirmed with Sydney Olympic Park Authority

Supplier

Civiq

Address: 4 Dawn Fraser Avenue Sydney Olympic Park
NSW 2127

Phone: 1300 600 300 (sales), Opt 1

Web: <https://civiq.com.au/>

Construction Notes

- Install furniture as per manufacturers' recommendations.
- Ensure the drinking fountain is installed plumb and level.

Drinking Fountain – Urban Area



Sample - Drinking fountain - urban area

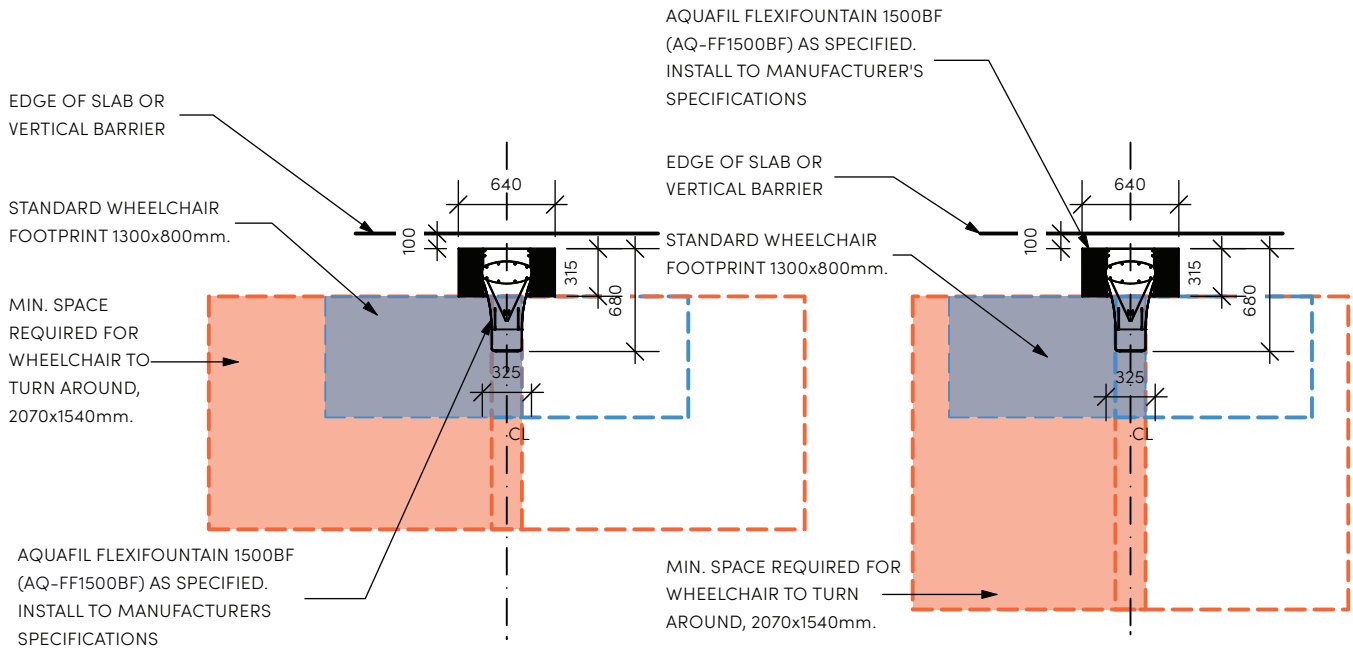

PLAN - ARRANGEMENT OPTION 1 1:50

PLAN - ARRANGEMENT OPTION 2 1:50

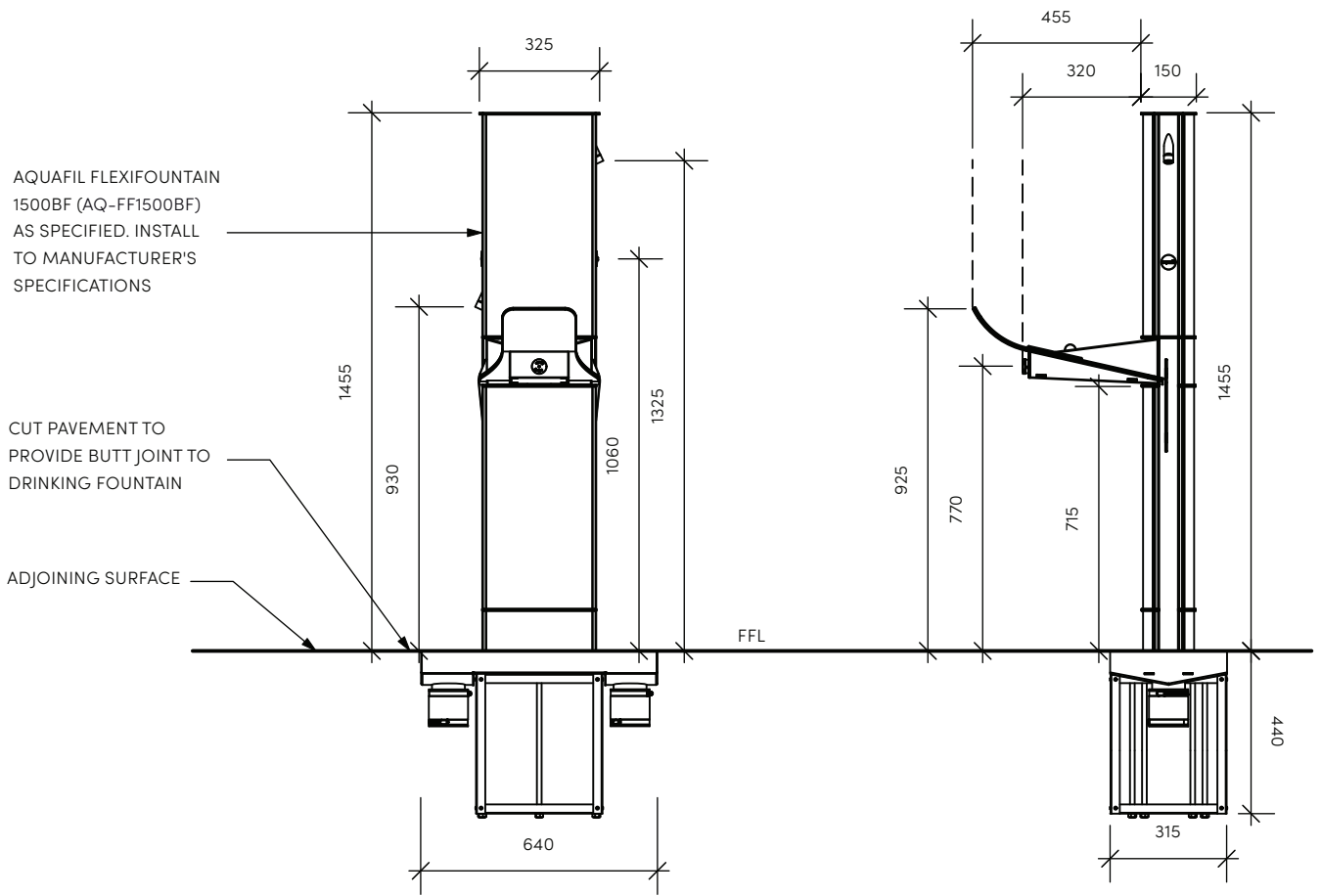

FRONT ELEVATION 1:20

SIDE ELEVATION 1:20

3.2 Furniture

3.2.4 Furniture Guidelines

Application

- Parklands
 - Bike paths or shared paths
 - Major Entries
 - Recreation hubs
- Locate to facilitate access by users including wheelchair access.
- Set out drinking fountain as per the guidelines on the next page.

Product/ Material

- Prospect drinking fountain
- Customisation options to be confirmed with Sydney Olympic Park Authority

Supplier

Botton & Gardiner

Address: 53-55 Whiting Street Artarmon NSW 2064

Phone: 1300 762 701

Web: <https://www.bottongardiner.com.au/>

Construction Notes

- Install furniture as per manufacturers' recommendations.
- Ensure the drinking fountain is installed plumb and level.

Drinking Fountain - Parklands



Sample - Drinking fountain - parklands

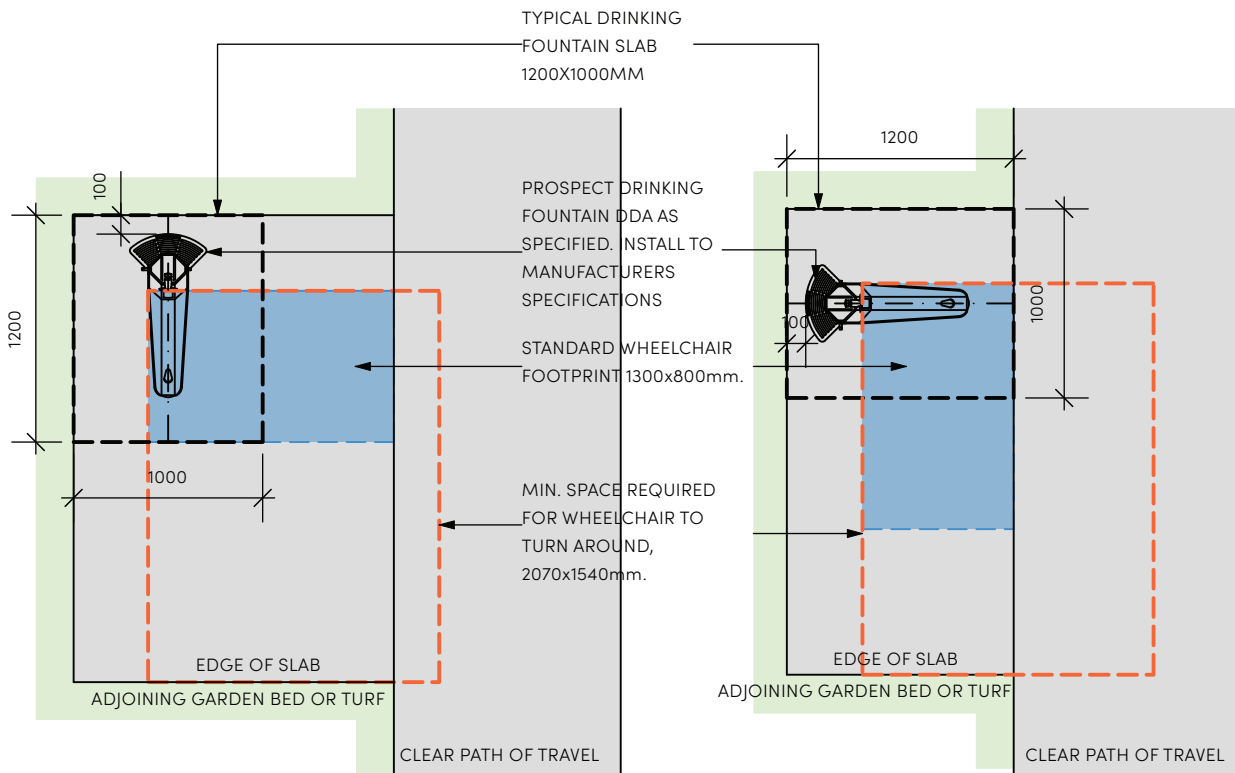

PLAN - ARRANGEMENT OPTION 1 1:40

PLAN - ARRANGEMENT OPTION 2 1:40

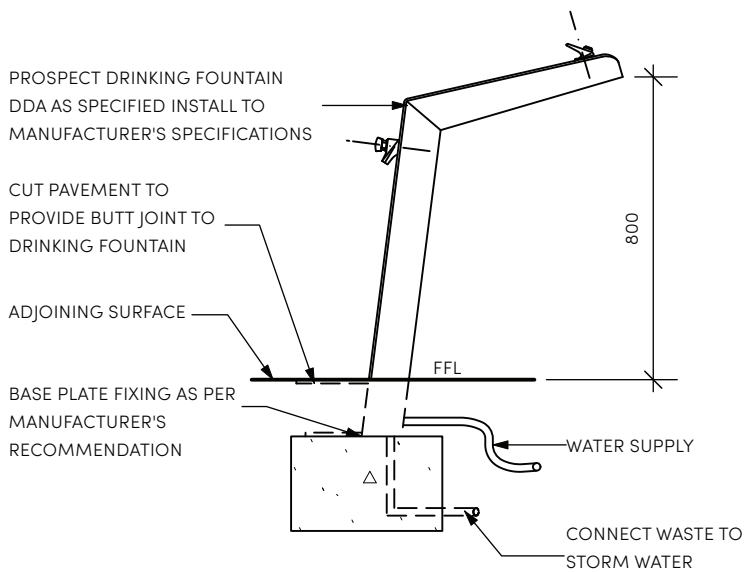

SECTION 1:20

3.2 Furniture

3.2.4 Furniture Guidelines

Application

- Urban Area
 - Pedestrian spaces
 - High activity transit malls
 - Civic and High Streets
 - Intersections
 - Major crossings
 - Urban Parks
- Parklands
 - Major parklands tracks
 - Major Entries
 - Recreation hubs
- Use sparingly and in conjunction with other furniture items e.g. backed seat, bike rack, and drinking fountain at the major rest areas.
- Locate with considerations for vehicle access for easy emptying and maintenance.
- Set out bin enclosure as per the guidelines on the next page.

Product/ Material

- Escola Bin Enclosure (WBE-E240)
 - 240L x 3 bin enclosures as one group (garbage, recycle and organics)
 - Angled roof, powder coated finish (Lobster Red for garbage bin, Mustard for recycled bin and Viper Green for organics bin)
 - Powder coated body finish, Textura woodland grey
 - Slot opening insert, colour to match the angled roof
 - Slam lock with triangular key
 - Signage etched directly on paneled body
 - Surface fixing, provide concrete pad beneath the bin enclosures if they are located adjacent to pavers
 - Customisation options to be confirmed with Sydney Olympic Park Authority

Bin Enclosure



Sample - Bin enclosure

Supplier

Street Furniture Australia

Address: N6 Regents Park Estate, 391 Park Road
Regents Park NSW 2143

Phone: 02 8774 8888

Web: <https://streetfurniture.com/>

Construction Notes

- Install furniture as per manufacturers' recommendations.
- Ensure the bin enclosure is installed plumb and level.
- Ensure door is easily accessible and does not obstruct pedestrian thoroughfare or car parking.

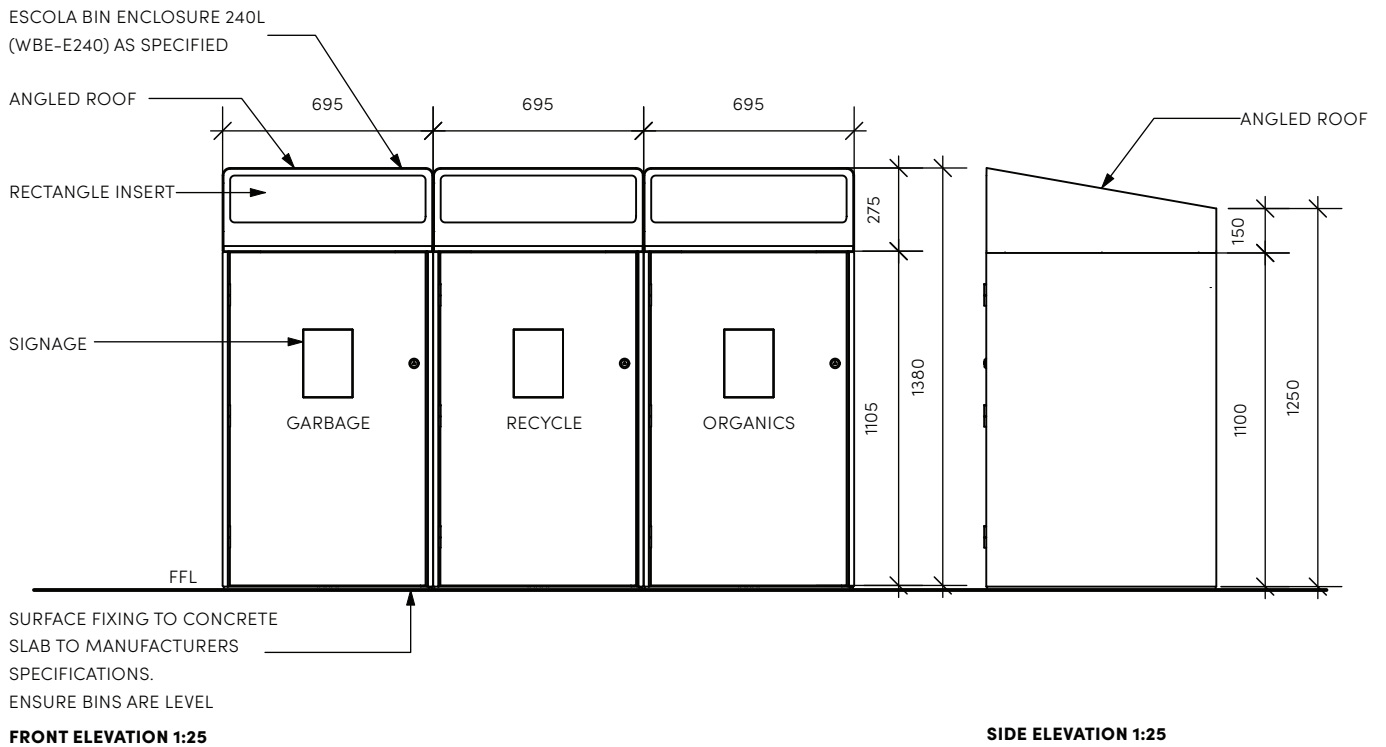
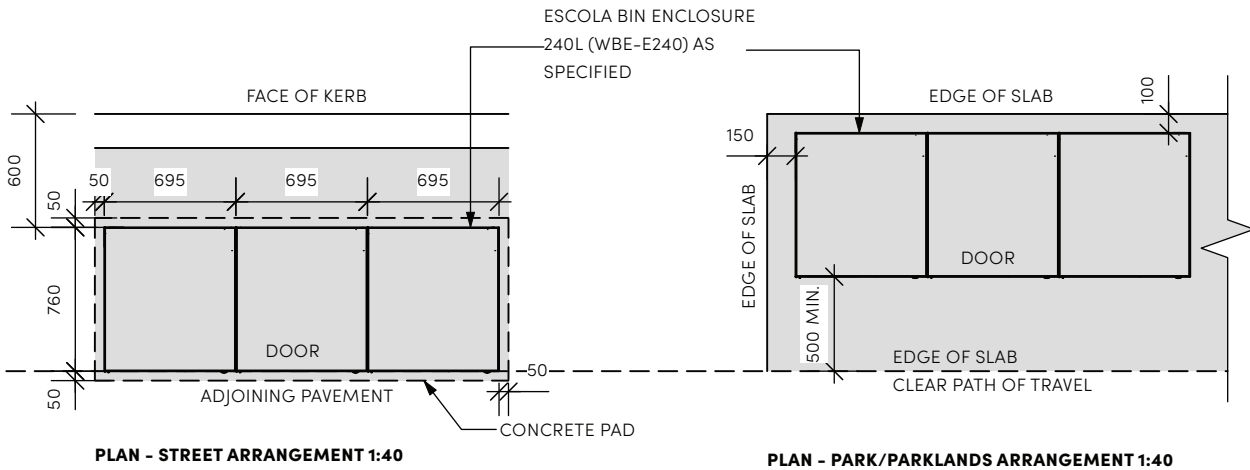

3.2 Furniture

3.2.4 Furniture Guidelines

Application

- Parklands
 - In conjunction with BBQ
- Set out bin enclosure as per the guidelines on the next page.

Product/ Material

- Hot Coal Bin (HCB120)
- Customisation options to be confirmed with Sydney Olympic Park Authority

Supplier

Scully Outdoor Designs Australia Pty Ltd
Address: 7D/1-3 Endeavour Road, Caringbah NSW
2229
Phone: 02 9531 4166
Web: <https://www.bottongardiner.com.au/>

Construction Notes

- Install furniture as per manufacturers' recommendations.
- Ensure the bin enclosure is installed plumb and level.
- Ensure door is easily accessible and does not obstruct pedestrian thoroughfare.

Hot Coal Bin



Sample - Hot coal bin

3.2 Furniture

3.2.4 Furniture Guidelines

Application

- Urban Area - generally
- Locate to prevent vehicles entering.
- Set out bollards as per the guidelines on the next page.

Product/ Material

- Slim bollard (B14-4)
 - Polished head finish
 - Stainless 316 No.4 finish (brush)
 - Subsurface fixing or removable in-ground
 - Other options to be confirmed with Sydney Olympic Park Authority

Supplier

Street Furniture Australia

Address: N6 Regents Park Estate, 391 Park Road
Regents Park NSW 2143

Phone: 02 8774 8888

Web: <https://streetfurniture.com/>

Construction Notes

- Install furniture as per manufacturers' recommendations.
- Ensure the bollards are installed plumb and level and in a constant alignment.

Bollard (General) - Urban Area



Sample - Bollard (general) - urban area

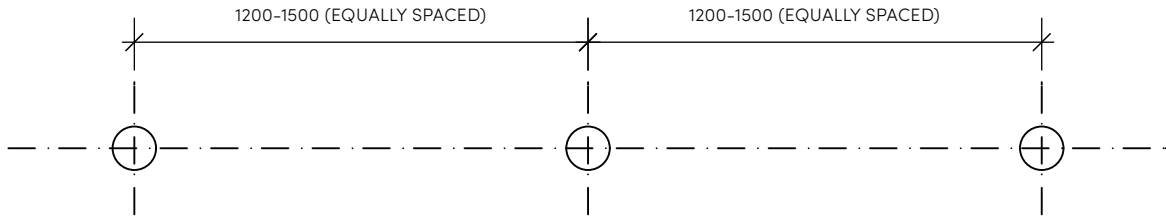

PLAN- TYPICAL ARRANGEMENT 1:20

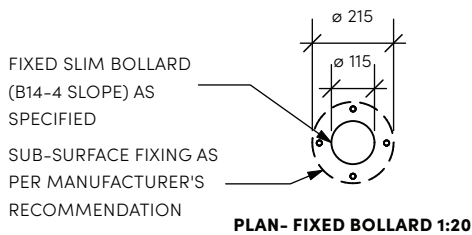

PLAN- FIXED BOLLARD 1:20

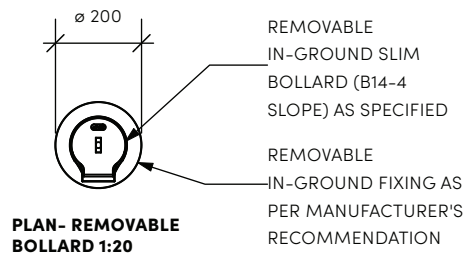

PLAN- REMOVABLE BOLLARD 1:20

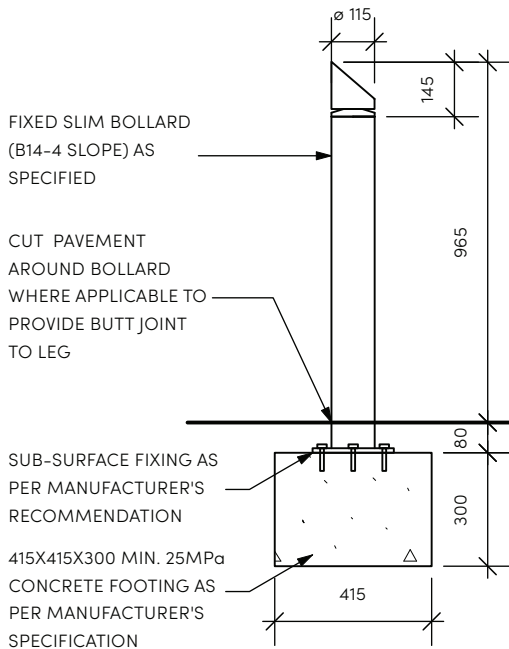

SECTION- FIXED BOLLARD 1:20

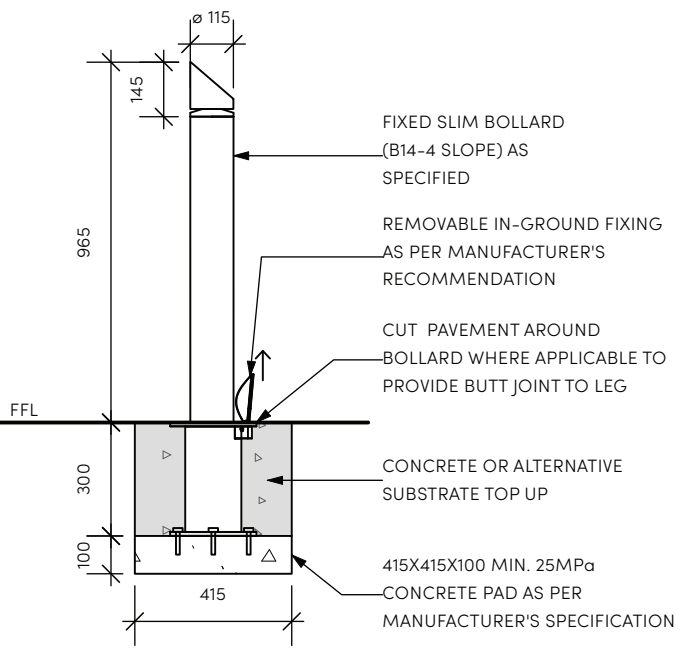

SECTION- REMOVABLE BOLLARD 1:20

3.2 Furniture

3.2.4 Furniture Guidelines

Application

- Urban Area - in particular the Stadia Precinct and Sports and Civic Precinct
- Locate to prevent vehicles entering.
- Set out bollards as per the guidelines on the next page.

Product/ Material

- Truckstopper 7-40
 - Stainless steel finish
 - Fixed or removable option, Subsurface fixing
 - Customisation options to be confirmed with Sydney Olympic Park Authority

Supplier

Ezi Security System

Address: 11 Cooper St Smithfield NSW 2164

Phone: 1300 558 304

Web: <https://www.ezisecurity.com.au/>

Construction Notes

- Install furniture as per manufacturers' recommendations.
- Ensure the bollards are installed plumb and level and in a constant alignment.

Bollard (Truckstopper) - Urban Area



Sample - Bollard (truckstopper) - urban area

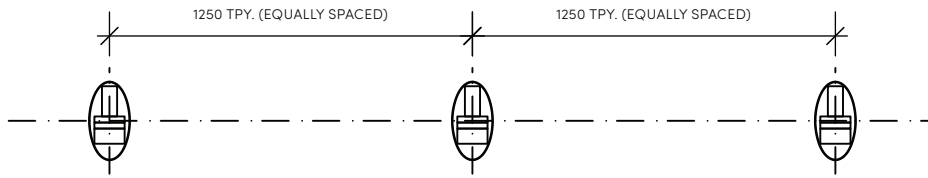

PLAN- TYPICAL ARRANGEMENT 1:20

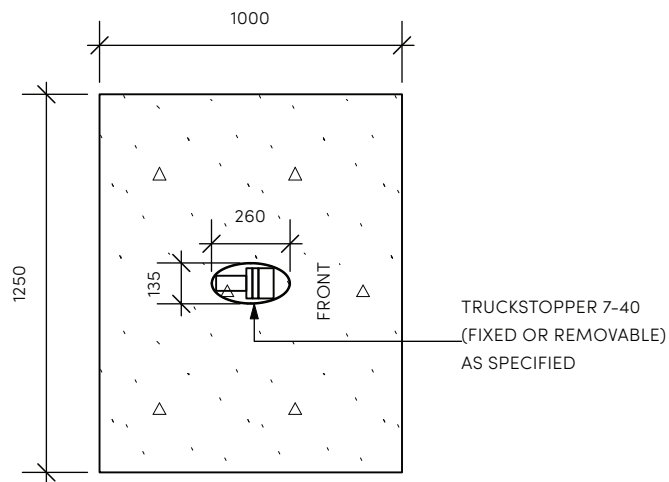

PLAN 1:25

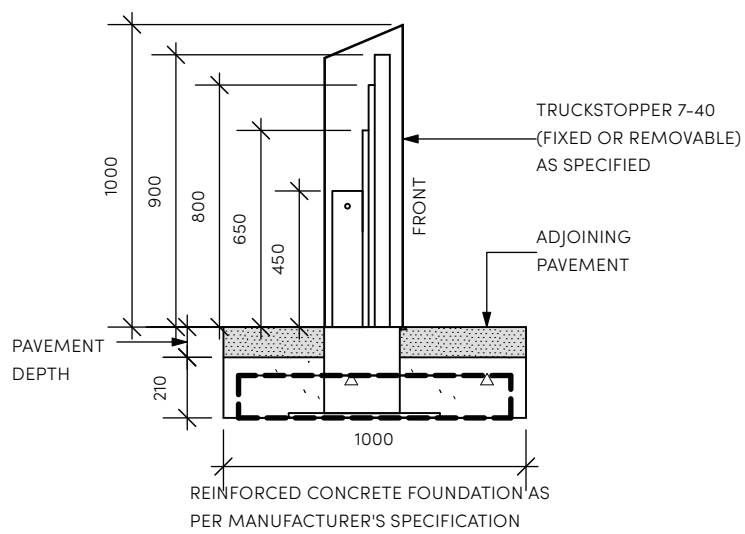

SIDE SECTION 1:25

3.2 Furniture

3.2.4 Furniture Guidelines

Application

- Parklands
- Locate to prevent vehicles entering.
- Set out bollards as per the guidelines on the next page.

Product/ Material

- Prospect bollard
 - Hot-dip galvanised steel
 - Surface fixing to concrete, and subsurface fixing in all other conditions
- Prospect folding bollard
 - Hot-dip galvanised steel
 - Surface fixing

Supplier

Botton+Gardiner

Address: 53-55 Whiting Street Artarmon NSW 2064

Phone: 1300 762 701

Web: <https://www.bottongardiner.com.au/>

Construction Notes

- Install furniture as per manufacturers' recommendations.
- Ensure the bollards are installed plumb and level and in a constant alignment.

Bollard (General) - Parklands



Sample - Fixed bollard - parklands

Sample - Folding bollard - parklands

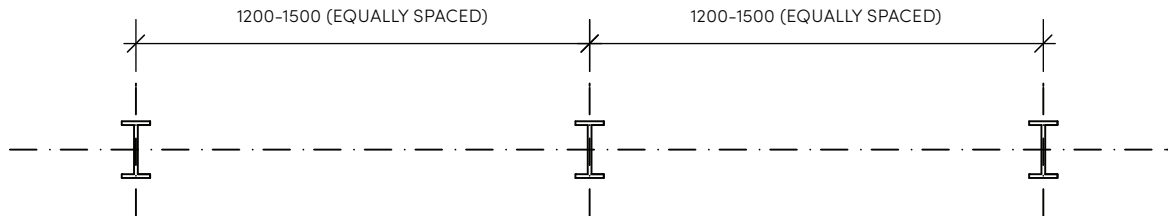

PLAN - TYPICAL ARRANGEMENT 1:20

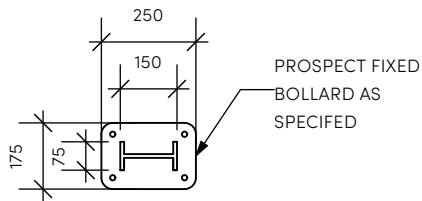

PLAN - FIXED BOLLARD 1:20

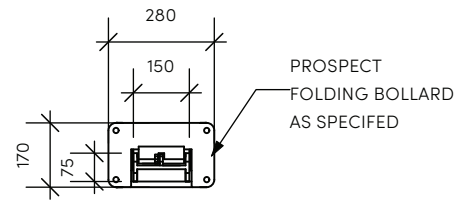

PLAN - FOLDING BOLLARD 1:20

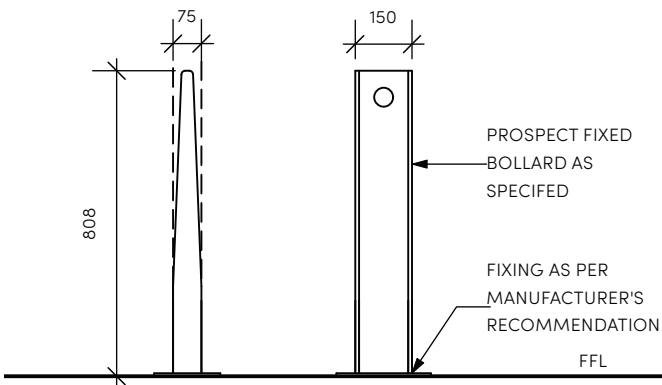

SIDE ELEVATION - FIXED BOLLARD 1:20

FRONT ELEVATION - FIXED BOLLARD 1:20

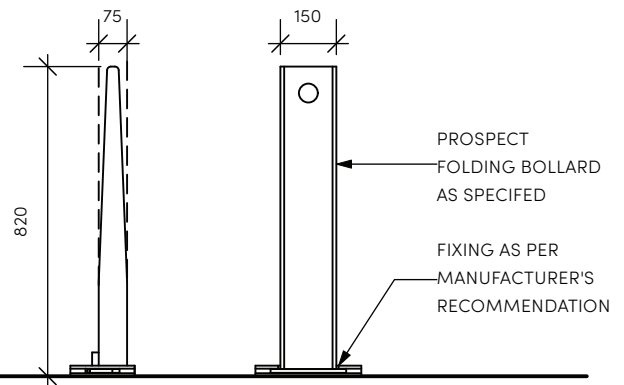

SIDE ELEVATION - FOLDING BOLLARD 1:20

FRONT ELEVATION - FOLDING BOLLARD 1:20

3.2 Furniture

3.2.4 Furniture Guidelines

Application

- Parklands – shared path or bike path
- Locate to prevent vehicles entering.
- Set out bollard as per the guidelines in Road Design Part 6A: Pedestrian and Cyclist Paths. (Austroads 2021).

Product/ Material

- Securapost Sentinel 150NB Removable Bollard
- Securapost Sentinel 150NB Fixed Bollard
- Custom bollard (removable and fixed) to meet the requirements in the Guide to Road Design Part 6A: Pedestrian and Cycle Paths (Austroads 2021), refer diagram in the next sheet.
 - powder coat, yellow /red
 - Class 2 reflective tape
 - Subsurface fixing to fixed bollard

Supplier

Leda Security

Phone: 1300 8780 450

Web: <https://www.ledasecurity.com.au>

Construction Notes

- Install furniture as per manufacturers' recommendations.
- Ensure the bollard is installed plumb and level and in a constant alignment.

Bollard (Shared path / Bike Path) – Parklands



Sample - Bike path bollard - parklands

NOTE:
THE ARRANGEMENT SHOULD COMPLY WITH GUIDE
TO ROAD DESIGN PART 6A: PEDESTRIAN AND
CYCLIST PATHS.

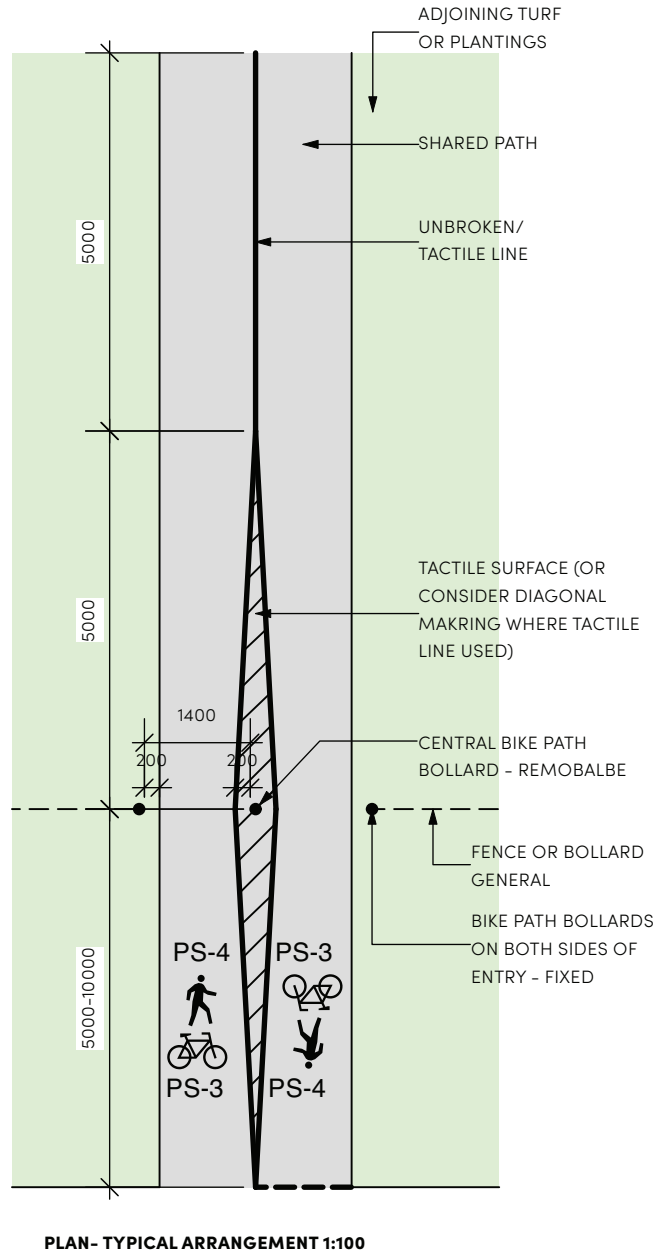
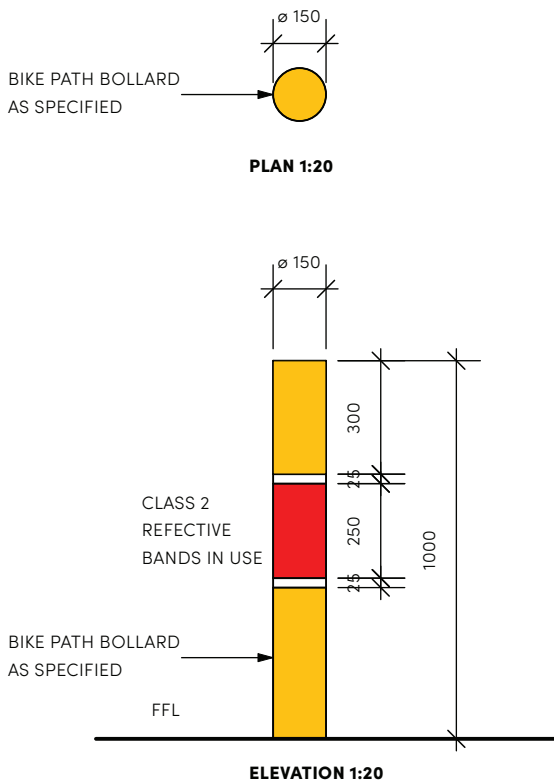

3.2 Furniture

3.2.4 Furniture Guidelines

Application

- Urban Area
 - Pedestrian spaces
 - Civic and High Streets
 - Intersections
 - Urban Parks
- Parklands
 - Major parklands bike paths or shared paths
 - Major and minor Entries
 - Recreation hubs
- The bike rack shall be positioned along cycle routes.
- Set out bike racks as per the guidelines on the next page.

Product/ Material

- Bike Rail (SBR85F/SBR85B)
 - 40NB (50) x 1.5mm Stainless Steel
 - Surface fixing to concrete, and subsurface fixing in all other conditions

Supplier

Leda Security Product Pty Ltd

Address: 8 Ferris St North Parramatta NSW 2151

Phone: 02 8413 3410

Web: <https://www.ledasecurity.com.au>

Construction Notes

- Install furniture as per manufacturers' recommendations.
- Ensure the bike racks are installed in accordance with AS2890.3:2015 Bicycle parking.
- Ensure the bike racks are installed plumb and level.
- Bike rack is to be used in pairs or in groups.

Bike Racks



Sample - Bike racks

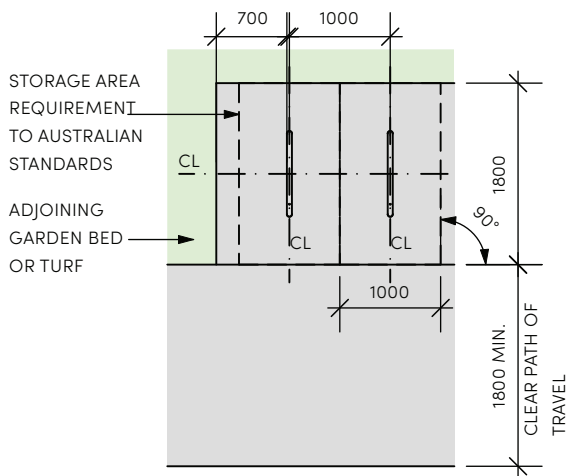

**PLAN - PARK OR PARKLANDS ARRANGEMENT
(90° TO FOOTPATH) 1:75**

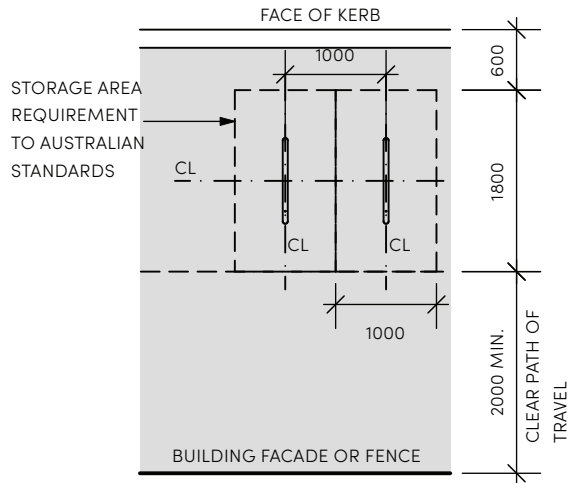

**PLAN - STREET ARRANGEMENT - OPTION 1
90° TO KERB 1:75**

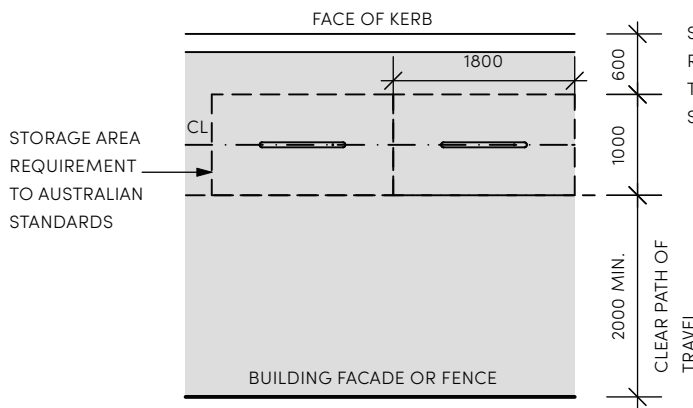

**PLAN - STREET ARRANGEMENT - OPTION 2
ANGLE PARKING OTHER THAN 90° 1:75**

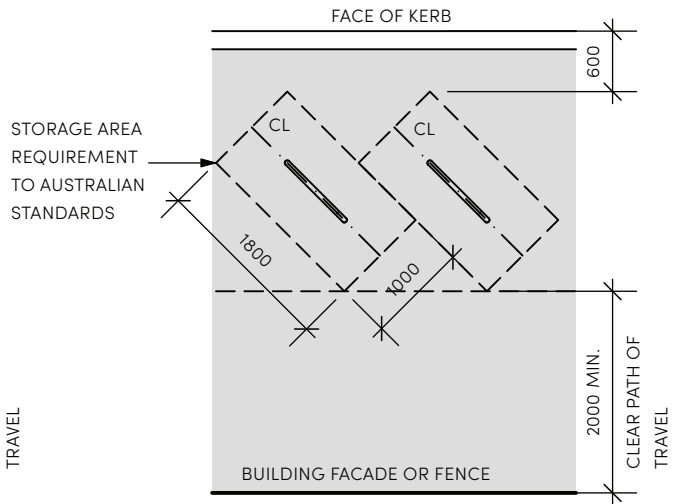

**PLAN - STREET ARRANGEMENT - OPTION 3
PARALLEL TO KERB 1:75**

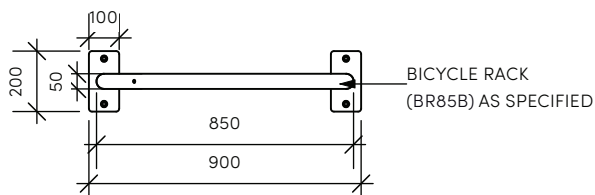

PLAN - SURFACE FIXING TO CONCRETE 1:25

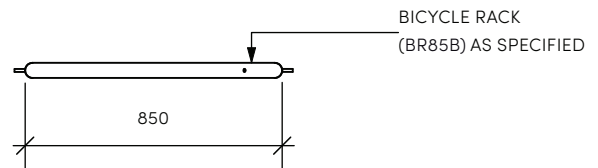

PLAN - SUB SURFACE FIXING TO PAVERS 1:25

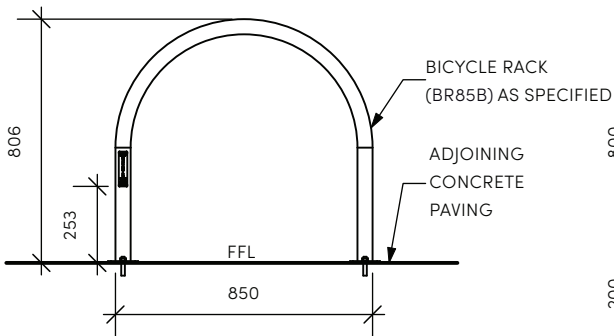

SECTION - SURFACE FIXING TO CONCRETE 1:25

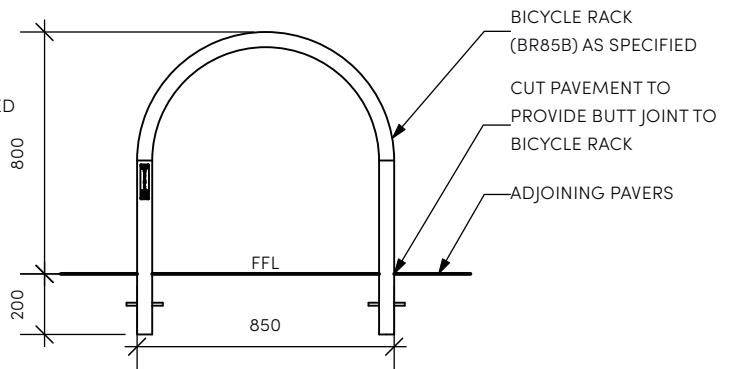

SECTION - SUB SURFACE FIXING TO PAVERS 1:25

3.2 Furniture

3.2.4 Furniture Guidelines

Application

- Urban Area
- Parklands
 - Recreation hubs
- Locate barbecues close to shelters or picnic settings so that the barbecue can be equally shared.
- Wherever possible, locate barbecues in shaded areas.
- Barbecues should be located where they can be easily surveilled to reduce the risk of vandalism.
- Set out barbecue as per the guidelines on the next page.

Product/ Material

- Equal Access Electric BBQ Cabinet Double 2100
 - Stainless Steel
 - Surface fixing
- Smart BBQ Management System to be integrated

Supplier

Greenplate

Address: Unit 2/15 Natasha St Capalaba QLD 4157

Phone: 07 3245 3008

Web: <https://greenplate.com.au/>

Construction Notes

- Install furniture as per manufacturers' recommendations.
- Ensure the barbecue is installed plumb and level.

Barbecue



Sample - Barbecue

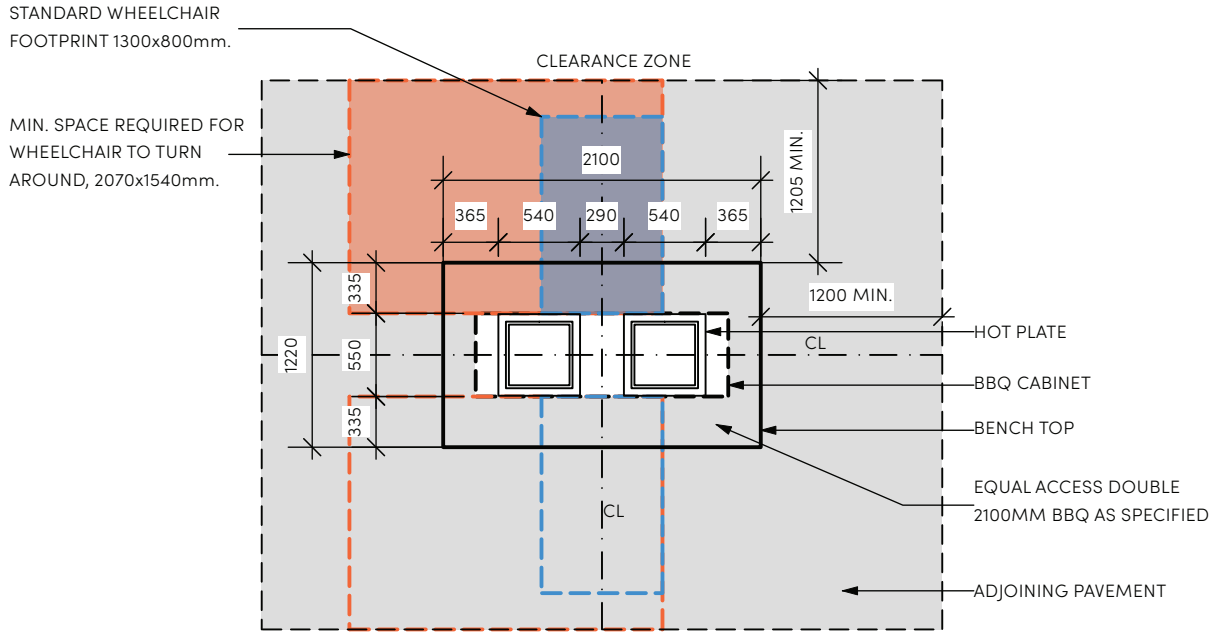

PLAN 1:50

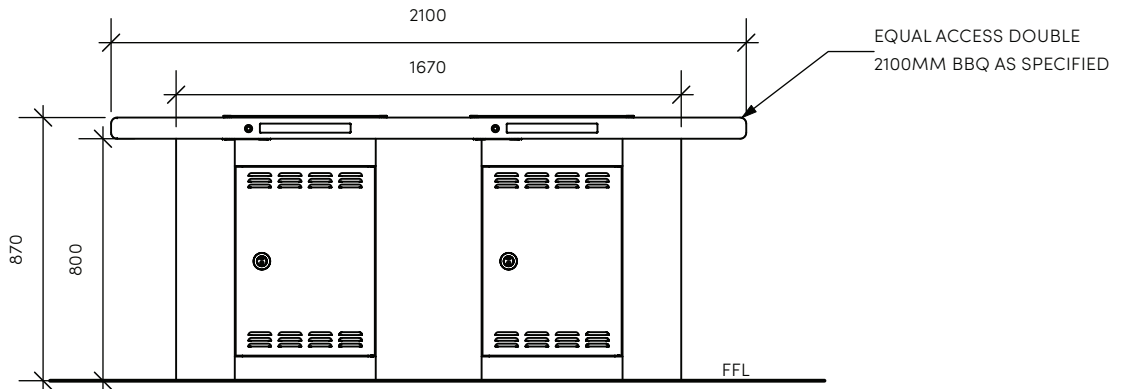

FRONT ELEVATION 1:25

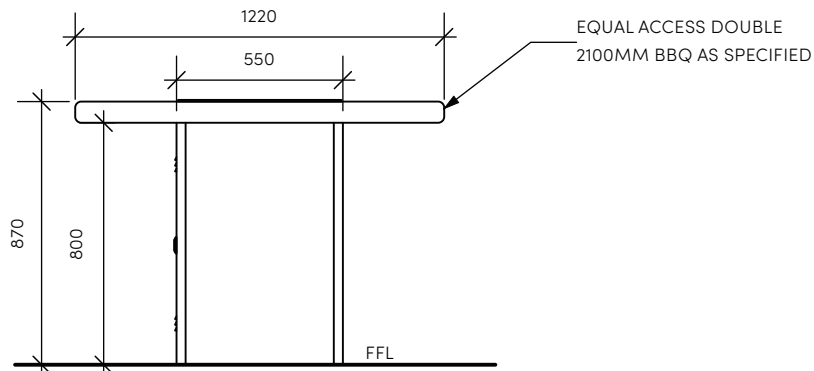

SIDE ELEVATION 1:25

3.2 Furniture

3.2.4 Furniture Guidelines

Application

- Urban Area
 - Pedestrian Spaces
- Where there is heavy pedestrian traffic or a need to optimize flexible space for large events.

Product/ Material

- Invisigrate Paver Support Tree Grate
 - Grade 304 Stainless Steel to plate and frame
 - The 1500 square model is the preferred size, while the 1200 square model may be used where site constraints exist
 - Growth cushion and centre infill ring (Optional), to be confirmed with Sydney Olympic Park Authority

Supplier

Citygreen

Address: L6 10 Herb Elliott Ave Sydney Olympic Park
NSW 2127

Phone: 1300 066 949

Web: <https://citygreen.com//>

Construction Notes

- Install furniture as per manufacturers' recommendations.
- Ensure tree grate to be flush with adjoining pavement.
- Set concrete surround below pavement.
- Paver infill should match the joining pavement. Cut pavers if required to suit the depth of the tree grate.

Tree Grate



Sample - Tree grate

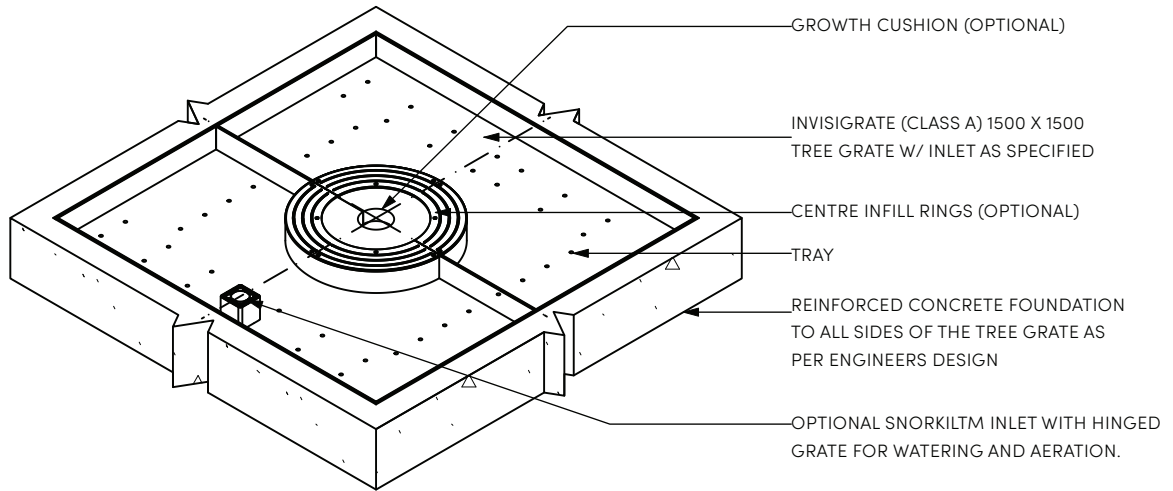

3D VIEW

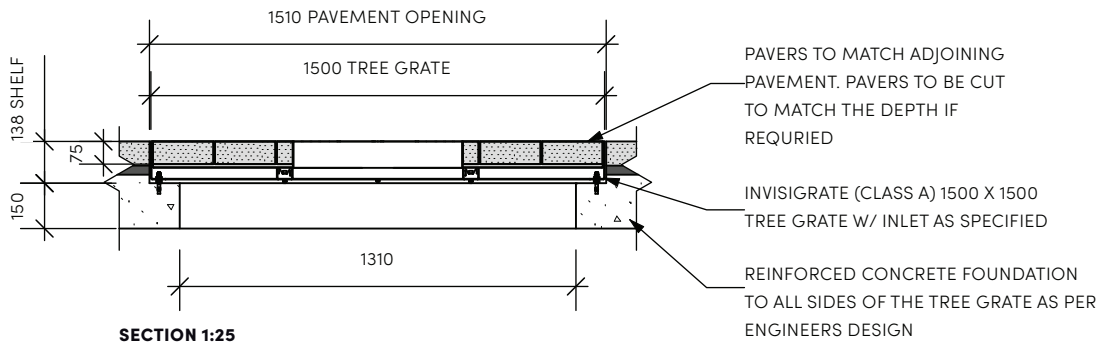

SECTION 1:25

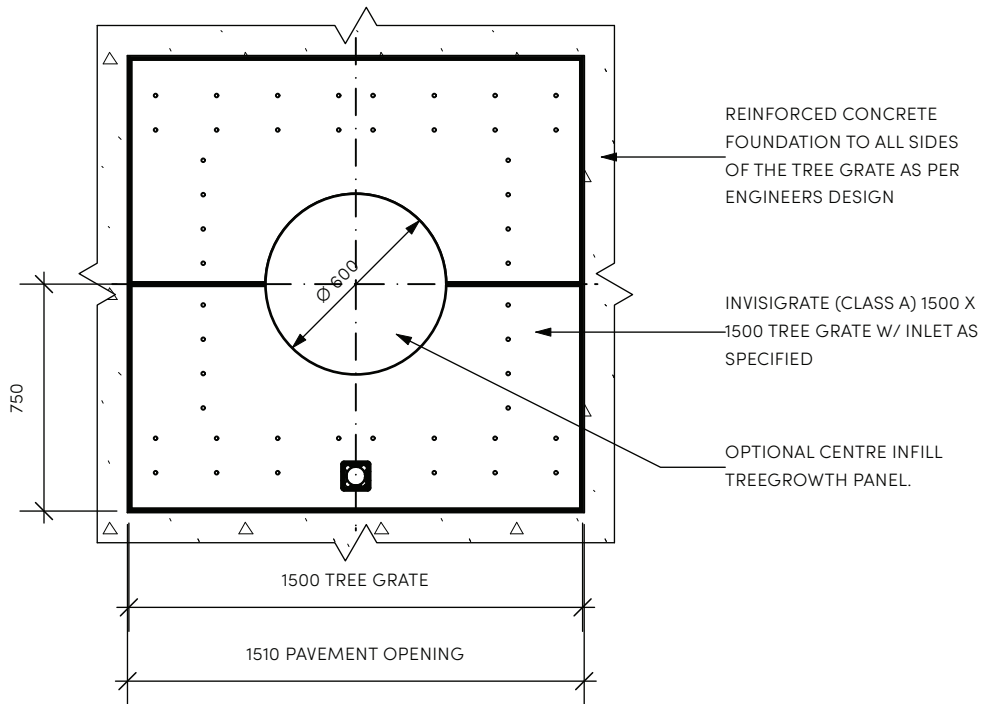

PLAN 1:25

3.2 Furniture

3.2.4 Furniture Guidelines

Application

- Urban area
- Parklands

Product/ Material

- Piatto chair (PC7)
 - 600W x 600L x 795H (1 seater)
 - Free standing
 - 2 End arms
 - Battens: Aluminum Powder Coated, multicolour
 - Frame: Aluminum Powder Coated, Textura Woodland grey

Supplier

Street Furniture Australia

Address: N6 Regents Park Estate, 391 Park Road
Regents Park NSW 2143

Phone: 02 8774 8888

Web: <https://streetfurniture.com/>

Construction Notes

- Install furniture as per manufacturers' recommendations.

Movable Chair



Sample - Movable chair

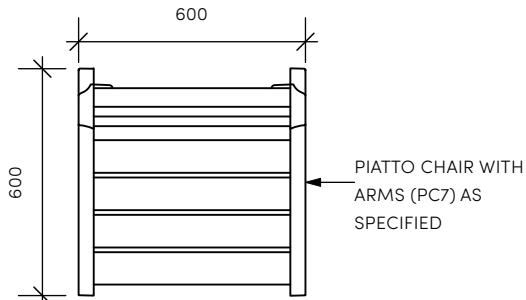

PLAN 1:20

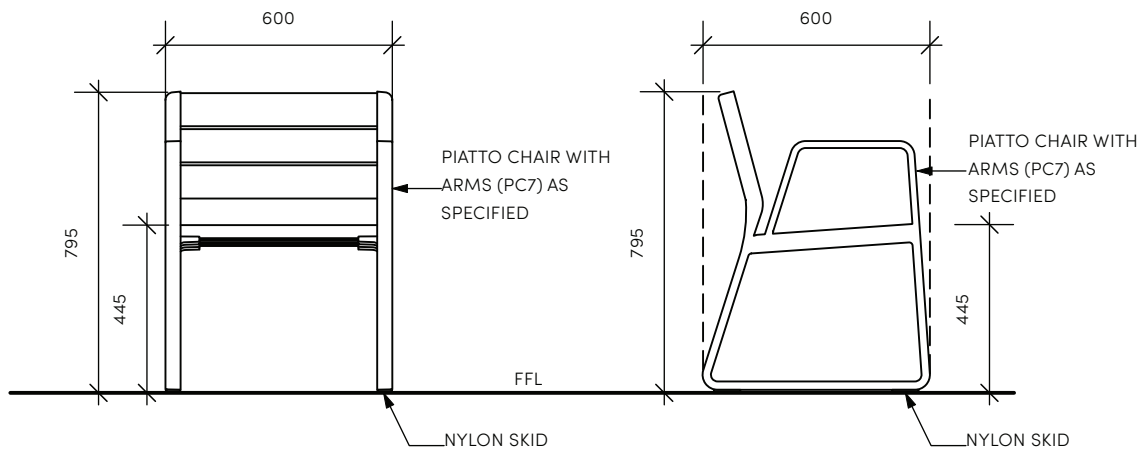

FRONT ELEVATION 1:20

SIDE ELEVATION 1:20

3.2 Furniture

3.2.4 Furniture Guidelines

Application

- Urban area
- Parklands

Product/ Material

- Jumbo Park Setting (FELJPS)
 - Overall: 2760L x 1860W x 758H
 - Table: 1808L x 1031W x 758H
 - Bench: 1808L x 260W x 448H
 - Aluminum top
 - End cap colour to be approved by the Authority

Supplier

Felton

Address: 5 Millenium Court
Silberwater NSW 2118

Phone: 1800 834 016

Web: <https://felton.net.au>

Construction Notes

- Install furniture as per manufacturers' recommendations.

Movable Picnic Table Set



Sample - Movable picnic table set

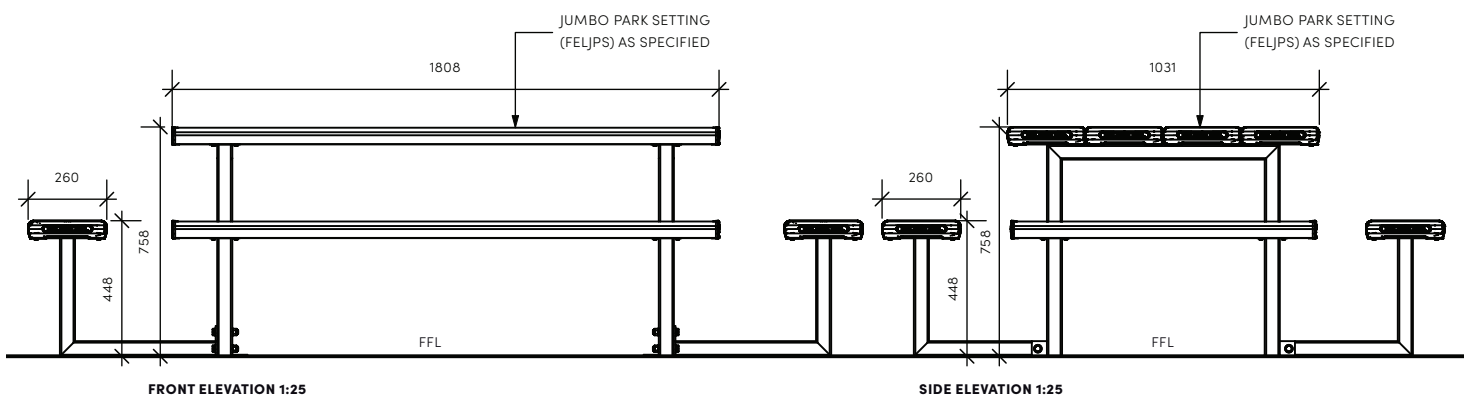
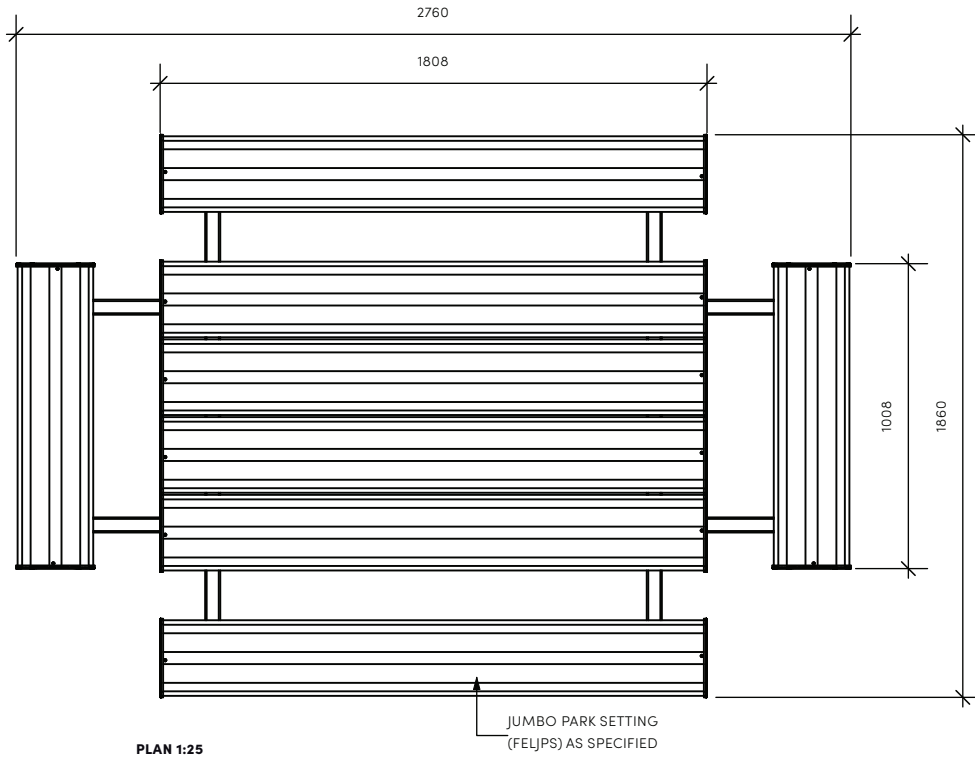

3.2 Furniture

3.2.4 Furniture Guidelines

Application

- Urban Area - in particular the Stadia Precinct and Sports and Civic Precinct.
- Locate to prevent vehicles entering
- Set out planter as per the guidelines on the next page

Product/ Material

- In Ground Planter
 - Stainless steel finish
 - Subsurface fixing
 - Customisation options to be confirmed with Sydney Olympic Park Authority

Supplier

Ezi Security System

Address: 11 Cooper St Smithfield NSW 2164

Phone: 1300 558 304

Web: <https://www.ezisecurity.com.au/>

Construction Notes

- Install furniture as per manufacturers' recommendations.
- Ensure the planters are installed plumb and level and in a constant alignment.

Fixed Above-ground Planter



Sample - Fixed Above-ground Planter

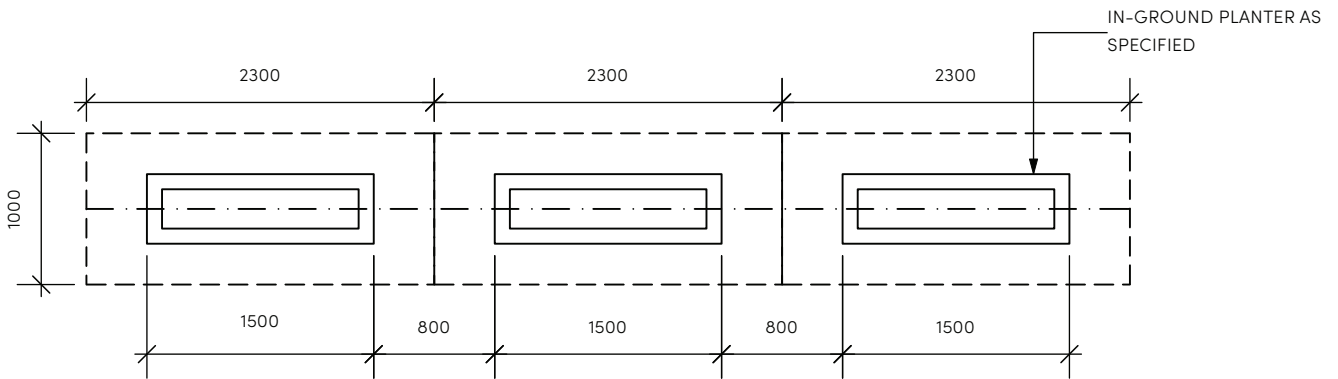

PLAN- TYPICAL ARRANGEMENT 1:50

NOTE:

- SAFETYFLEX UNIVERSAL PLANTER-40. THIS PLANTER HAS BEEN DESIGNED TO BE BESPOKE PLANTER TO BE DESIGNED TO ANY SIZE REQUIRED BEING A MINIMUM WIDTH OF 1500 TO A MAXIMUM WIDTH AS REQUIRED TO BE A MINIMUM DEPTH OF 450 TO A MAXIMUM DEPTH AS REQUIRED
- PLANTER POSTS CAN TAKE MULTIPLE SIZES OF BOX: DEEPER OR SHALLOWER

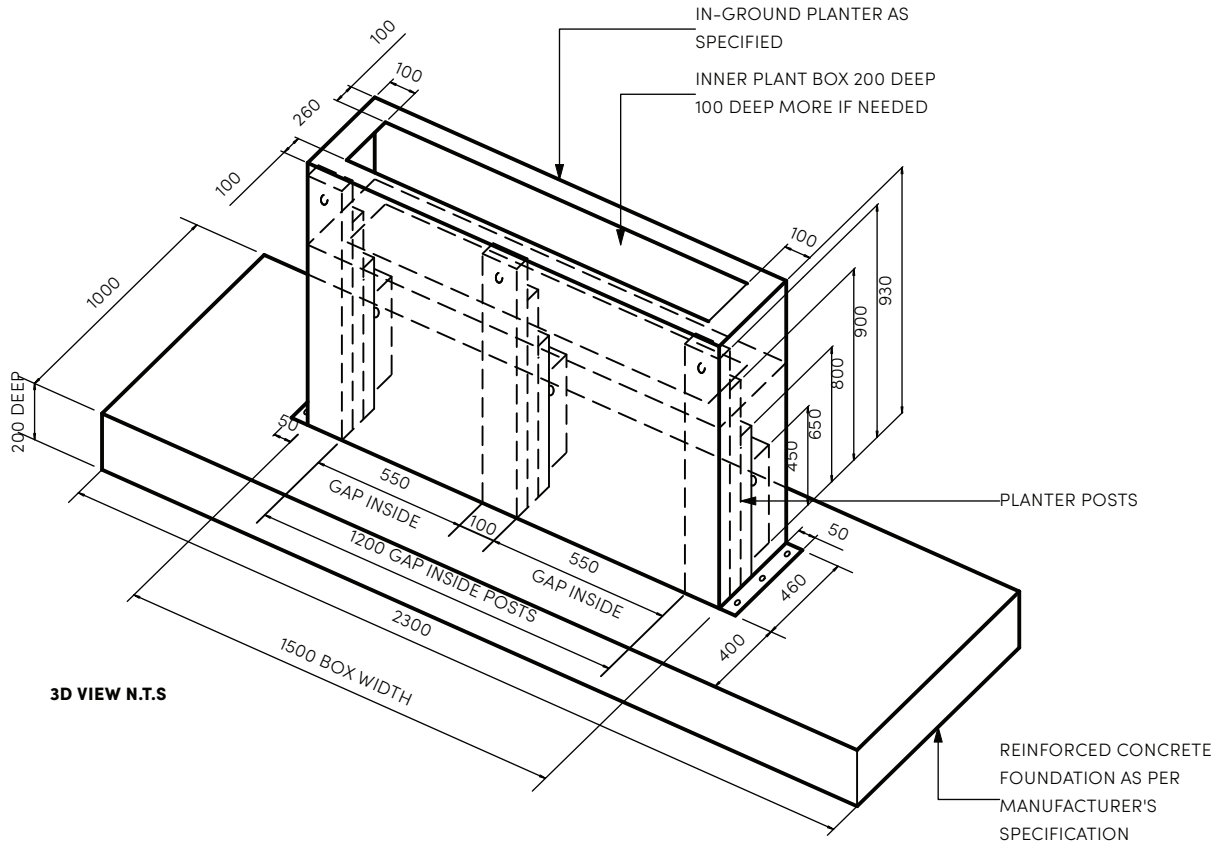

3D VIEW N.T.S

3.2 Furniture

3.2.4 Furniture Guidelines

Application

- Urban Area - as advised by Sydney Olympic Park Authority

Product/ Material

- Mild steel hot dip galvanised

Supplier

As approved by the Authority

Construction Notes

- To comply with BCA and relevant Australian Standards requirements.
- Assembled from readily available sample components.
- Sub-surface mounted in concrete footing.
- Setout of posts to be based on as-built dimensions of fixing points and adjoining elements.
- Shop drawings may be required for Sydney Olympic Park Authority's approval prior to commencement of works.
- Structural engineer's review and certification will be required during all stages of design and installation.

Palisade Fence Type 1A - 1.1m High



Sample - Palisade fence - 1.1m high

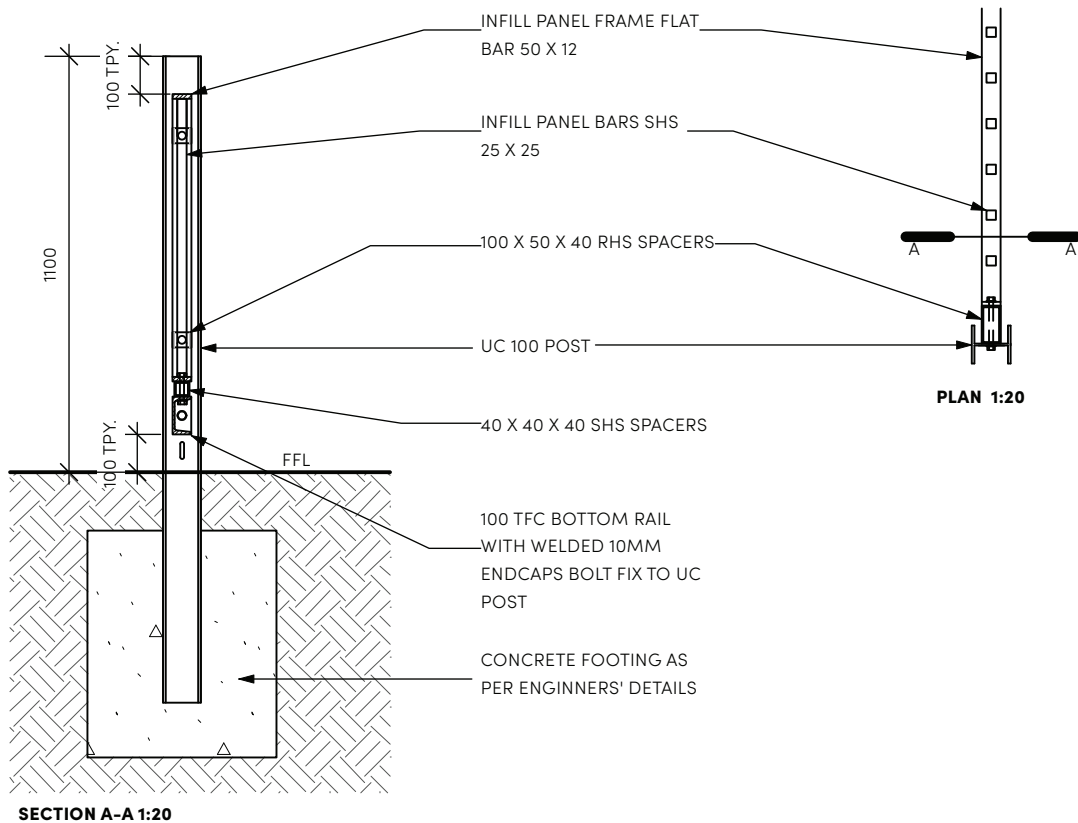
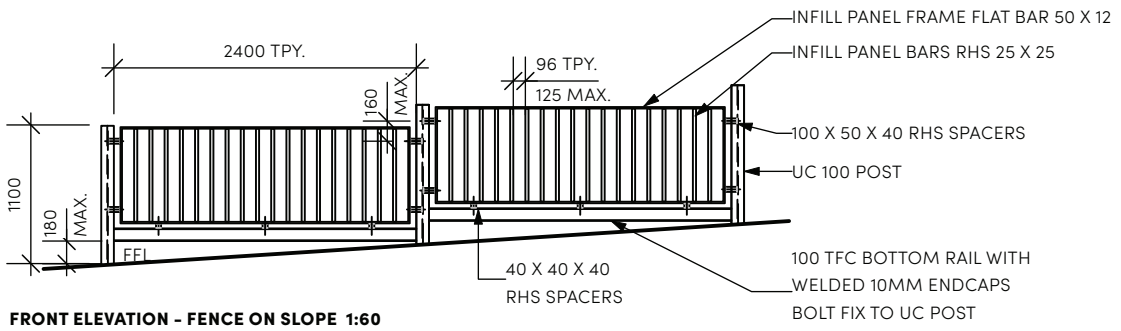
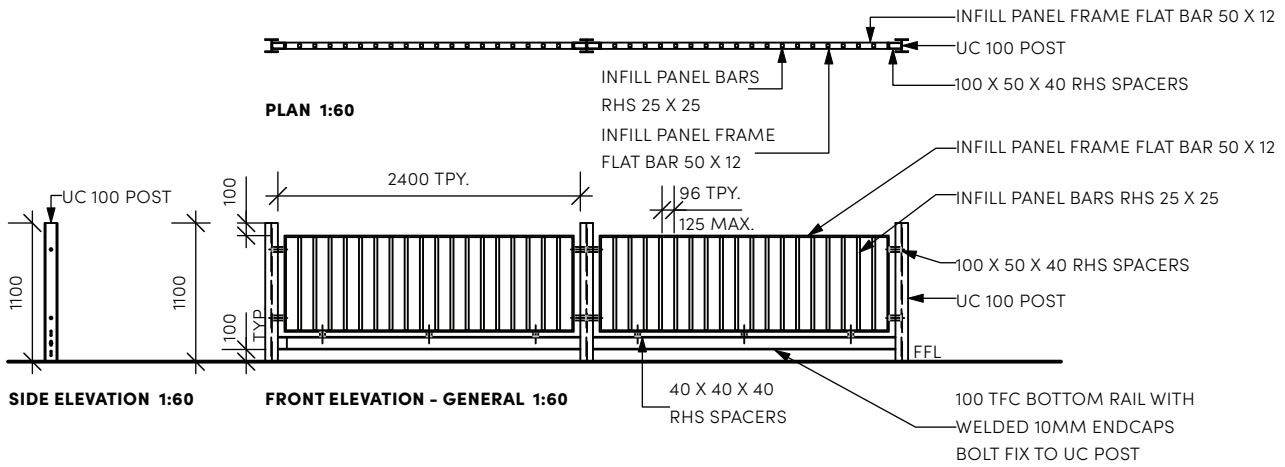

3.2 Furniture

3.2.4 Furniture Guidelines

Application

- Urban Area - as advised by Sydney Olympic Park Authority

Product/ Material

- Mild steel hot dip galvanised.

Supplier

As approved by the Authority

Construction Notes

- To comply with BCA and relevant Australian Standards requirements.
- Assembled from readily available sample components.
- Sub-surface mounted in concrete footing
- Setout of posts to be based on as-built dimensions of fixing points and adjoining elements.
- Shop drawings may be required for Sydney Olympic Park Authority's approval prior to commencement of works.
- Structural engineer's review and certification will be required during all stages of design and installation.

Palisade Fence Type 1B - 1.9m High



Sample - Palisade fence - 1.9m high

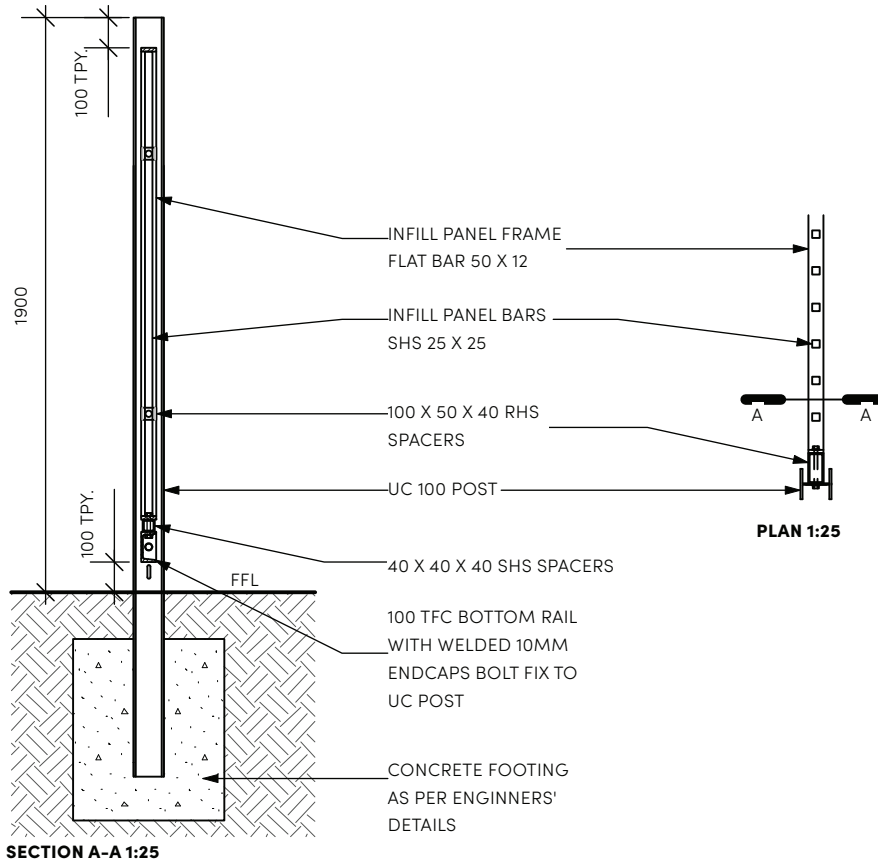
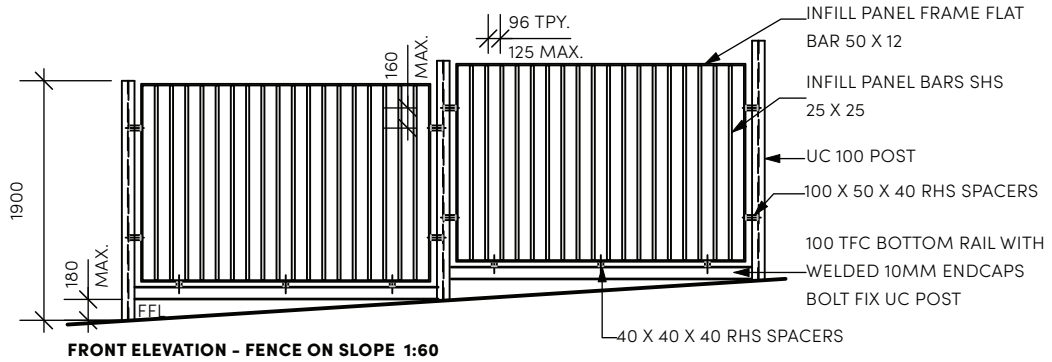
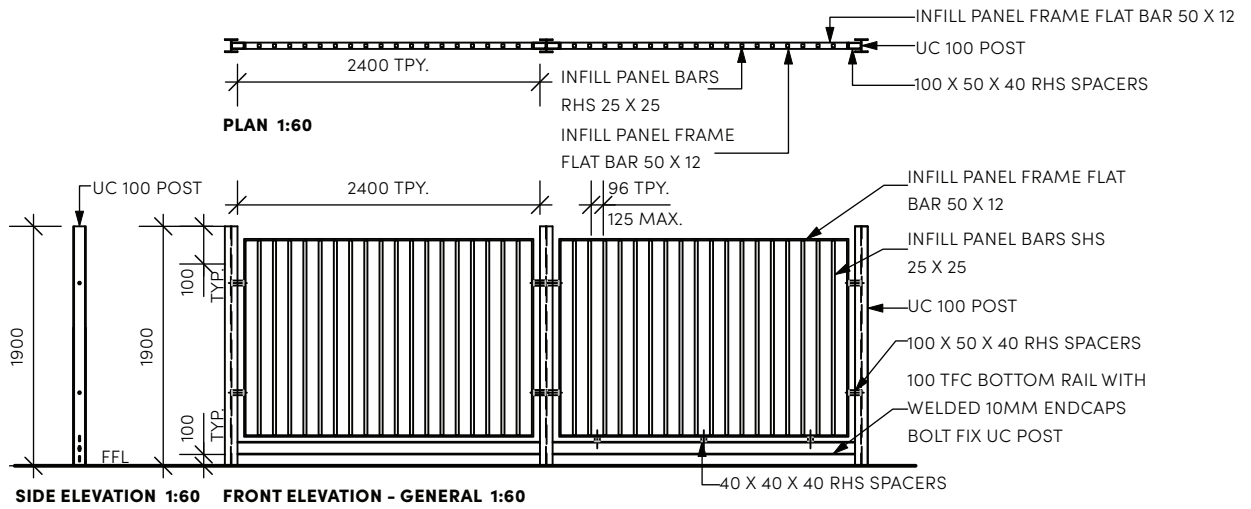

3.2 Furniture

3.2.4 Furniture Guidelines

Application

- Urban Area - as advised by Sydney Olympic Park Authority
- Parklands - as advised by Sydney Olympic Park Authority

Product/ Material

- Mild steel hot dip galvanised.

Supplier

As approved by the Authority

Construction Notes

- To comply with BCA and relevant Australian Standards requirements.
- Assembled from readily available sample components.
- Surface fixing to wall or into concrete footing
Setout of posts to be based on as-built dimensions of fixing points and adjoining elements.
- Shop drawings may be required for Sydney Olympic Park Authority's approval prior to commencement of works.
- Structural engineer's review and certification will be required during all stages of design and installation.

Palisade Fence Type 2 - 1.8m High



Sample - Palisade fence - 1.8m high

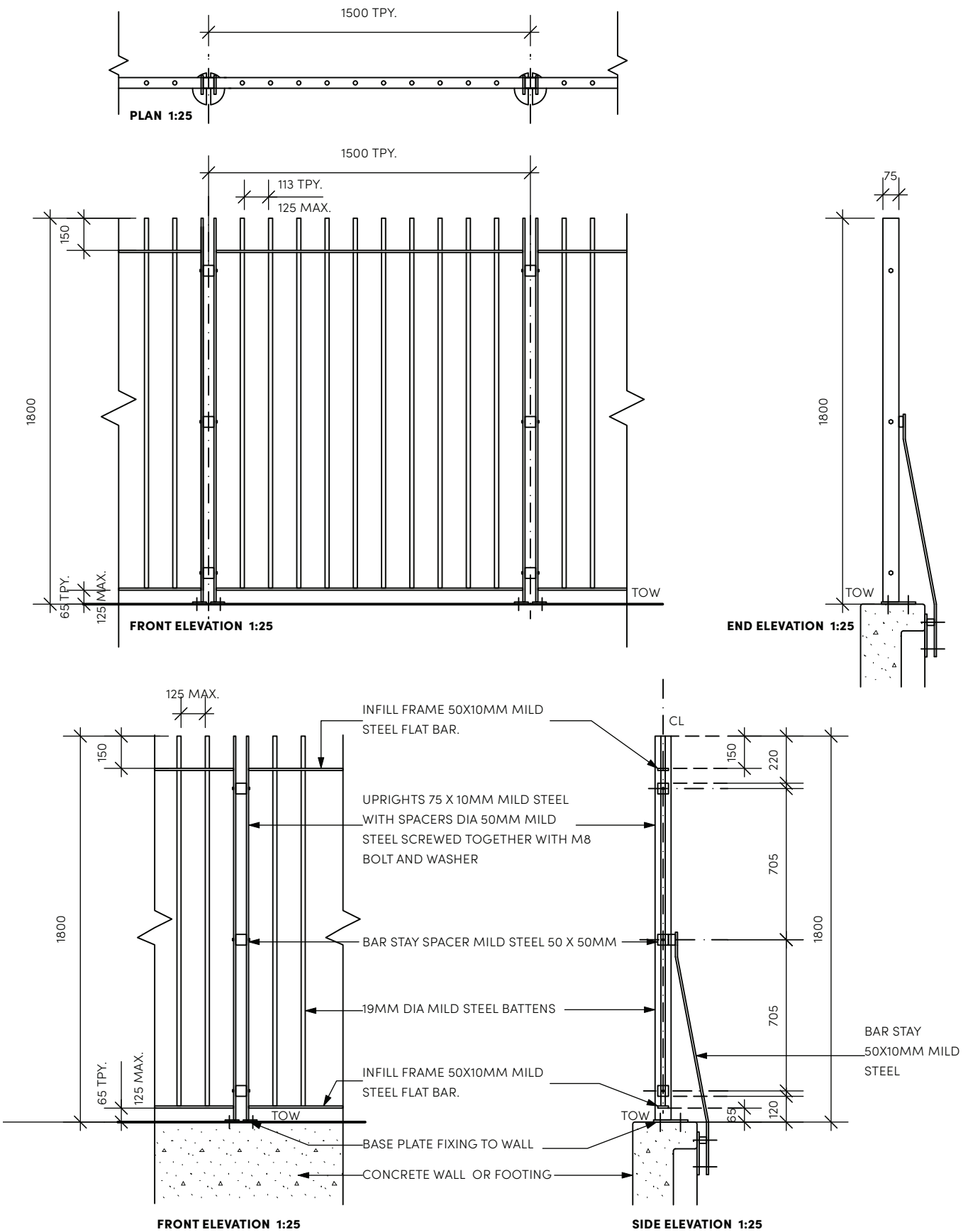

3.2 Furniture

3.2.4 Furniture Guidelines

Application

- Urban Area - as advised by Sydney Olympic Park Authority
- Parklands - as advised by Sydney Olympic Park Authority

Product/ Material

- Mild steel hot dip galvanised.

Supplier

As approved by the Authority

Construction Notes

- To comply with BCA and relevant Australian Standards requirements.
- Assembled from readily available sample components.
- Surface fixing into concrete footing
- Setout of posts to be based on as-built dimensions of fixing points and adjoining elements.
- Shop drawings may be required for Sydney Olympic Park Authority's approval prior to commencement of works.
- Structural engineer's review and certification will be required during all stages of design and installation.

Palisade Fence Type 2 - Vehicle Gate



Sample - Palisade fence vehicle gate

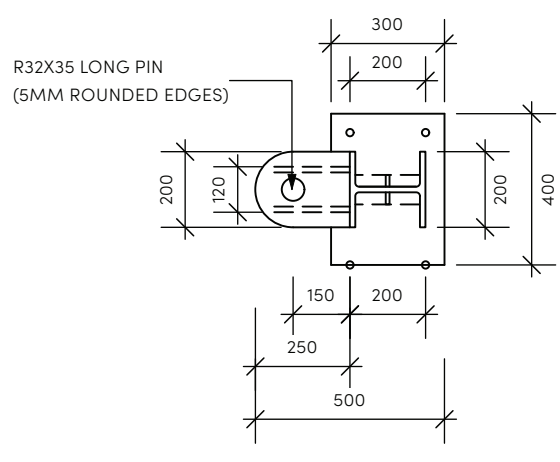
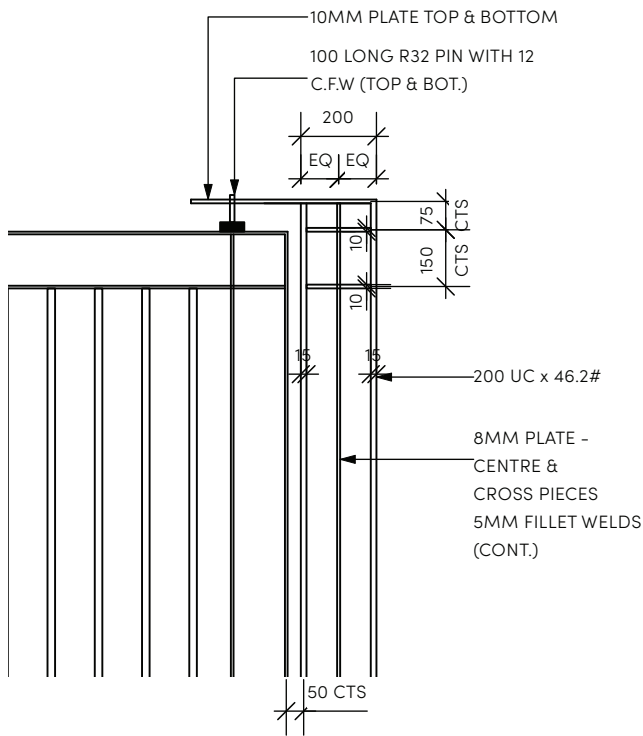
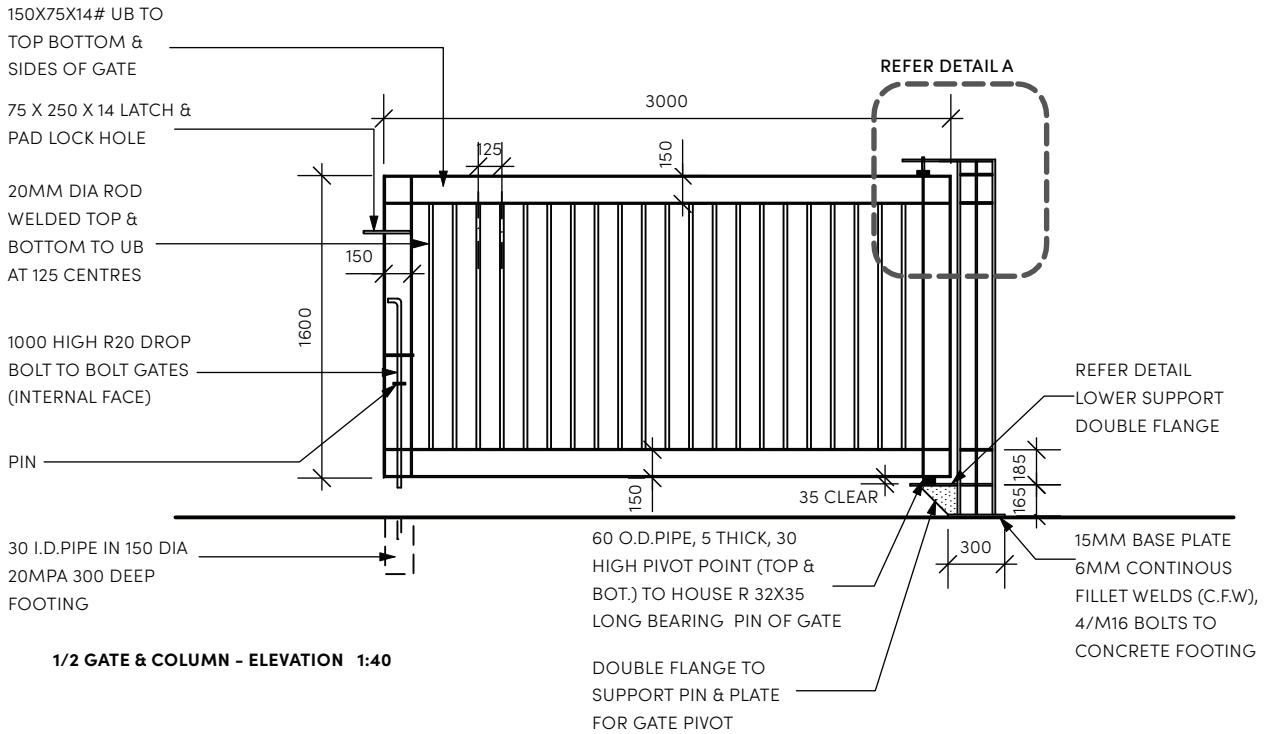

3.2 Furniture

REFER ALSO SHEETS F23-3/4

3.2.4 Furniture Guidelines

Application

- Parklands - as advised by Sydney Olympic Park Authority

Product/ Material

- 1200mm high wire ringlock fence with shade-cloth cover
 - Strainer post footings: 20MPa concrete, 225 x min. 800mm deep
 - Start pickets: 1800mm long black steel star picket at max. 3000 cts.
 - Fencing wire: 2.8mm galvanised high tensile fencing wire
 - Ringlock fencing: Rignlock steel mesh fencing with 300mm wide openings
 - Shade cloth: 75-80% density black shade cloth
 - equal or similar to Hortshade Heavy Knitted Shade Cloth

Supplier

As approved by the Authority

Construction Notes

- Assembled from readily available sample components.
- Subsurface fixing into concrete footing
- Setout of posts to be based on as-built dimensions of fixing points and adjoining elements.
- Shop drawings may be required for Sydney Olympic Park Authority's approval prior to commencement of works.
- Structural engineer's review and certification will be required during all stages of design and installation.
- Confirm with Sydney Olympic Park Authority on the Frog Fence works specification.

Permanent Frog Fence



Sample - Permanent Frog fence



Sample - Frog fence gate

TIE WIRE POINTS GENERALLY AT 600 INTERVALS WITH EXCEPTION OF CLOSE TO THE 2 X TOP WIRES (SAME LEVEL) & HOOK WIRE AT 300 DIA (NOT SHOWN)

TIE WIRE WITHIN 100 OF STAR PICKET EITHER SIDE

STAR PICKET

SHADE CLOTH

LINE OF SHADE CLOTH OVER FENCE WIRE. NOTE THAT, HORIZONTAL LINE WITH ONLY MINOR PROTRUSIONS TO THE LINE OF THE SHADE CLOTH ABOVE THE POSTS

RINGLOCK FENCING

PERMANENT WIRE STRAINER

STRAINER POST

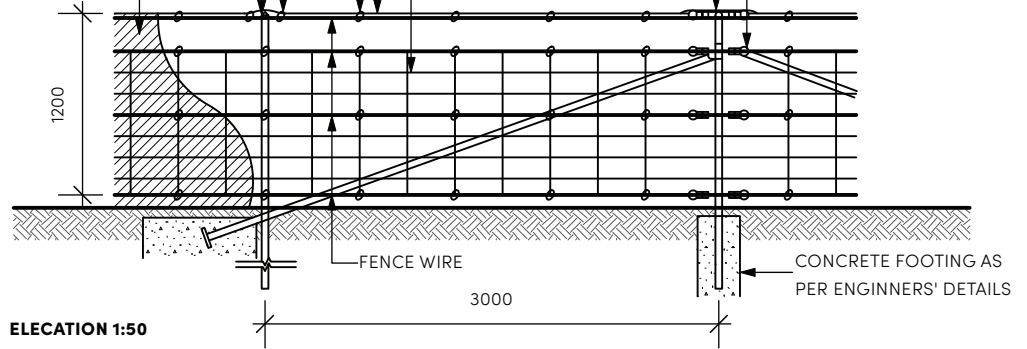

ELECACTION 1:50

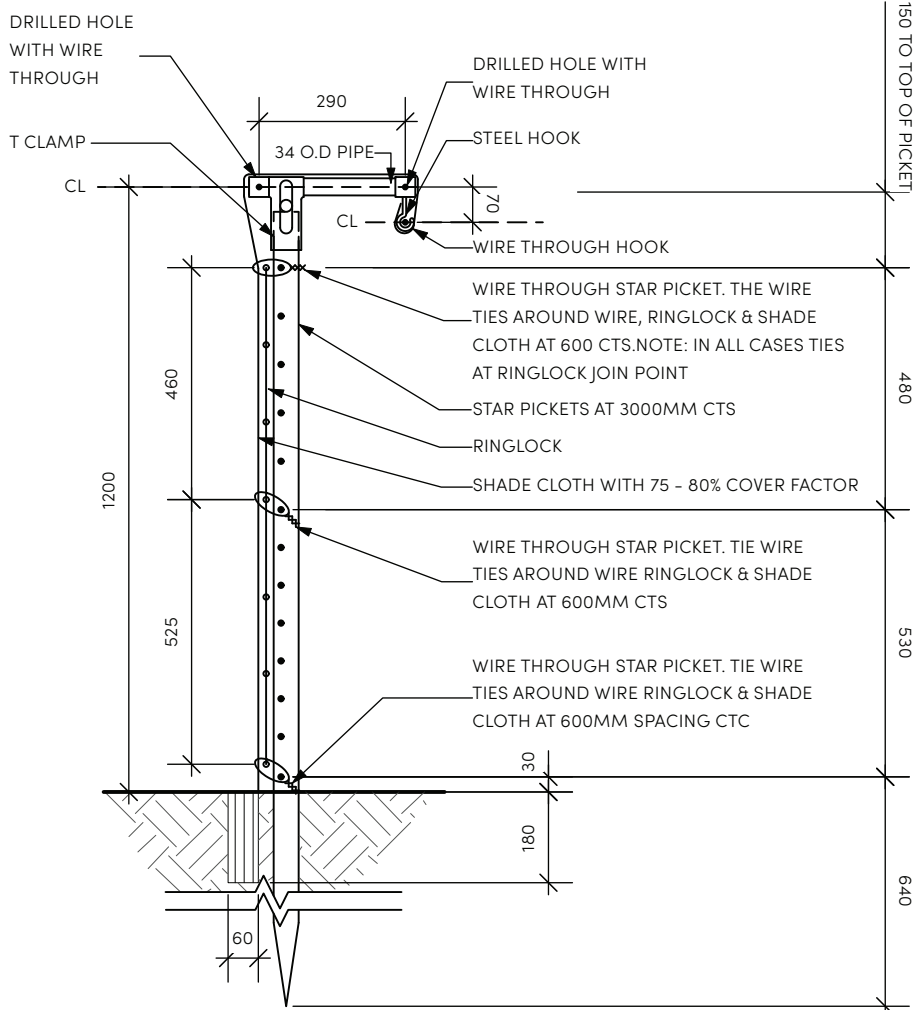

ELECACTION 1:15

REFER ALSO SHEETS F23-1/2

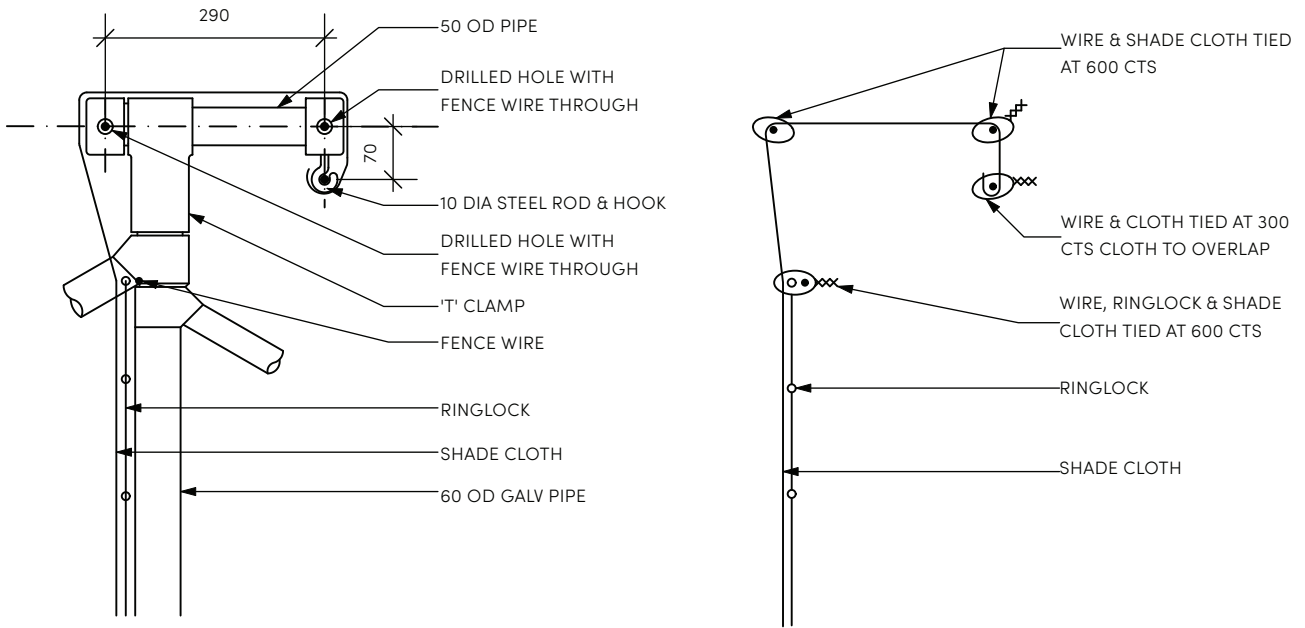

TYPICAL DETAIL OF STRAINER POSTS & BETWEEN POSTS 1:10

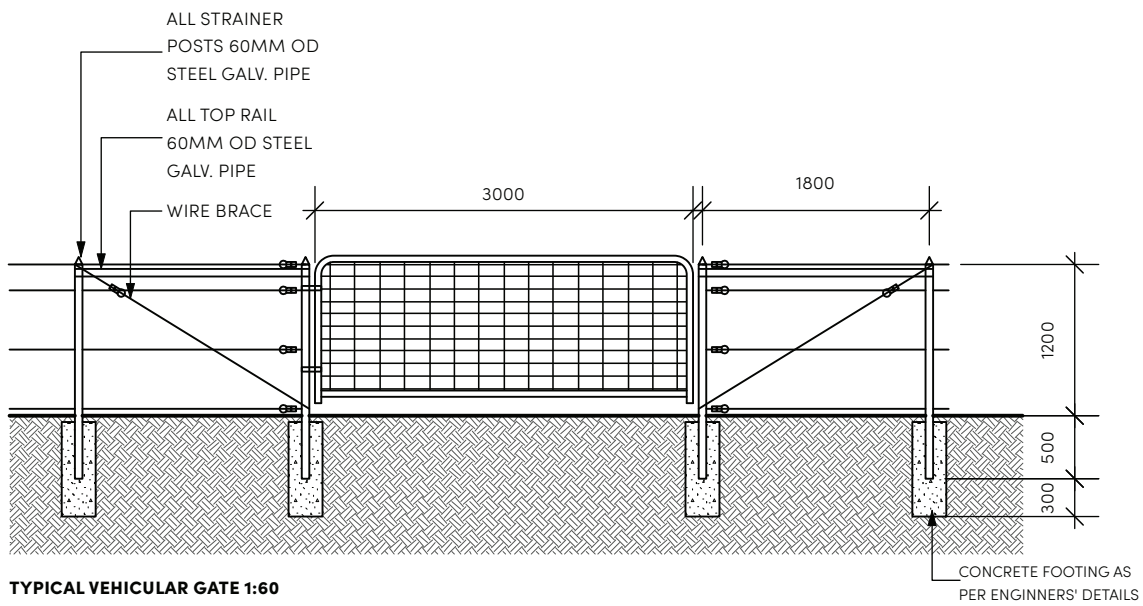

TYPICAL VEHICULAR GATE 1:60

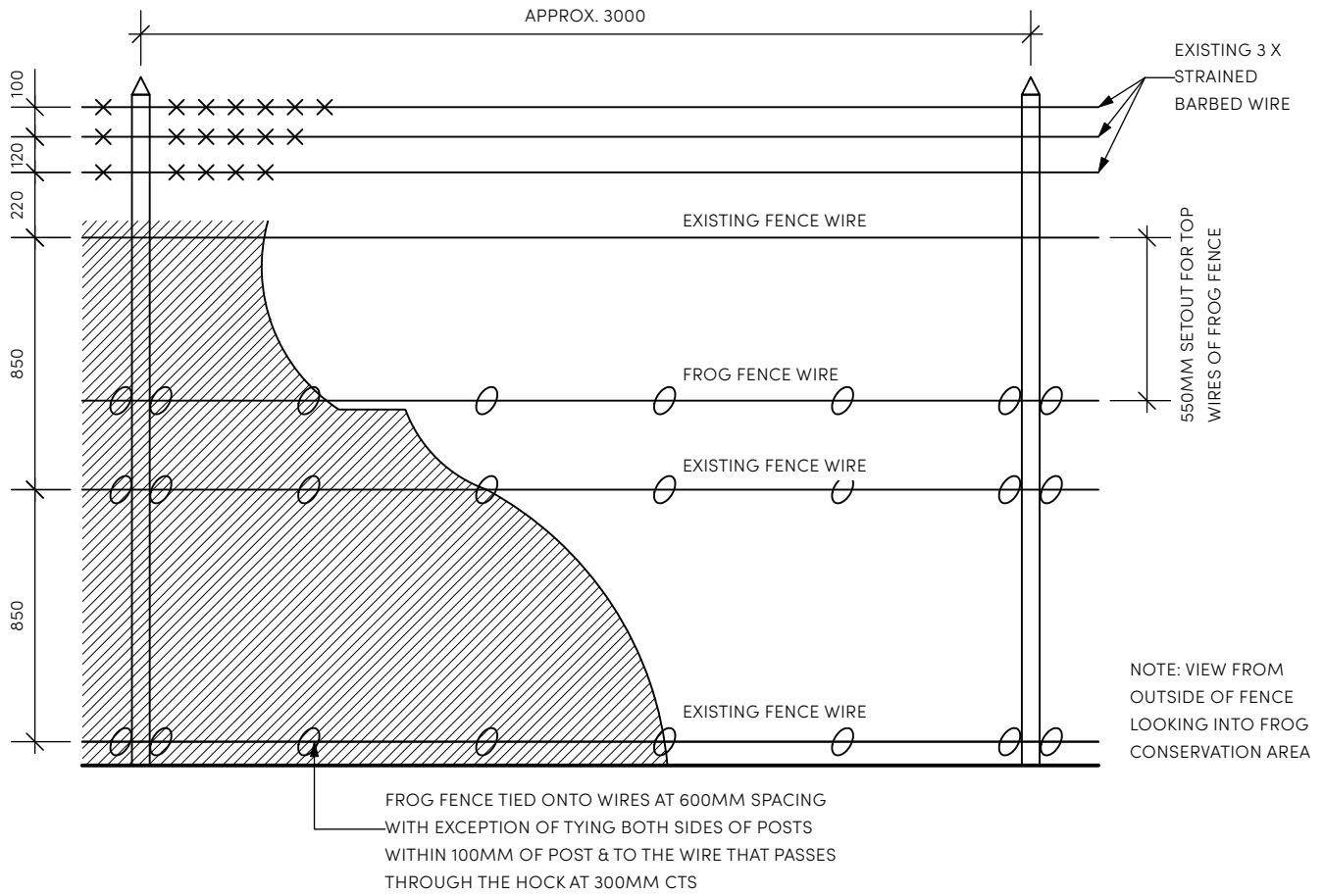

FROG FENCE ATTACHED TO SECURITY FENCE SECTION 1:25

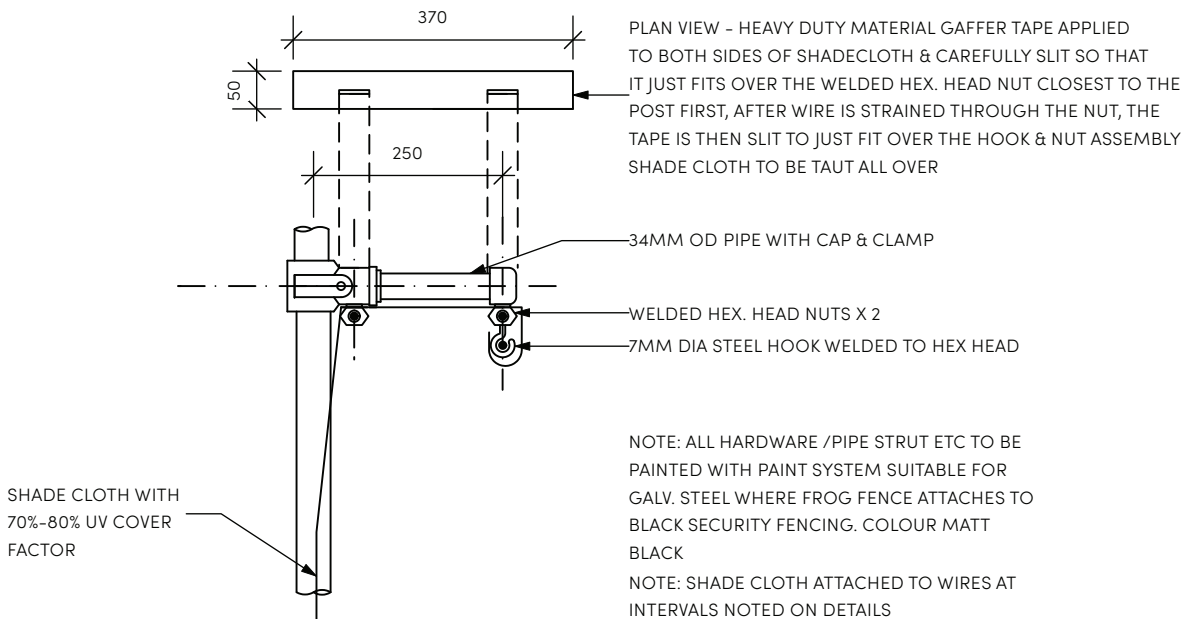

SECTION 1:10

3.2 Furniture

3.2.4 Furniture Guidelines

Application

- Parklands - as advised by Sydney Olympic Park Authority
- Locate to prevent vehicles entering.

Product/ Material

- 500W x 500H x 1000L grade 'A' finish saw cut sandstone block

Supplier

As approved by the Authority

Construction Notes

- Confirm setout and spacing with Sydney Olympic Park Authority prior to fixing stones in place.

Vehicle Barrier



Sample - Sandstone vehicle barrier

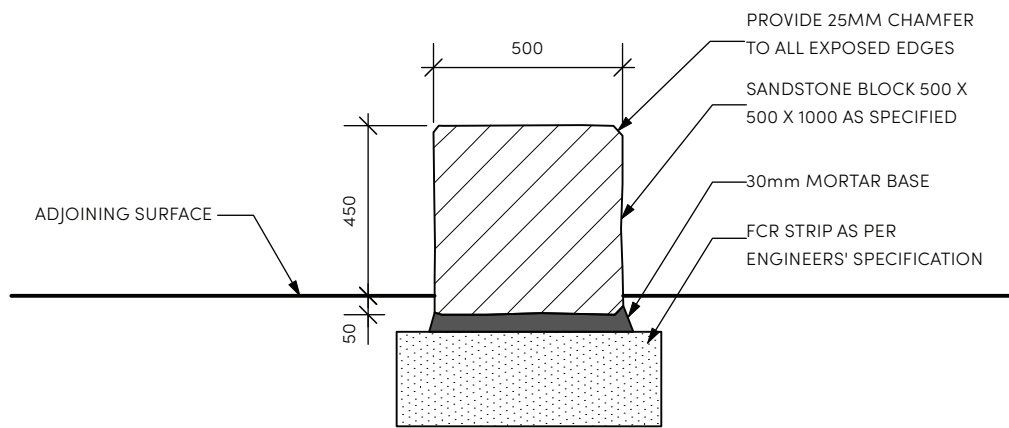

SECTION 1:20

3.2 Furniture

3.2.4 Furniture Guidelines

Application

- Urban Area
- Wall-mounted handrails are provided on both sides of the stairs and the ramp (with a 1:14 gradient) where adjacent to walls, ensuring safe pedestrian access across level changes.

Product/ Material

- 316 grade stainless steel

Supplier

As approved by the Authority

Construction Notes

- Handrail To comply with AS 1428
- Assembled from readily available sample components.
- Surface mounted to wall with stainless steel fixing. Provide fixing details for Sydney Olympic Park Authority's approval prior to commencement of works.
- Structural engineer's review and certification will be required during all stages of design and installation.

Also refer to this manual:

- Section 3.1 PL16 for tactile ground surface indicators

Handrail - Wall Mounted



Sample - Handrail - wall mounted

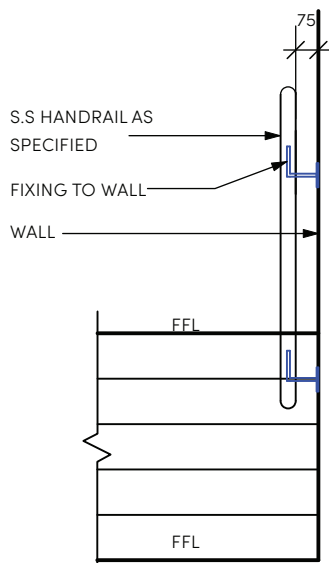
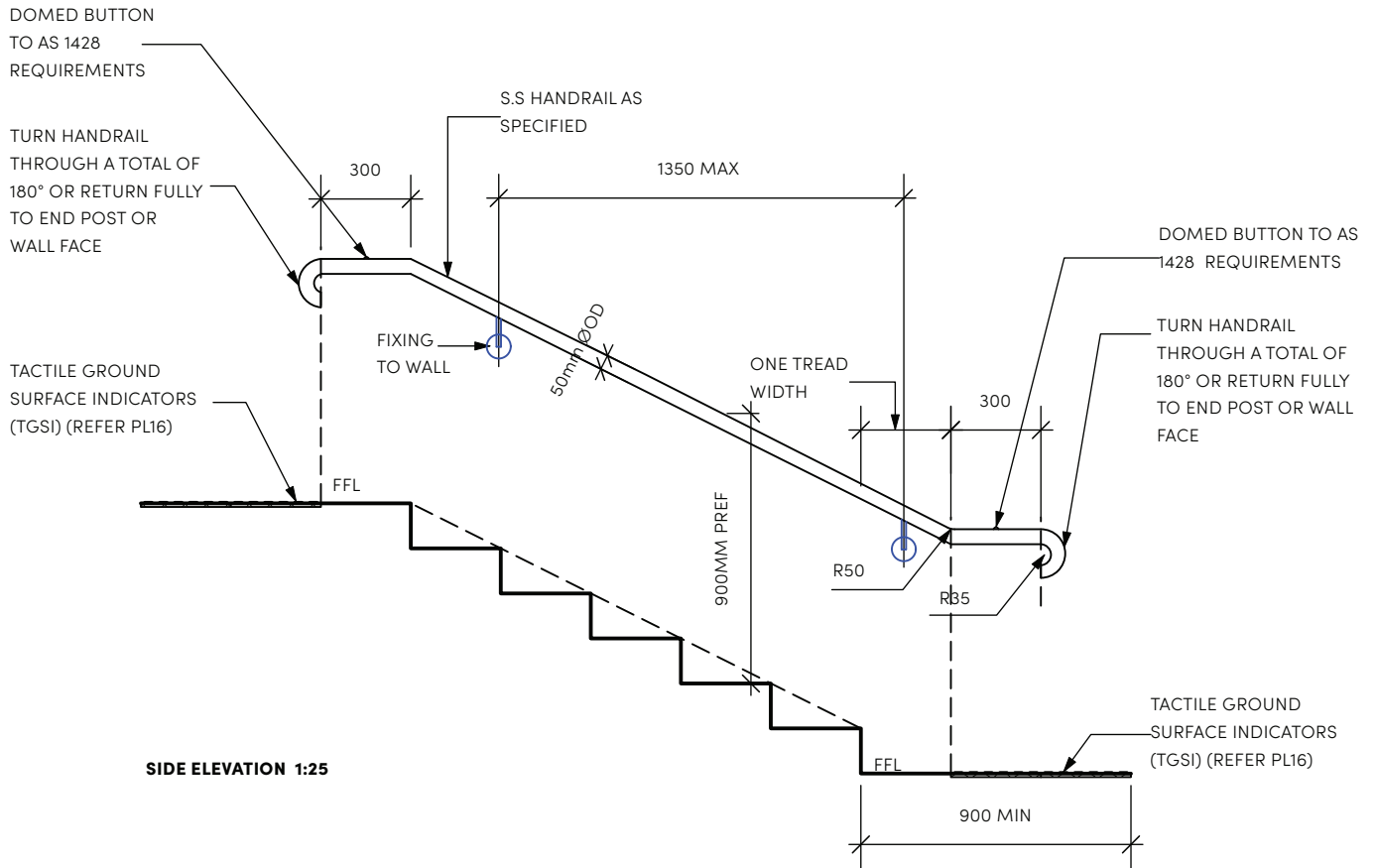

3.2 Furniture

3.2.4 Furniture Guidelines

Application

- Urban Area
- Full open free standing handrails are provided on both sides of the stairs and the ramp (with a 1:14 gradient) where level changes less than 1m, ensuring safe pedestrian access.

Product/ Material

- 316 grade stainless steel

Supplier

As approved by the Authority

Construction Notes

- Handrail To comply with AS 1428
- Assembled from readily available sample components.
- Provide fixing details for Sydney Olympic Park Authority's approval prior to commencement of works.
- Structural engineer's review and certification will be required during all stages of design and installation.

Also refer to this manual:

- Section 3.1 PL16 for tactile ground surface indicators

Handrail - Freestanding



Sample - Handrail - free standing

Sydney Olympic Park Design Manual

SHELTER STRUCTURES

3.3

Shelter structures support the use and enjoyment of streets, public spaces and parks, providing shade and weather protection, and contributing to the unique identity of Sydney Olympic Parklands.

Shelter structures within Sydney Olympic apply a series of bespoke conceived and designed structures.

These reflect the particular requirements of Sydney Olympic Park in catering for large groups and gatherings and in developing a unique design and architectural identity for the precinct.

Toilet facilities are not included in the guidelines and will be subject to site specific designs reflecting the design and materials approach of shelters generally.

Guidelines include:

- picnic shelter
- parklands shade structure
- tensioned membrane shade structure
- bus shelter

3.3 Shelter Structures

3.3.1 Design Approach

Shelter structures across Sydney Olympic Park should be in harmony with the local character of the place. Shelter structures may be used across both the urban centre and the parklands. The shelter should be designed and positioned to be sympathetic with the landscape and to enhance the experience of the user.

Elements should be robust, vandal resistant and sustainable.

Elements should generally be easily demountable, removable, relocatable and recyclable.

3.3.2 Role within Parklands

Shelter elements should assist visitor enjoyment and appreciation of the environment. They should provide: a heightened experience for visitors;

- a heightened experience for visitors;
- appreciation of the landscape and its natural systems and processes;
- access to the park environs for all;
- shelter from the elements;
- comfort through provision of seating, and picnic tables, and
- legibility and understanding of the park through their layout, the use of signage and interpretive information.

3.3.3 Siting within the Parklands

Structures and furniture in most instances should be located near movement corridors throughout the Parklands. The selection and placement of structures and furniture should be such that the elements do not become spectacles in themselves but instead become integral to the landscape experience.

3.3.4 Relevant Standards

Shelter fabrication and installation is to have regard for the latest edition of all relevant Australian Standards and the Building Code of Australia (BCA).

Where Australian Standards do not exist, appropriate International Standards will apply.

3.3.5 Procurement

Procurement of elements must comply with the NSW Government's procurement policies.



3.3 Shelter Structure

REFER ALSO SHEETS S01-3

3.3.7 Parklands Shelter Structure Guidelines

Application

- Picnic shelter may be provided at various locations throughout the Parklands
- Refer S01-2 for picnic shelter siting guidelines
- Do not install picnic table set on ground that is steeper than 1:40.

Product/ Material

- Whyalla Series
 - Size options (size to be determined by the requirement of the project):
 - 4m x 4m (K631)
 - 5m x 5m (K632)
 - 6m x 6m (K633)
 - 8m x 6m (K634)
- Powder coated galvanised steel posts with steel roof frame
 - Colour : Woodland Grey (satin)
- Colorbond XRW roofing
 - Colour: Evening Haze
- Fixing:
 - Surfacing fixing to concrete pavement: Galvanised steel brackets and fixings
 - Sub-surface fixing to pavement: In-ground or bolt-down posts as approved by the Authority
- Other options to shelter as approved by the Authority.

Supplier

Landmarkpro

Address: 6/26 Flinders Parade North Lakes QLD 4509

Phone: 1300 768 230

Web: <https://www.landmarkpro.com.au/>

Construction Notes

- Install furniture as per manufacturers' recommendations.

Picnic Shelter



Sample - Picnic shelter

- Ensure the shelter is installed plumb and level, maintaining the specified clear height above the finished surface. Where the adjoining surface is sloped, custom leg lengths may be required to achieve the minimum clear height while ensuring a plumb and level installation.

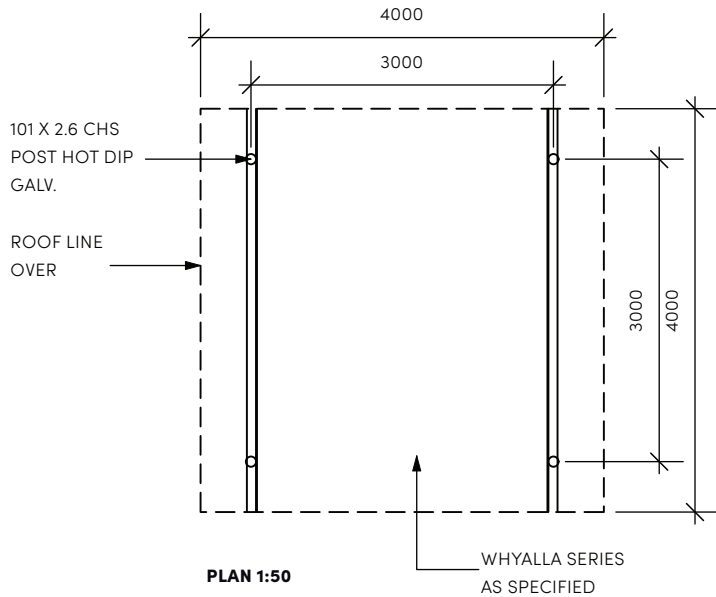

NOTE:
 PICNIC SHELTER SLAB FALLS NEED TO BE TAKEN INTO ACCOUNT IN SHELTER POST LENGTH TO ENSURE THAT 2100MM MIN. HEIGHT IS ACHIEVED TO ALL POSTS. THIS MEANS POST AT HIGH POINT IS WITH STANDARD HEIGHT, THE REST OF POSTS MUST BE FABRICATED LONGER AS REQUIRED. SHELTER SLAB MUST NOT BE STEEPER THAN 1:40

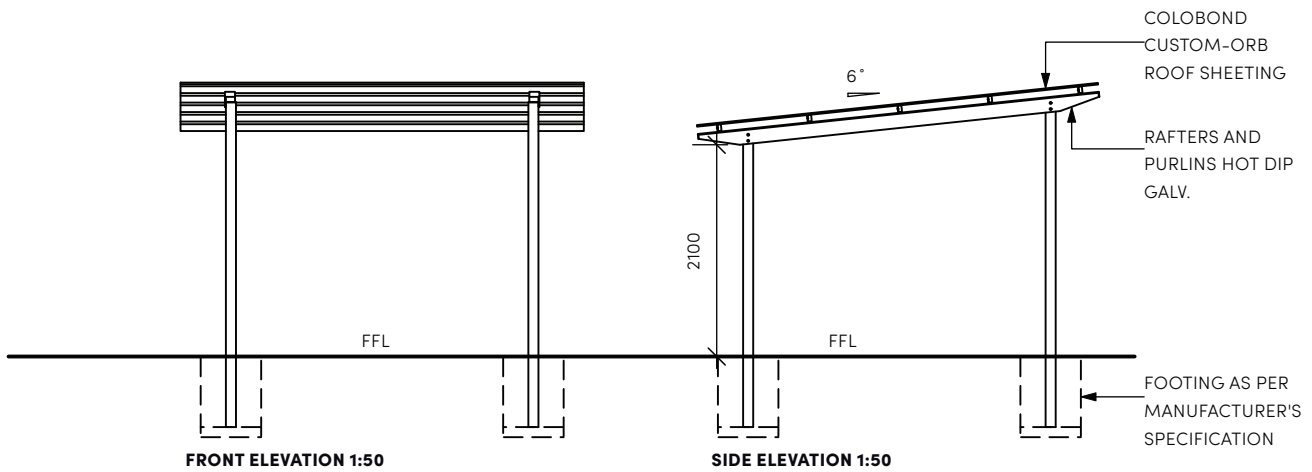

REFER ALSO SHEETS S01-1/2



SHELTER AT EDGE OF CLEARING

PICNIC SHELTER SITING

SHELTERS SHOULD BE SITED ALONG THE EDGES OF CLEARINGS DESIGNATED AS PICNIC ZONES. SHELTERS SHOULD BE FACING GENERALLY TO THE NORTH WHERE POSSIBLE

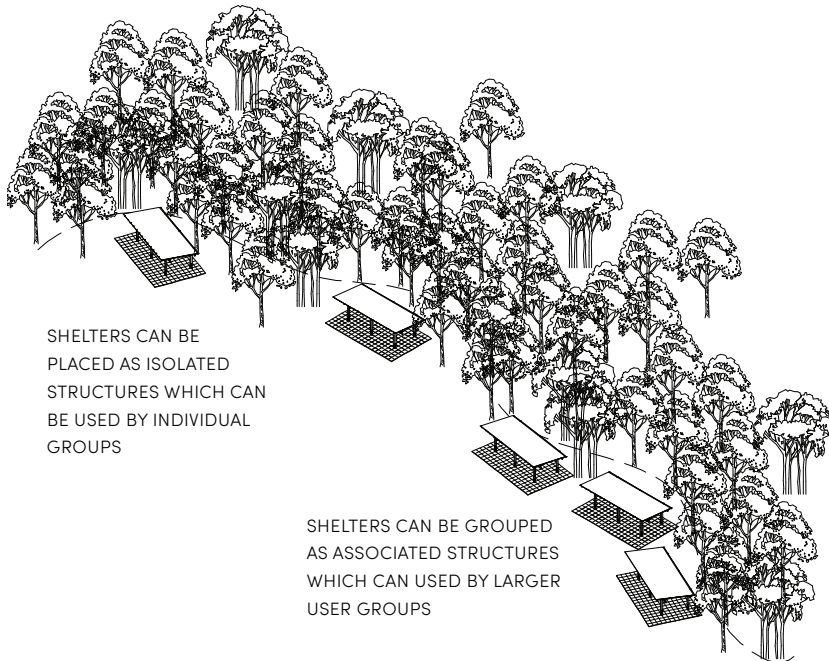

SHELTERS CAN BE PLACED AS ISOLATED STRUCTURES WHICH CAN BE USED BY INDIVIDUAL GROUPS

SHELTERS CAN BE GROUPED AS ASSOCIATED STRUCTURES WHICH CAN USED BY LARGER USER GROUPS

SHELTERS CAN BE PLACED AS ISOLATED STRUCTURES WHICH CAN BE USED FOR INDIVIDUAL GROUPS OR AS ASSOCIATED STRUCTURES WHICH CAN USED FOR LARGER USER GROUPS

EXAMPLES OF SITING

REFER ALSO SHEETS S01-/5/6/7/8

3.3 Shelter Structure

3.3.7 Shelter Structure Guidelines

Application

- Parklands - as advised by Sydney Olympic Park Authority.

Product/ Material

- Centra CO50
 - Fabric Colour: Mehler FR580-114 Yellow in general and white to Bicentennial Park
 - Steel colour: Pearl White
 - Subsurface fixing as per manufacturers' recommendations
- Porta P21
 - Fabric Colour: Mehler FR580-114 Yellow in general. Alternative colour option to be confirmed with Sydney Olympic Park Authority
 - Steel colour: Pearl White

Supplier

MakMax Australia

Address: Unit 1/115 Frederick St Northgate QLD 4013

Phone: 07 3633 5900

Web: <https://www.makmax.com.au/>

Construction Notes

- Install product as per manufacturers' recommendations.

Tension Membrane Shade Structure



Sample - Tension membrane shade structure

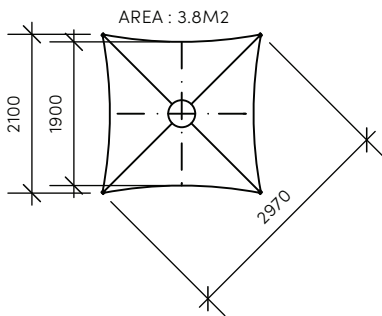

PLAN - SQUARE PORTA (P21) 1:100

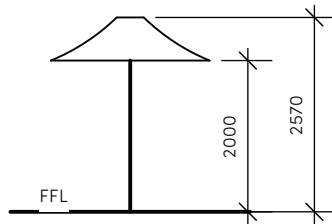

ELEVATION - SQUARE PORTA (P21) 1:100

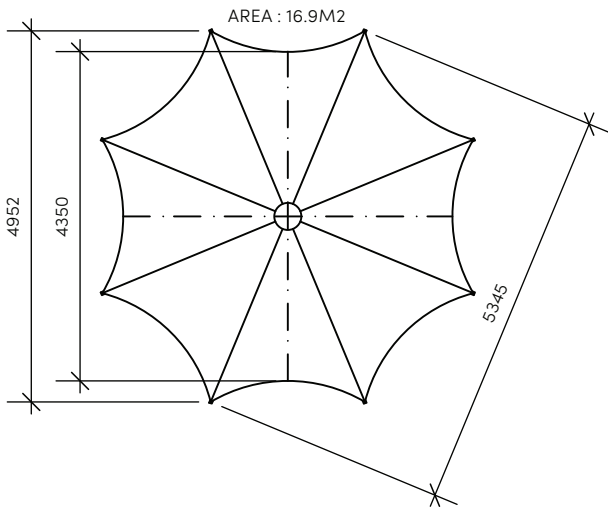

PLAN - OCTAGONAL CENTRA (CO50) 1:100

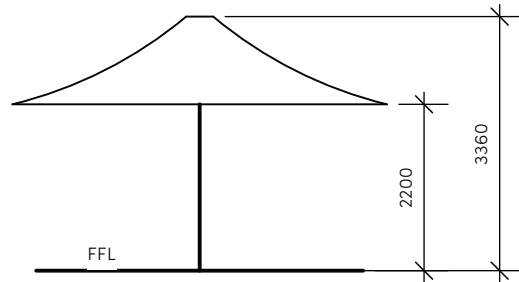

ELEVATION - OCTAGONAL CENTRA (CO50) 1:100

3.3 Shelter Structure

3.3.7 Shelter Structure Guidelines

Application

- Urban Area and Parklands
- Where there is a bus stop and adequate space is available, a bus shelter should be provided to offer weather protection for commuters.

Product/ Material

- Customised Evo Shelter
 - Size: 2362.8W x 3990L x 2548H (2243mm clear height)
 - Product specification to be confirmed with Sydney Olympic Park Authority

Supplier

Stoddart

Address: 39 Forest Way Karawatha Queensland 4117

Phone: 1300 307 289

Web: <https://stoddart.com.au/>

Construction Notes

- Install bus shelter as per manufacturers' recommendations.
- Bus Stops are required to have warning and directional TGSIs installed in accordance with The Disability Standards for Accessible Public Transport and AS1428.4.1.
- Bus stops arrangement to comply with AS1428.4.1.
- Ensure adequate space is provided between the kerb and seat as well as a hardstand that is level and firm with a gradient no steeper than 1:40.
- Ensure the shelter is installed plumb and level, maintaining the specified clear height above the finished surface. Where the adjoining surface is sloped, custom leg lengths may be required to achieve the minimum clear height while ensuring a plumb and level installation.

Bus Shelter



Sample - Bus shelter

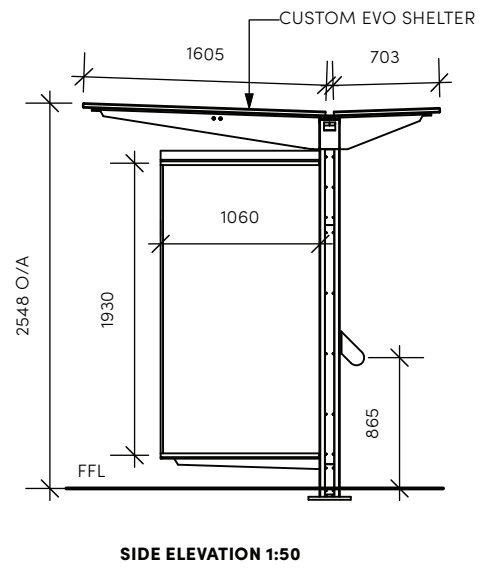
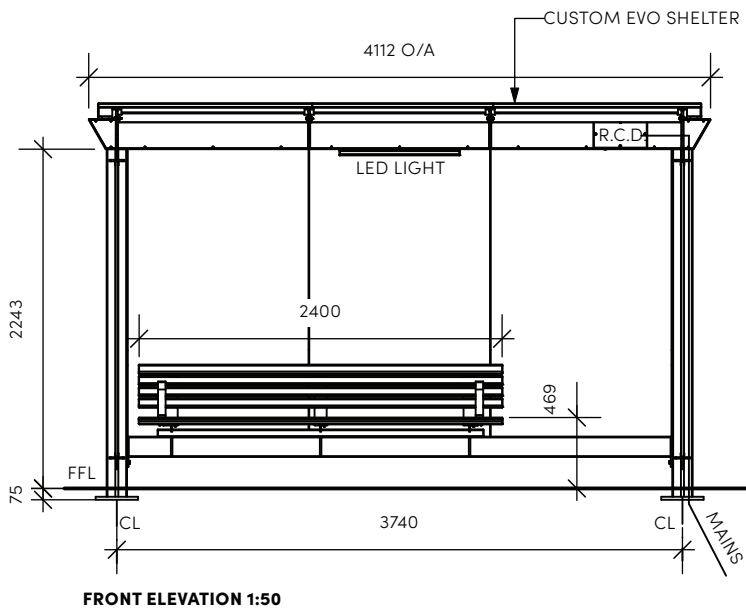
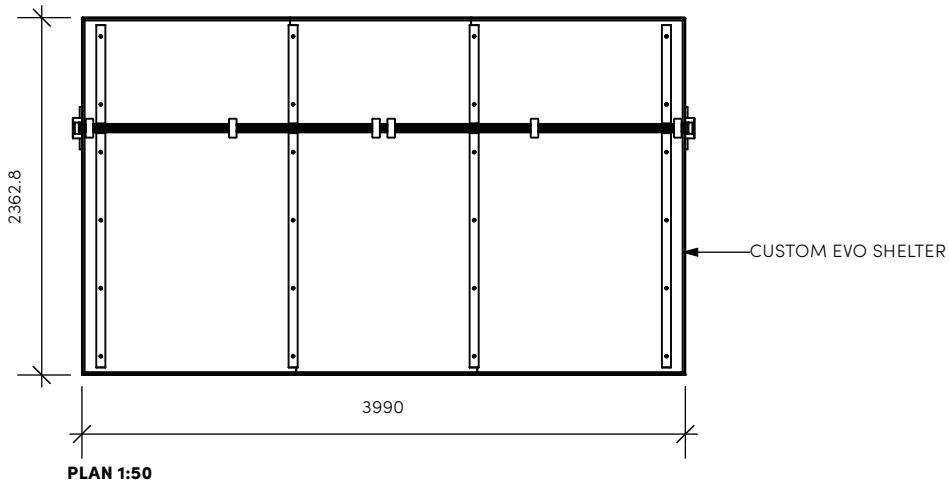
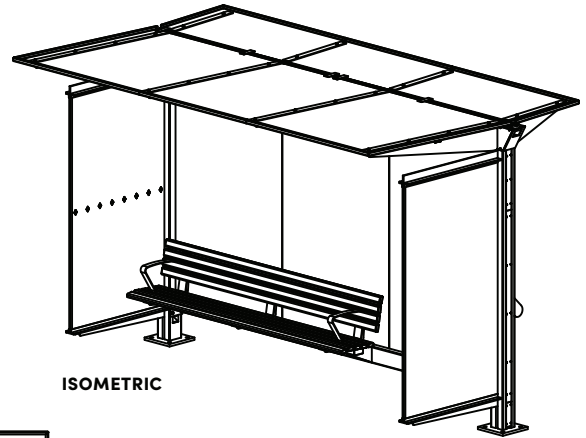

Sydney Olympic Park Design Manual

LIGHTING

3.4

Lighting to streets, public spaces and parks provide for the safe use and movement through these spaces at night.

Lighting must also positively contribute to the night time experience and look of spaces within Sydney Olympic Park

The provisions for pedestrian and cycle lighting within the public domain will be subject to the requirements for the specific type of space.

To streets lighting will be firstly guided by the applicable Australian Standards defining required lighting levels for vehicular and pedestrian safety.

Pedestrian lighting levels are again guided by applicable Australian Standard vary based on the type of area, with higher lux levels generally recommended for areas with more pedestrian traffic or potential safety concerns. For example, crosswalks and intersections will require higher levels, as will high public activity areas (e.g., civic squares, shopping malls).

Lighting to park areas is subject to site specific considerations related to:

- the need for key night-time movement routes (eg commuter access) to be lit
- the supporting of night time street activity and night economy
- the avoidance of light spill impact on habitat values

For general public domain lighting objectives principles and luminaire strategies refer to the separate Sydney Olympic Park Authority Public Domain Lighting Strategy.

Guidelines include:

- 12m high multi-function pole
- 9m high multi-function pole
- 6m high pedestrian light pole
- 3.5m or 4m high pedestrian light pole
- standard light poles typ 1 to type 3
- parklands solar light option 1 & 2

3.4 Lighting

3.4.4 Lighting Guidelines

Existing Custom Light Poles

All existing light poles that are part of the 2000 Olympic Games legacy are to be retained unless the precinct is being redeveloped. New poles are as described in the Design Manual (refer drawing L01 to L04). New precinct designs will be undertaken in collaboration with The Authority. The existing bespoke poles used for the 2000 Olympic Games will no longer be replicated for new works.



Sample - Custom Sydney Olympic park pole - type 2



Sample - Custom Sydney Olympic park pole - type 1



Sample - Custom Sydney Olympic park pole - type 3



Sample - Custom Sydney Olympic park pole - type 4



Sample - Custom Sydney Olympic park pole - type 5



Sample - Tapered light pole - Type 1



Sample - Tapered light pole - Type 2

3.4 Lighting

3.4.4 Lighting Guidelines

Application

- As per Sydney Olympic Park Lighting Strategy
- Urban Area
- For carriageway wider than 7m

Product/ Material

- 12m high 300 Series Maxi
 - Double, single or triple outreach arm as per engineers' specification
 - Other attachment options as per engineer's specification and to be approved by Sydney Olympic Park Authority
- Refer to Sydney Olympic Park Lighting Strategy and IECM for structural and luminaires specification and requirements.

Supplier

Multipole

Address: 2/81 Bassett Street Mona Vale NSW 2103

Phone: +61 2 9997 1211

Web: <https://multipole.com.au/>

Construction Notes

- The height of the poles and distance of the poles must be determined by the project landscape architects and Electrical and Lighting Engineers based on the approved urban design and use of the area.
- Refer to the separate Sydney Olympic Park Lighting Strategy and IECM for detailed requirements.
- Install light pole as per manufacturers' recommendations.
- Ensure the lighting pole is installed plumb and level.
- Structural engineer's design and certification of light footing will be required during all stages of design and installation.

12m High Multi-Function Pole



Sample - 12m High Multi-function Pole

3.4.4 Lighting Guidelines

Application

- As per Sydney Olympic Park Lighting Strategy
- Urban Area
- For carriageway 7m wide or less

Product/ Material

- 9m high 300 Series Mini
 - Single outreach arm as per engineers' specification
 - Other attachment options as per engineer's specification and to be approved by Sydney Olympic Park Authority
- Refer to Sydney Olympic Park Lighting Strategy and IECM for structural and luminaires specification and requirements.

Supplier

Multipole

Address: 2/81 Bassett Street Mona Vale NSW 2103

Phone: +61 2 9997 1211

Web: <https://multipole.com.au/>

Construction Notes

- The height of the poles and distance of the poles must be determined by the project landscape architects and Electrical and Lighting Engineers based on the approved urban design and use of the area.
- Refer to the separate Sydney Olympic Park Lighting Strategy and IECM for detailed requirements.
- Install light pole as per manufacturers' recommendations.
- Ensure the lighting pole is installed plumb and level.
- Structural engineer's design and certification of light footing will be required during all stages of design and installation.

9m High Multi-Function Pole



Sample - 9m High Multi-function Pole

3.4 Lighting

3.4.4 Lighting Guidelines

Application

- As per Sydney Olympic Park Lighting Strategy
- Urban Area
- Parklands
- For large public domain areas e.g. pedestrian space
- For footpath wider than 3.7m in Urban Area and footpath 3m or wider in parklands

Product/ Material

- 6m high Circular Section Pipe Pole
 - Pole OD to be approved by Sydney Olympic Park Authority
 - Other attachment options as per engineer's specification and to be approved by Sydney Olympic Park Authority
 - Colour as approved by the Authority
- Refer to Sydney Olympic Park Lighting Strategy and IECM for structural and luminaires specification and requirements.

Supplier

Vicpole

Address: 62 Jersey Rd Bayswater Vic 3153

Phone: +61 418 230 465

Web: <https://www.vicpole.com.au/>

Construction Notes

- The height of the poles and distance of the poles must be determined by the project landscape architects and Electrical and Lighting Engineers based on the approved urban design and use of the area.
- Refer to the separate Sydney Olympic Park Lighting Strategy and IECM for detailed requirements.
- Install light pole as per manufacturers' recommendations.
- Ensure the lighting pole is installed plumb and level.

6m High Pedestrian Light Pole



Sample - 6m High Pedestrian Light Pole

- Structural engineer's design and certification of light footing will be required during all stages of design and installation.

3.4.4 Lighting Guidelines

Application

- As per Sydney Olympic Park Lighting Strategy
- Urban Area
- Parklands
- For large public domain areas e.g. pedestrian space
- For footpath 3.7m wide or less in Urban Area and footpath less than 3m in parklands

Product/ Material

- 3.5m or 4m high Circular Section Pipe Pole
 - Pole OD to be approved by Sydney Olympic Park Authority
 - Other attachment options as per engineer's specification and to be approved by Sydney Olympic Park Authority
 - Colour as approved by the Authority
- Refer to Sydney Olympic Park Lighting Strategy and IECM for structural and luminaires specification and requirements.

Supplier

Vicpole

Address: 62 Jersey Rd Bayswater Vic 3153

Phone: +61 418 230 465

Web: <https://www.vicpole.com.au/>

Construction Notes

- The height of the poles and distance of the poles must be determined by the project landscape architects and Electrical and Lighting Engineers based on the approved urban design and use of the area.
- Refer to the separate Sydney Olympic Park Lighting Strategy and IECM for detailed requirements.
- Install light pole as per manufacturers' recommendations.
- Ensure the lighting pole is installed plumb and level.

3.5 or 4m High Pedestrian Light Pole



Sample - 3.5m or 4m High Pedestrian Light Pole

- Structural engineer's design and certification of light footing will be required during all stages of design and installation.

3.4 Lighting

3.4.4 Lighting Guidelines

Application

As per Sydney Olympic Park Lighting Strategy

Product/ Material

- 12m high street light
 - Galvanised tapered main shaft
 - Galvanised single round tapered steel outreach arm
- Refer to Sydney Olympic Park Lighting Strategy and IECM for luminaires specification and requirements.

Supplier

To be Advised by the Authority

Construction Notes

- Refer to the separate Sydney Olympic Park Lighting Strategy and IECM for detailed requirements.
- Install light pole as per manufacturers' recommendations.
- Ensure the lighting pole is installed plumb and level.
- Structural engineer's design and certification of light footing will be required during all stages of design and installation.

Standard Pole - Type 1



Sample - Standard pole - type 1

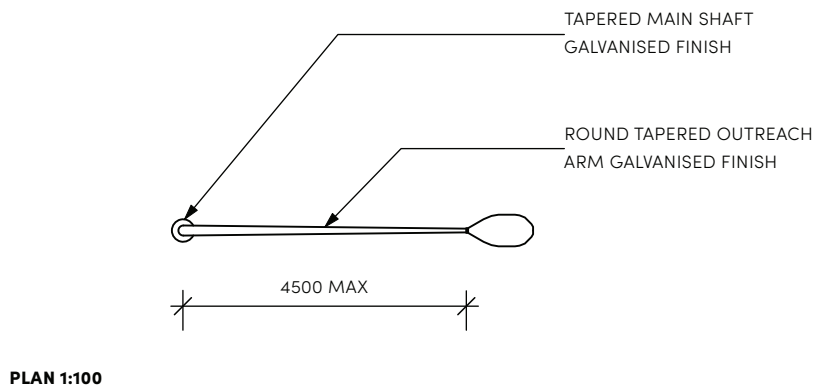
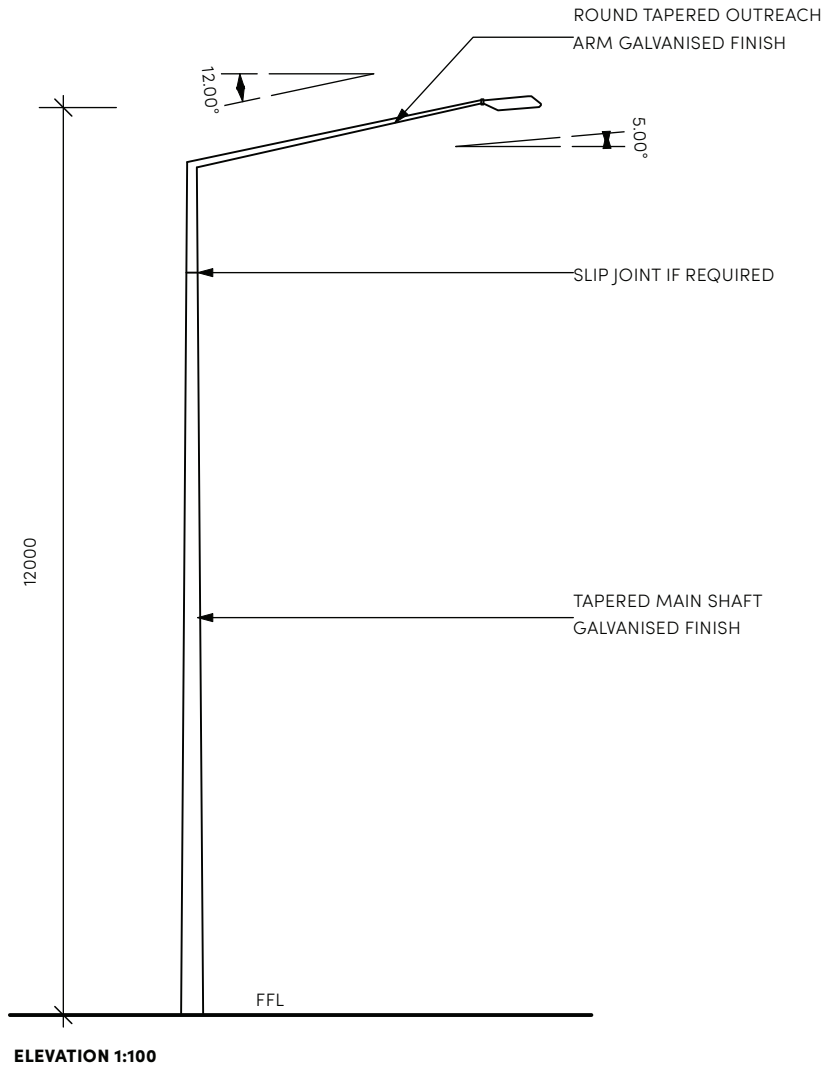

3.4 Lighting

3.4.4 Lighting Guidelines

Application

As per Sydney Olympic Park Lighting Strategy

Product/ Material

- 9m high street light
 - Galvanised tapered main shaft
 - Galvanised single round tapered steel outreach arm
- Refer to Sydney Olympic Park Lighting Strategy and IECM for luminaires specification and requirements.

Supplier

To be Advised by the Authority

Construction Notes

- Refer to the separate Sydney Olympic Park Lighting Strategy and IECM for detailed requirements.
- Install light pole as per manufacturers' recommendations.
- Ensure the lighting pole is installed plumb and level.
- Structural engineer's design and certification of light footing will be required during all stages of design and installation.

Standard Pole - Type 2



Sample - Standard pole - type 2

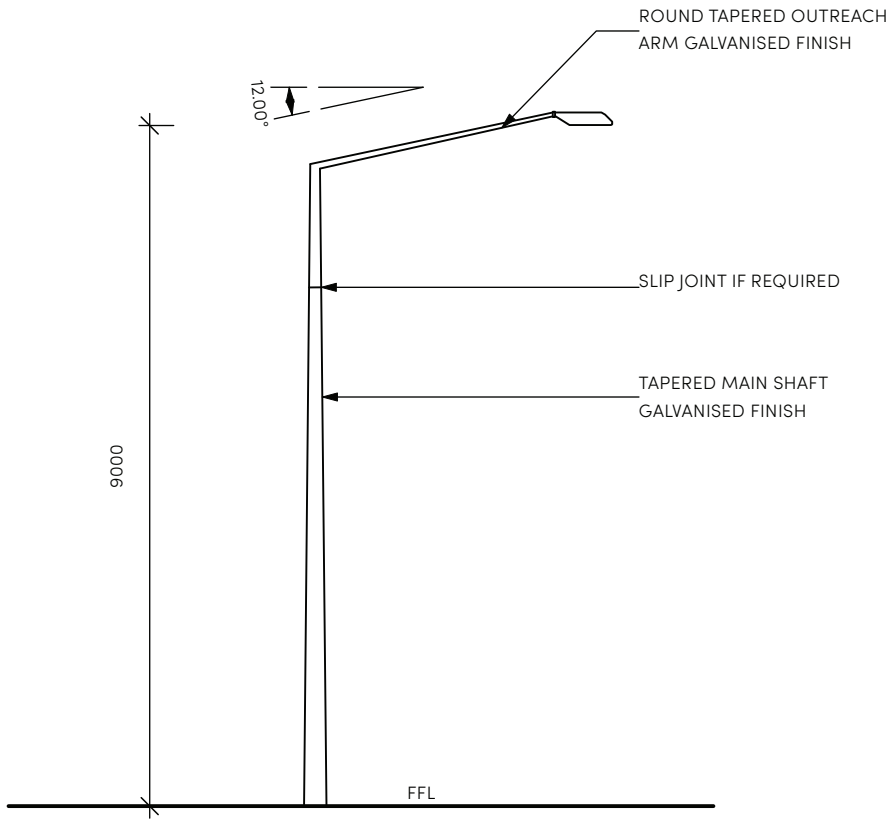

ELEVATION 1:100

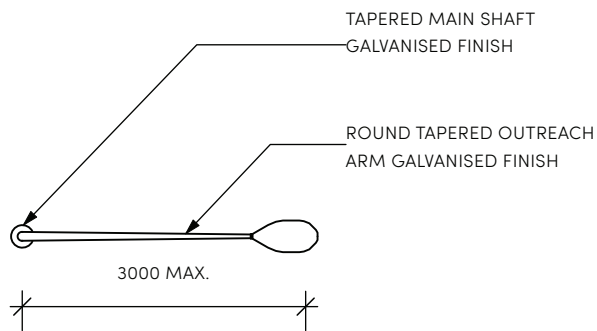

PLAN 1:100

3.4 Lighting

3.4.4 Lighting Guidelines

Standard Pole - Type 3

Application

As per Sydney Olympic Park Lighting Strategy

Product/ Material

- 12m high street light
 - Galvanised tapered main shaft
 - Galvanised double round tapered steel outreach arms
- Refer to Sydney Olympic Park Lighting Strategy and IECM for luminaires specification and requirements.

Supplier

To be Advised by the Authority

Construction Notes

- Refer to the separate Sydney Olympic Park Lighting Strategy and IECM for detailed requirements.
- Install light pole as per manufacturers' recommendations.
- Ensure the lighting pole is installed plumb and level.
- Structural engineer's design and certification of light footing will be required during all stages of design and installation.

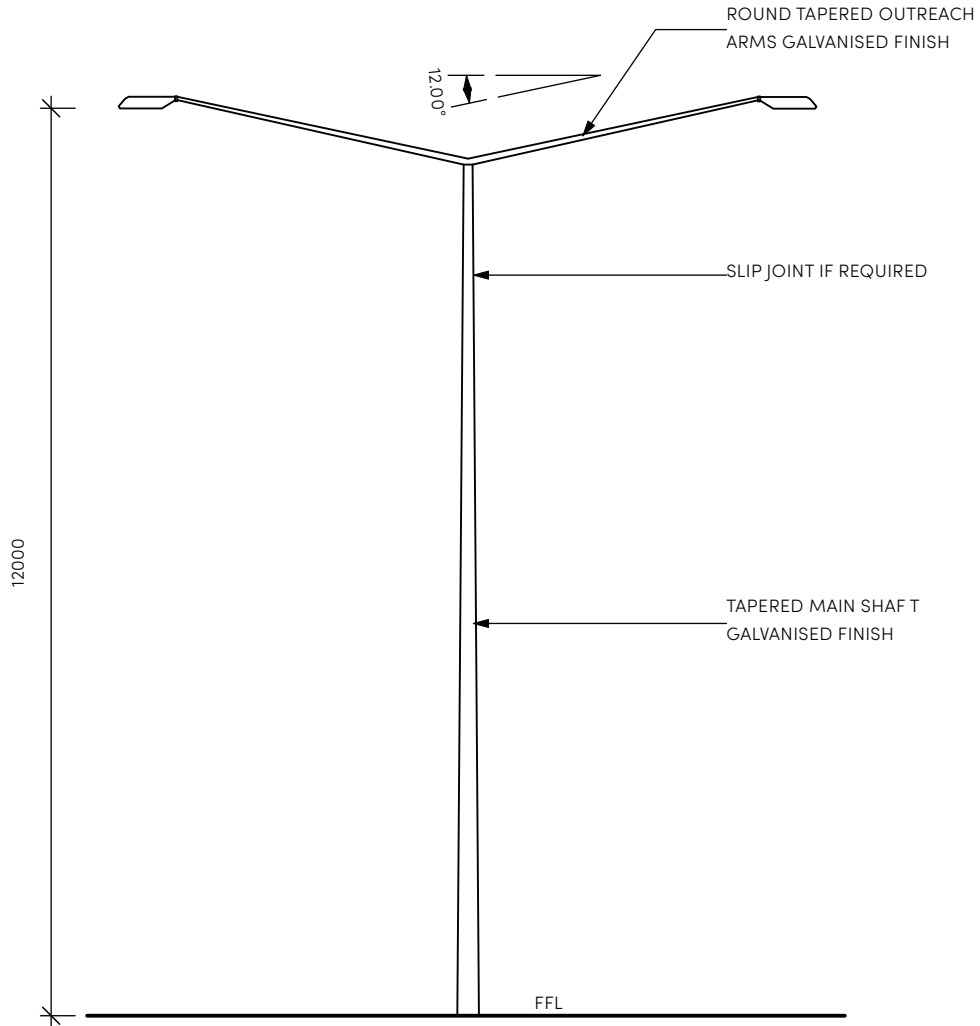

ELEVATION 1:100

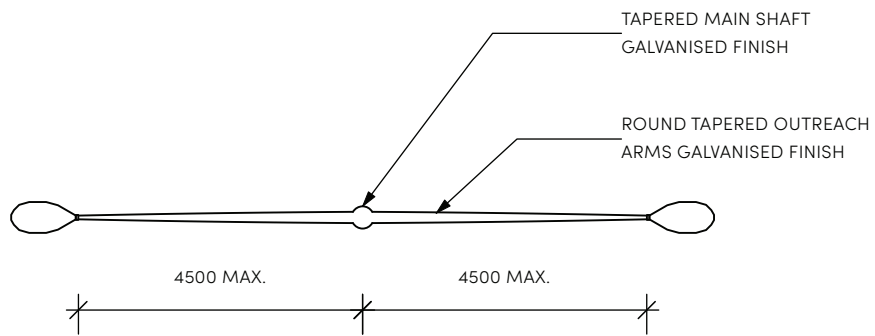

PLAN 1:100

3.4 Lighting

3.4.4 Lighting Guidelines

Application

As per Sydney Olympic Park Lighting Strategy

Product/ Material

- 5.5m high light pole with solar panel
 - Pole specification to be confirmed with Sydney Olympic Park Authority
 - Battery requirements to be confirmed with Sydney Olympic Park Authority
- Refer to Sydney Olympic Park Lighting Strategy and IECM for luminaires specification and requirements.

Supplier

To be Advised by the Authority

Construction Notes

- Refer to the separate Sydney Olympic Park Lighting Strategy and IECM for detailed requirements.
- Install light pole as per manufacturers' recommendations.
- Ensure the lighting pole is installed plumb and level.
- Structural engineer's design and certification of light footing will be required during all stages of design and installation.

Parklands Solar Light - Option 1



Sample - Parklands Solar Lighting - Option 1

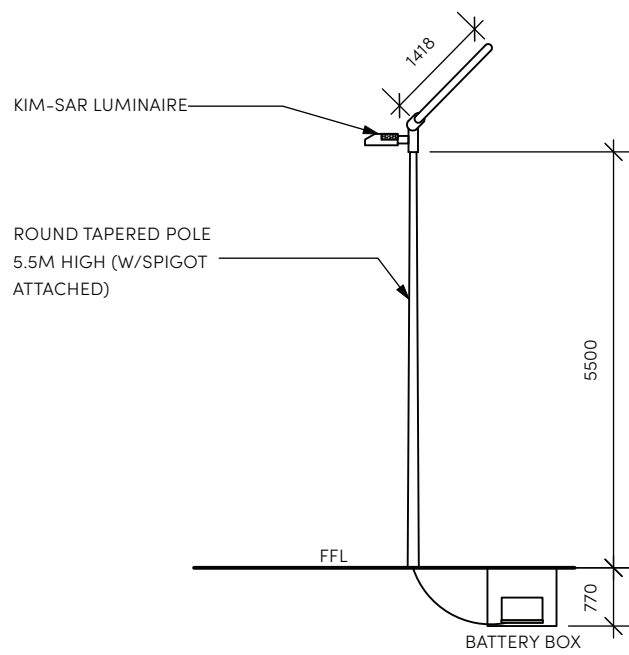

ELEVATION 1:100

3.4 Lighting

3.4.4 Lighting Guidelines

Application

As per Sydney Olympic Park Lighting Strategy

Product/ Material

- 5.5m high light pole with solar panel
 - Pole specification to be confirmed with Sydney Olympic Park Authority
 - Battery requirements to be confirmed with Sydney Olympic Park Authority
- Refer to Sydney Olympic Park Lighting Strategy and IECM for luminaires specification and requirements.

Supplier

To be Advised by the Authority

Construction Notes

- Refer to the separate Sydney Olympic Park Lighting Strategy and IECM for detailed requirements.
- Install light pole as per manufacturers' recommendations.
- Ensure the lighting pole is installed plumb and level.
- Structural engineer's design and certification of light footing will be required during all stages of design and installation.

Parklands Solar Light - Option 2



Sample - Parklands Solar Lighting - Option 2

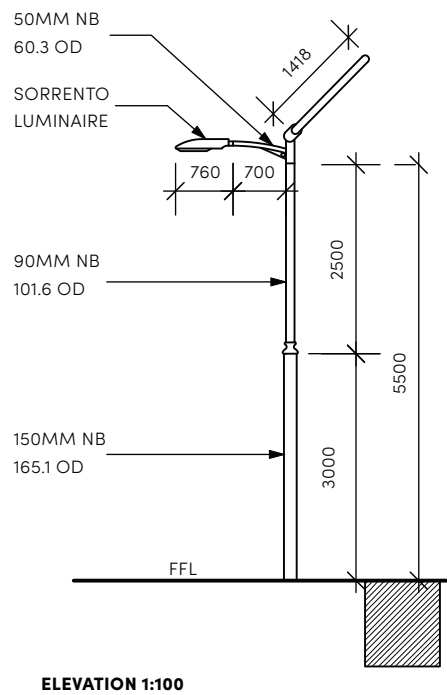

Sydney Olympic Park Design Manual

ENGINEERING ELEMENTS

3.5

These engineered elements play a fundamental role in the public domain and support the necessary drainage and utility functions.

Engineering Elements have a primary utilitarian function but as integrated elements within streets, public spaces and parks, must also be designed and implemented to complement the intent and quality of all other public domain elements.

Guidelines include:

- Precast raised kerb
- Precast flush kerb
- Insitu flush kerb
- Insitu kerb and gutter – standard
- Insitu kerb and gutter – wide
- Permeable kerb
- Insitu swale / dish drain

3.5 Engineering Elements

3.5.1 Objectives

A range of kerbs and related engineered elements are used in different streets and pedestrian areas at Sydney Olympic Park to:

- express the street hierarchy;
- visually define the footpath areas;
- signify different levels of pedestrian and vehicular priorities;
- direct water into the storm water system, and
- implement water sensitive urban design measures.

3.5.2 Relevant Standards

The engineering elements guidelines are to be applied in conjunction with the latest edition of all relevant Australian Standards. Where Australian Standard do not exist, appropriate International Standards will apply.

Relevant Australian Standards include but are not limited to the following:

- AS 2758 Aggregates and rock for engineering purposes
- AS 1379 Specification and supply of concrete
- AS 2876 Concrete kerbs and channels (gutters) – Manually or machine placed
- AS 1428 Design for access and mobility

3.5.3 Procurement

Procurement of elements must comply with the NSW Government's procurement policies.



3.5 Engineering Elements

3.5.4 Engineering Elements Guidelines

Application

- Urban Area
 - Olympic Boulevard

Product/ Material

- Precast concrete raised kerb 300W x 1200L
- Concrete Strength: 32MPa
- Large aggregate: Marrangaroo gravel or similar
- Fine aggregate: Washed river sand
- Off-white cement
- Acid etch finish

Supplier

As approved by the Authority

Construction Notes

- To engineers' final specification.
- Placement and installation of kerbs to manufacturers' specification.
- Recycled base materials to engineers' final specification.
- Finish of concrete flush with surrounding footpath surface level.

Also refer to Sydney Olympic Park

Authority's IECM:

- K016

Typical Precast Raised Kerb



Sample - Precast raised kerb

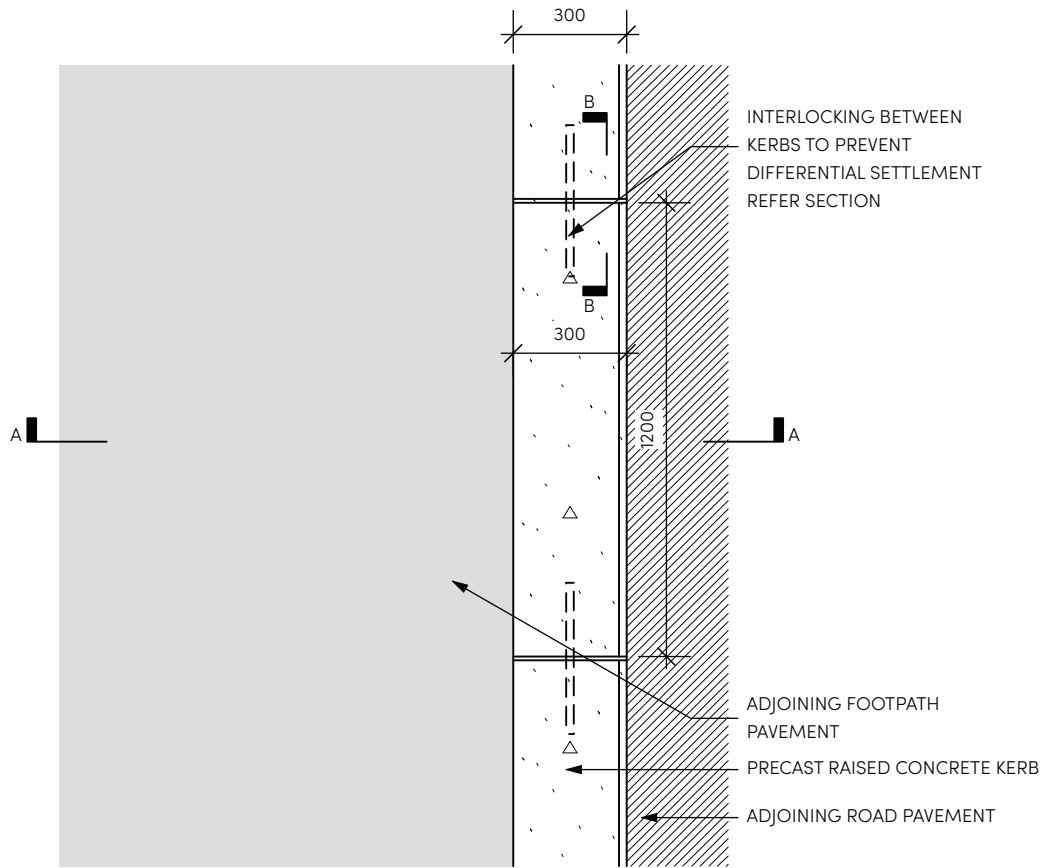

TYPICAL PRECAST KERB PLAN 1:20

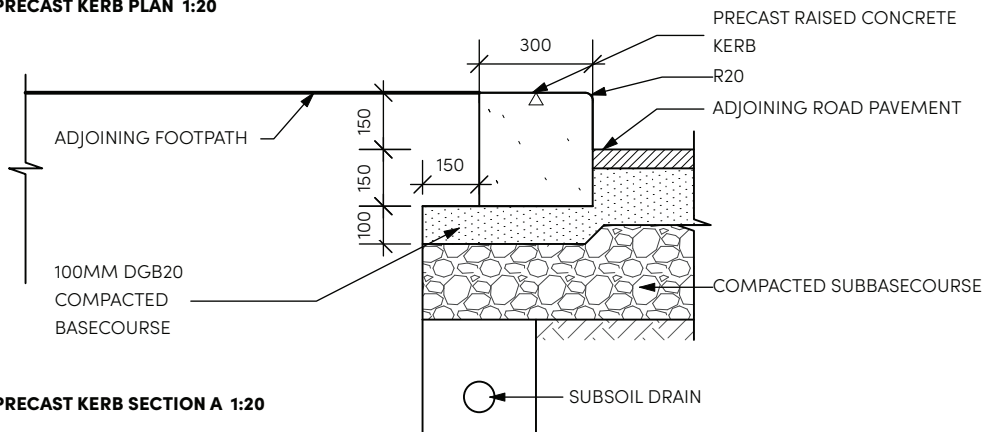

TYPICAL PRECAST KERB SECTION A 1:20

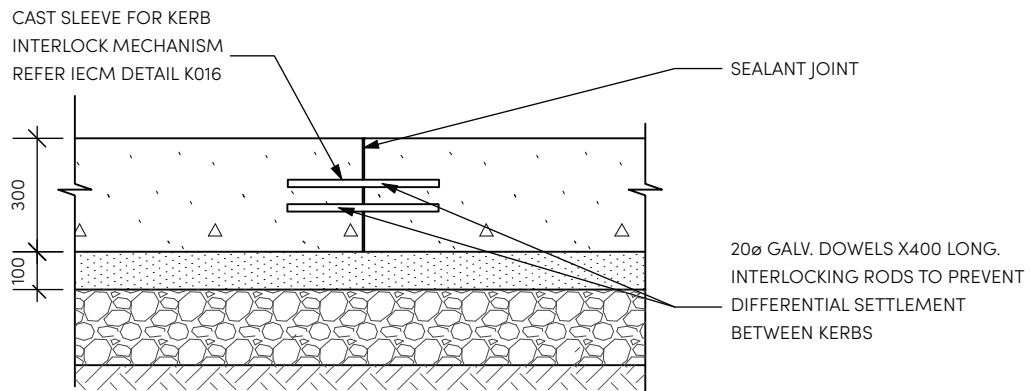

TYPICAL PRECAST KERB SECTION B 1:20

3.5 Engineering Elements

3.5.4 Engineering Elements Guidelines

Application

- Urban Area
 - Olympic Boulevard

Product/ Material

- Precast concrete flush kerb 300W x 1200L
- Concrete Strength: 32MPa
- Large aggregate: Marrangaroo gravel or similar
- Fine aggregate: Washed river sand
- Off-white cement
- Acid etch finish

Supplier

As approved by the Authority

Construction Notes

- To engineers' final specification.
- Placement and installation of kerbs to manufacturers' specification.
- Recycled base materials to engineers' final specification.
- Finish of concrete flush with surrounding surface level.
- Flush kerb to comply with AS1428 requirements.

Also refer to this manual:

- Section 3.1 PL16 for tactile ground surface indicators

Also refer to Sydney Olympic Park

Authority's IECM:

- K016

Typical Precast Flush Kerb



Sample - Precast flush kerb

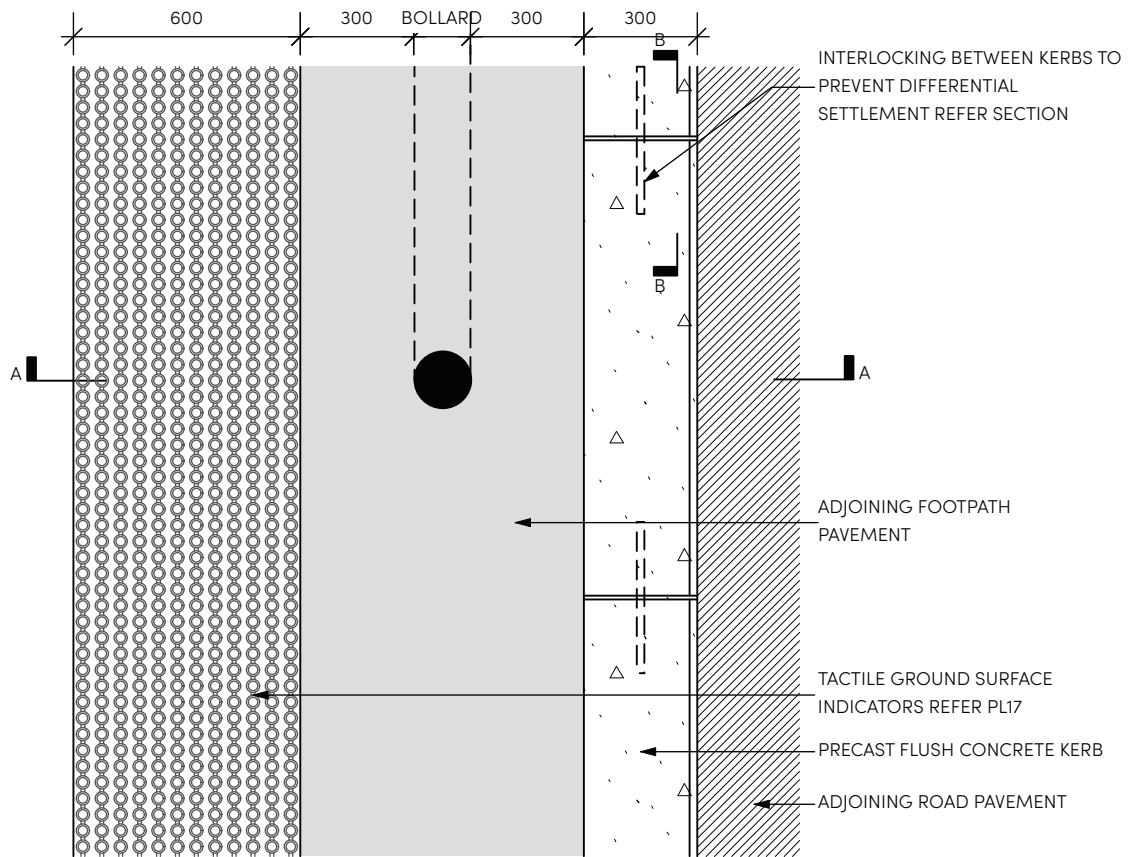

TYPICAL PRECAST FLUSH KERB PLAN 1:20

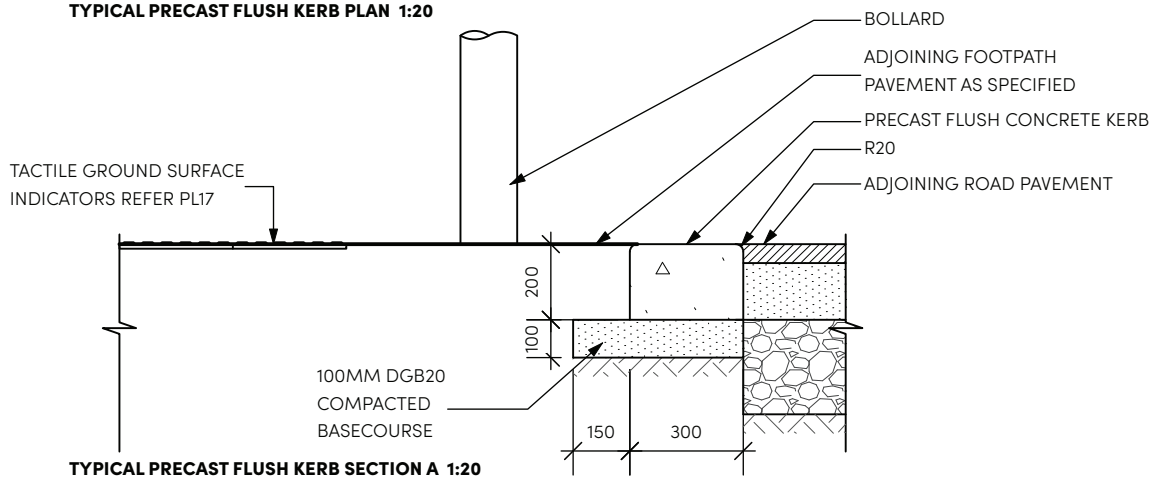

TYPICAL PRECAST FLUSH KERB SECTION A 1:20

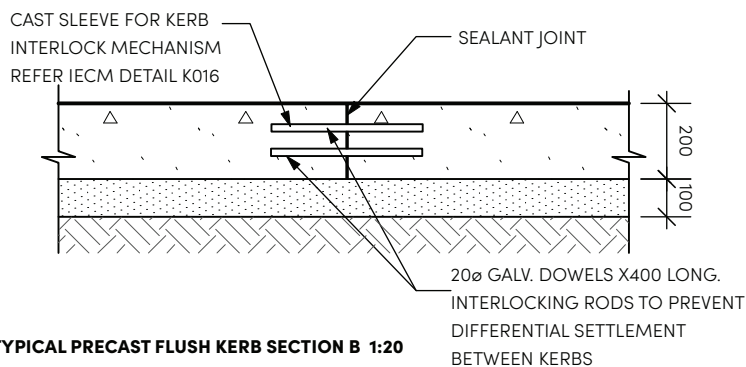

TYPICAL PRECAST FLUSH KERB SECTION B 1:20

3.5 Engineering Elements

3.5.4 Engineering Elements Guidelines

Application

- Urban Area
 - Showground Road
 - Grand Parade
 - Marray Rose Avenue
- Parklands

Product/ Material

- Insitu concrete flush kerb 300 or 680 or 800W x 1200L
- Concrete Strength: 32MPa
- Standard concrete mix to match approved sample
- Standard concrete finish

Supplier

As approved by the Authority

Construction Notes

- To engineers' final specification.
- Tool joints at 1200mm centres.
- Recycled base materials to engineers' final specification.
- Finish of concrete flush with surrounding surface level.
- Flush kerb to comply with AS1428 requirements.

Also refer to this manual:

- Section 3.1 PL16 for tactile ground surface indicators

Also refer to Sydney Olympic Park

Authority's IECM:

- K003

Typical Insitu Flush Kerb



Sample - Insitu flush kerb

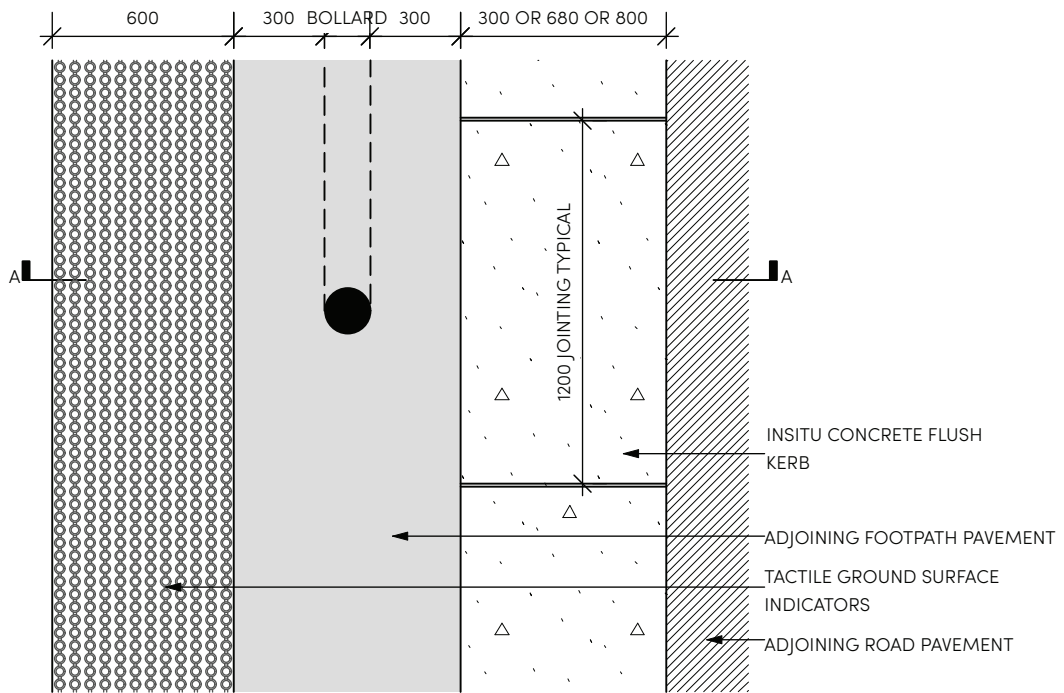

TYPICAL INSITU FLUSH KERB PLAN 1:25

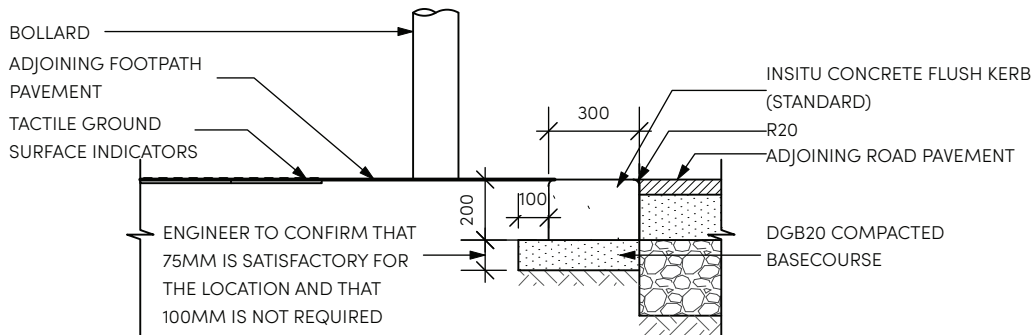

TYPICAL INSITU FLUSH KERB SECTION A 1:25

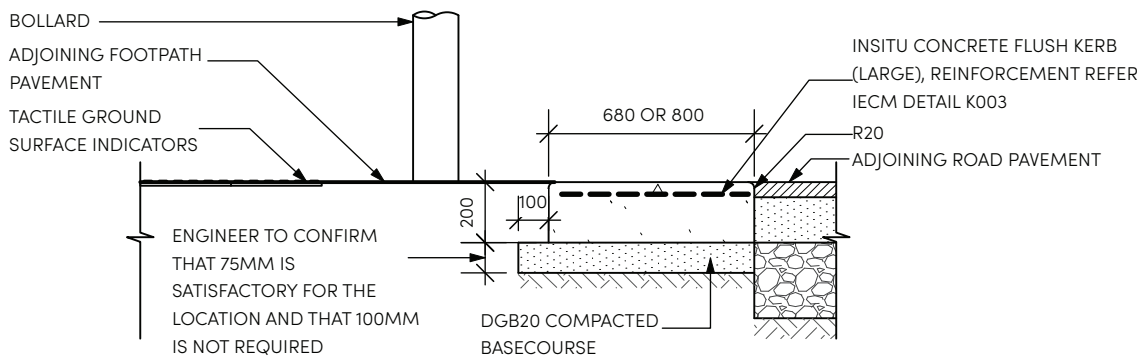

TYPICAL INSITU FLUSH KERB SECTION A 1:25

3.5 Engineering Elements

3.5.4 Engineering Elements Guidelines

Application

- Urban Area
- Parklands

Product/ Material

- Insitu concrete kerb and gutter to match RMS standard kerb type
- Concrete Strength: 32MPa
- Standard concrete mix to match approved sample
- Standard concrete finish

Supplier

As approved by the Authority

Construction Notes

- To engineers' final specification.
- Tool joints at 1200mm centres.
- Mastic joints at 3600mm centres.
- Recycled base materials to engineers' final specification.
- Finish of concrete flush with surrounding footpath surface level.

Also refer to Sydney Olympic Park

Authority's IECM:

- K001

Typical Insitu Kerb & Gutter - Standard Size



Sample - Insitu kerb & gutter - standard size

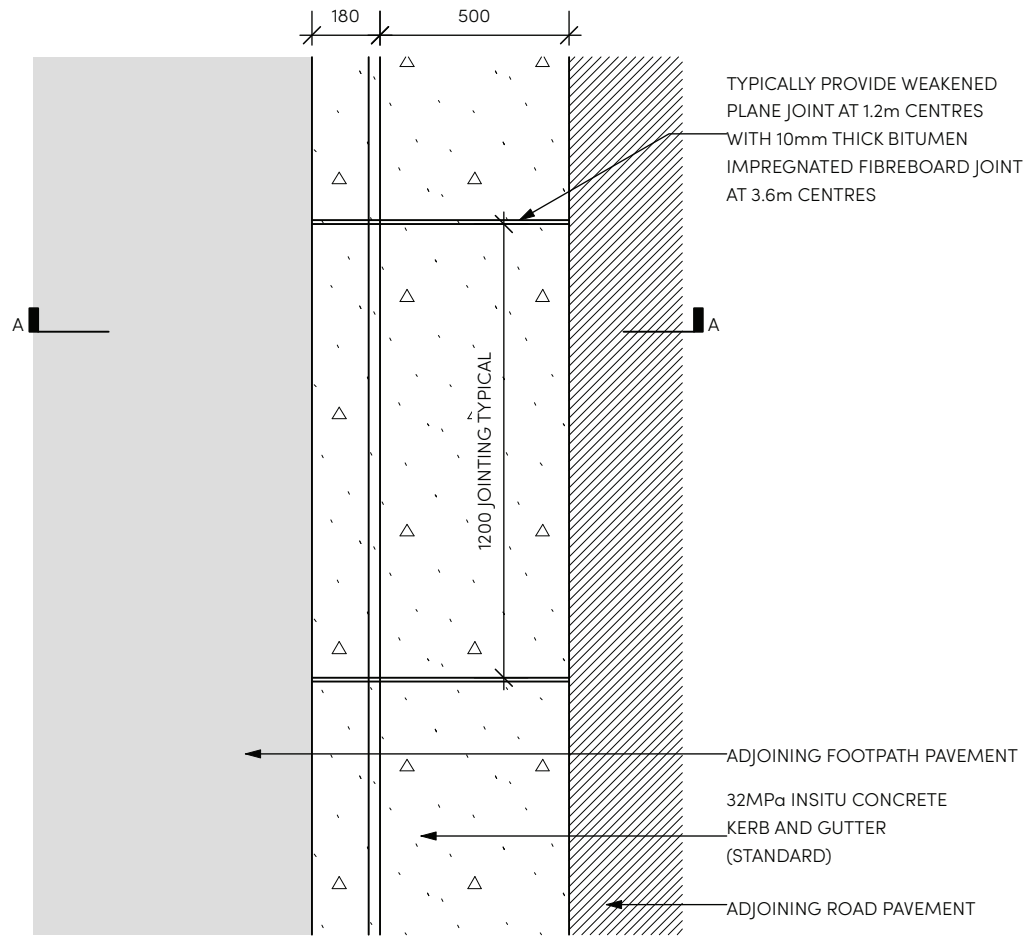

TYPICAL INSITU CONCRETE KERB AND GUTTER (STANDARD) PLAN 1:20

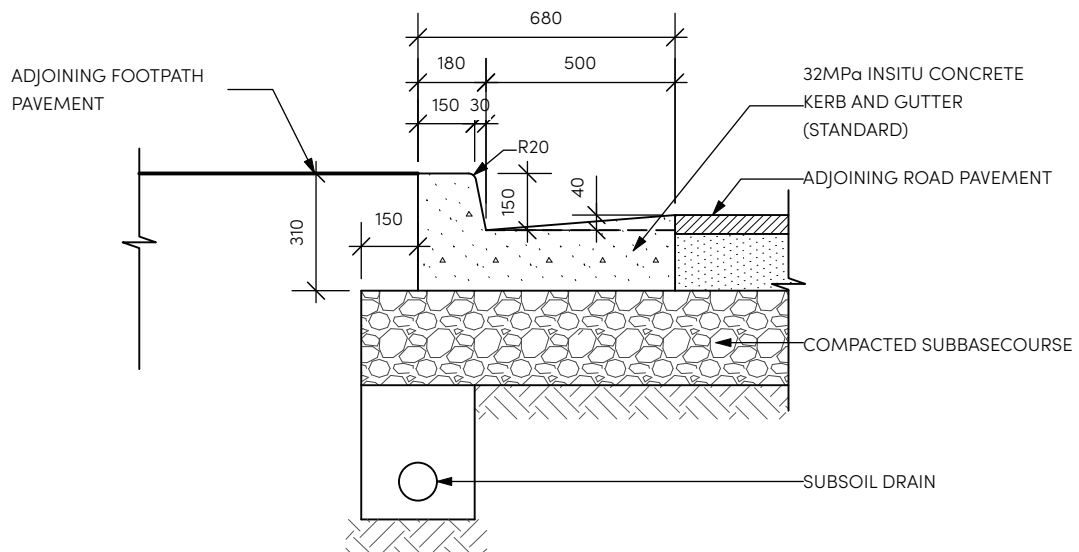

TYPICAL INSITU CONCRETE KERB AND GUTTER (STANDARD) SECTION A 1:20

3.5 Engineering Elements

3.5.4 Engineering Elements Guidelines

Application

- Urban Area
 - Dawn Fraser Avenue
 - Murray Rose Avenue
 - Herb Elliott Avenue
 - Shane Gould Avenue

Product/ Material

- Insitu concrete kerb and gutter, 1200mm length nominal
- Concrete Strength: 32MPa
- Standard concrete mix to match approved sample
- Standard concrete finish

Supplier

As approved by the Authority

Construction Notes

- To engineers' final specification.
- Tool joints at 1200mm centres.
- Mastic joints at 3600mm centres.
- Recycled base materials to engineers' final specification.
- Finish of concrete flush with surrounding footpath surface level.

Also refer to Sydney Olympic Park

Authority's IECM:

- K001

Typical Insitu Kerb & Gutter - Large Size



Sample - Insitu kerb & gutter - large size

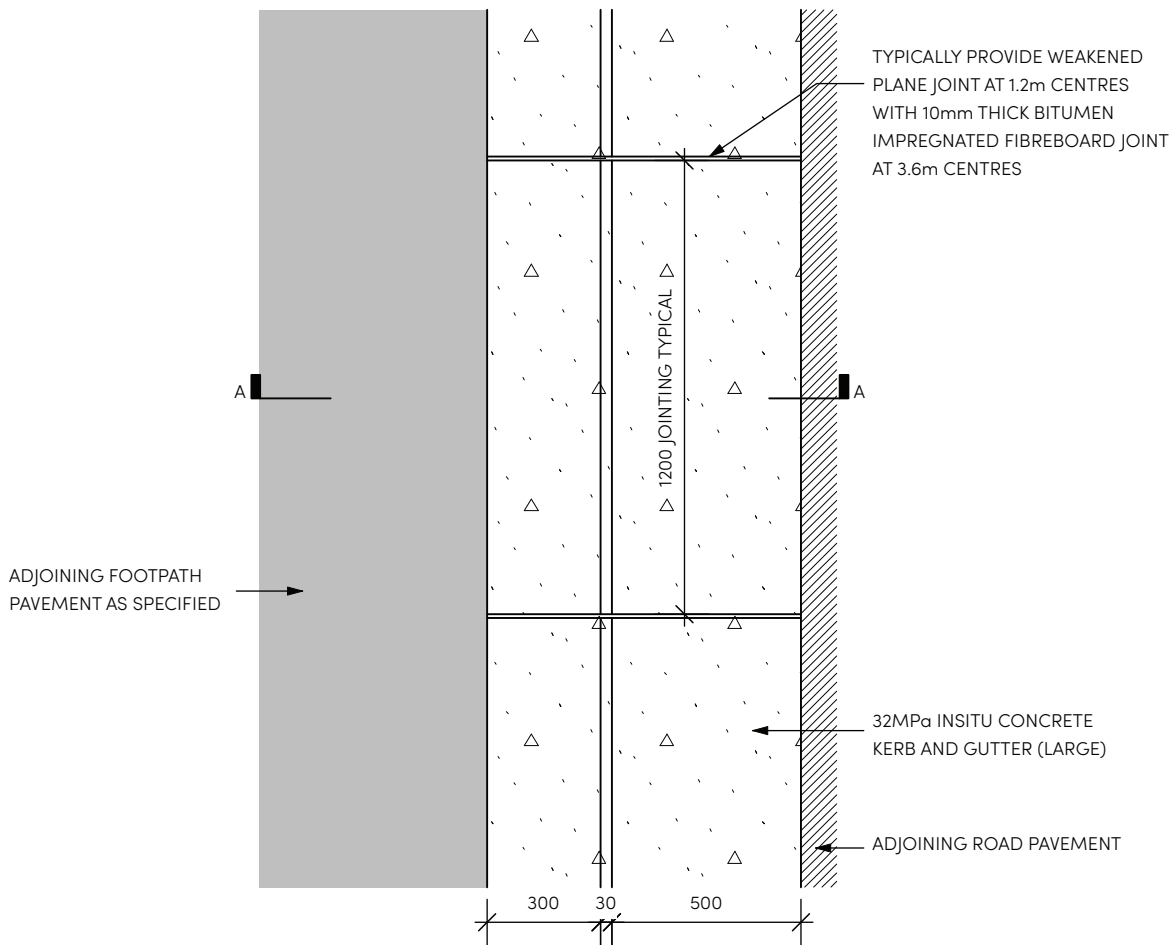

TYPICAL INSITU CONCRETE KERB AND GUTTER (LARGE) PLAN 1:20

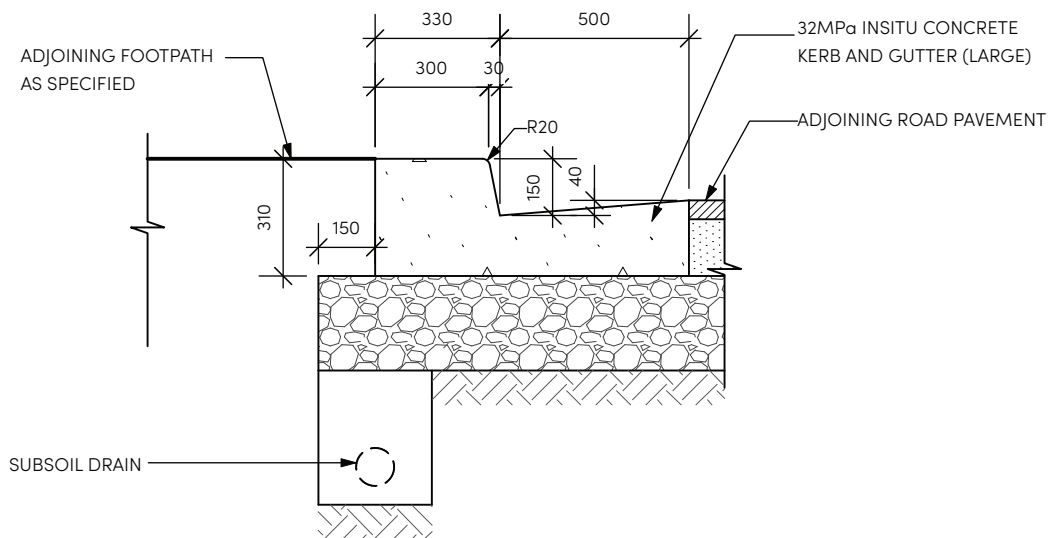

TYPICAL INSITU CONCRETE KERB AND GUTTER (LARGE) SECTION A 1:20

3.5 Engineering Elements

3.5.4 Engineering Elements Guidelines

Application

- Urban Area
 - Where passive irrigation or WSUD is applied

Product/ Material

- 32MPa Insitu concrete flush kerb with starter bars to accomodate permeable kerb
- 32MPa Insitu concrete permeable kerb
- Standard concrete mix to match approved sample
- Standard concrete finish

Supplier

As approved by the Authority

Construction Notes

- To engineers' final specification.
- Recycled base materials to engineers' final specification.
- Finish of concrete flush with surrounding footpath surface level.

Also refer to Sydney Olympic Park

Authority's IECM:

- K004

Typical Permeable Kerb



Sample - Permeable kerb

3.5 Engineering Elements

3.5.4 Engineering Elements Guidelines

Application

- Urban Area
- Parklands

Product/ Material

- 32MPa Insitu concrete V-drain swale to match RMS standard type
- Standard concrete mix to match approved sample
- Standard concrete finish

Supplier

As approved by the Authority

Construction Notes

- To engineers' final specification.
- Recycled base materials to engineers' final specification.
- Finish of concrete flush with surrounding surface level.
- V-drain swale to comply with AS1428 requirements.

Also refer to this manual:

- Section 3.1 PL16 for tactile ground surface indicators

Also refer to Sydney Olympic Park

Authority's IECM:

- K007

Typical V-drain Swale



Sample - V-drain swale

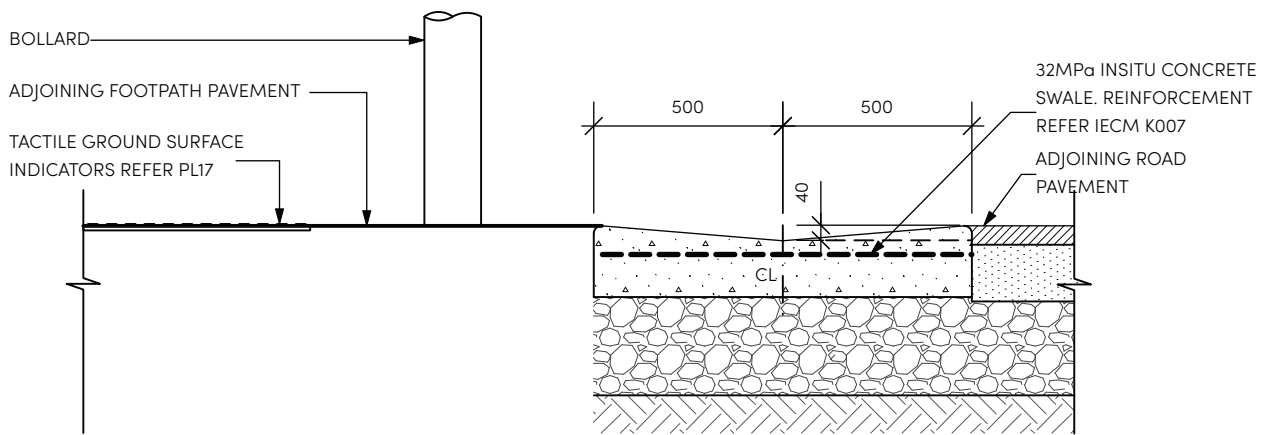
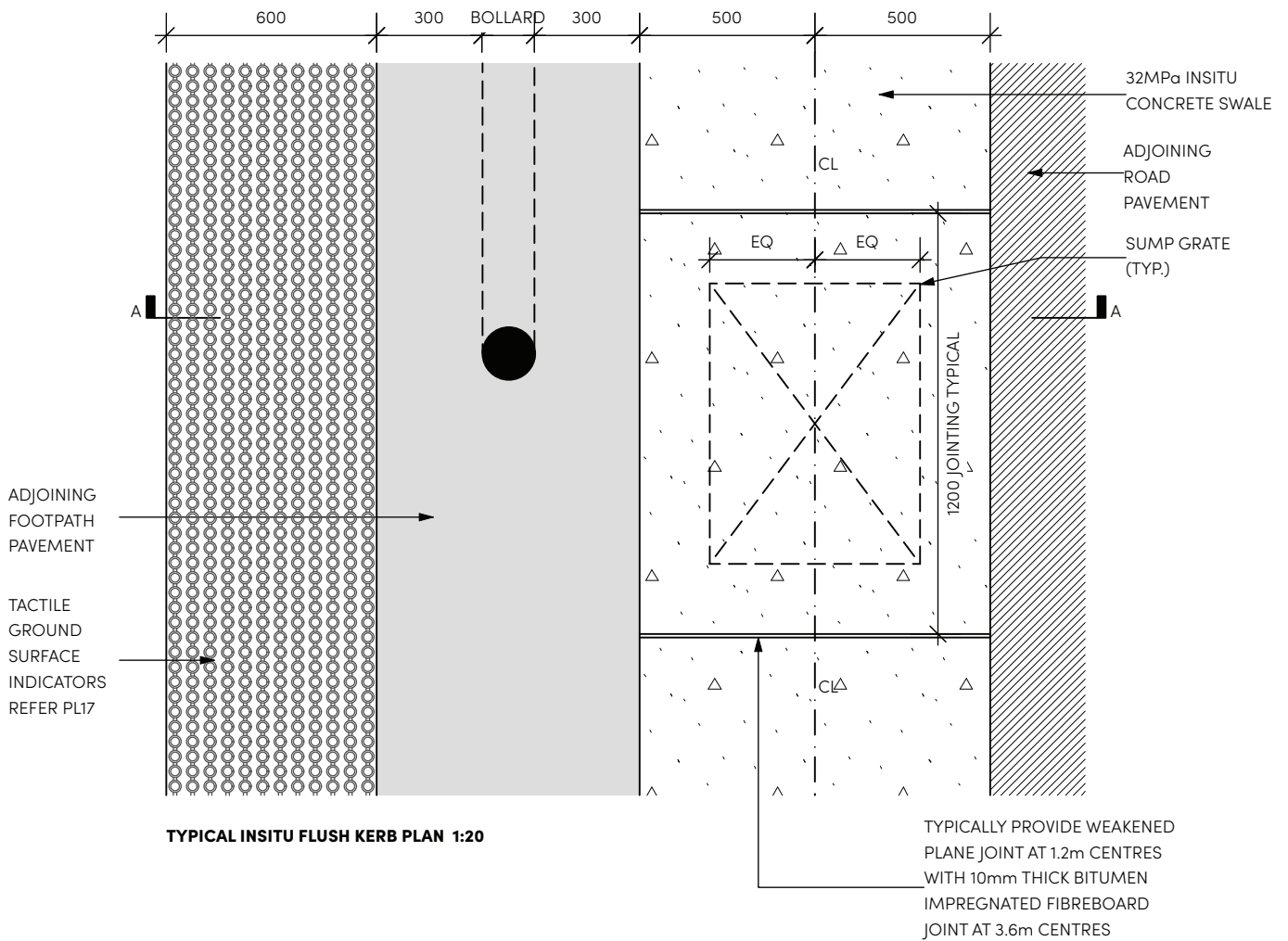

3.5 Engineering Elements

3.5.4 Engineering Elements Guidelines

Application

- Urban Area
- Parklands
- Where vehicular access is required from the public road to private properties or parklands.

Product/ Material

- 32MPa concrete vehicle layback
- Standard concrete mix to match approved sample
- Standard concrete finish

Supplier

As approved by the Authority

Construction Notes

- To engineers' final specification.
- Recycled base materials to engineers' final specification.
- Finish of concrete flush with surrounding footpath surface level.
- Driveways to comply with AS/NZS 2890.1:2004 Parking Facilities Part 1 - Off Street Parking.

Also refer to this manual:

- Section 3.1 PL06 for paved vehicle crossing

Also refer to Sydney Olympic Park

Authority's IECM:

- K013

Typical Vehicle Kerb Layback



Sample - Vehicle layback

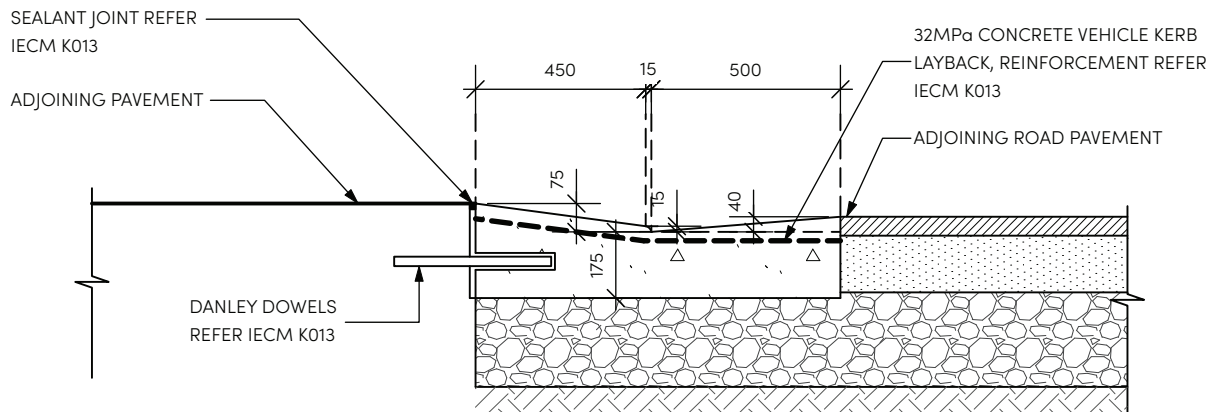
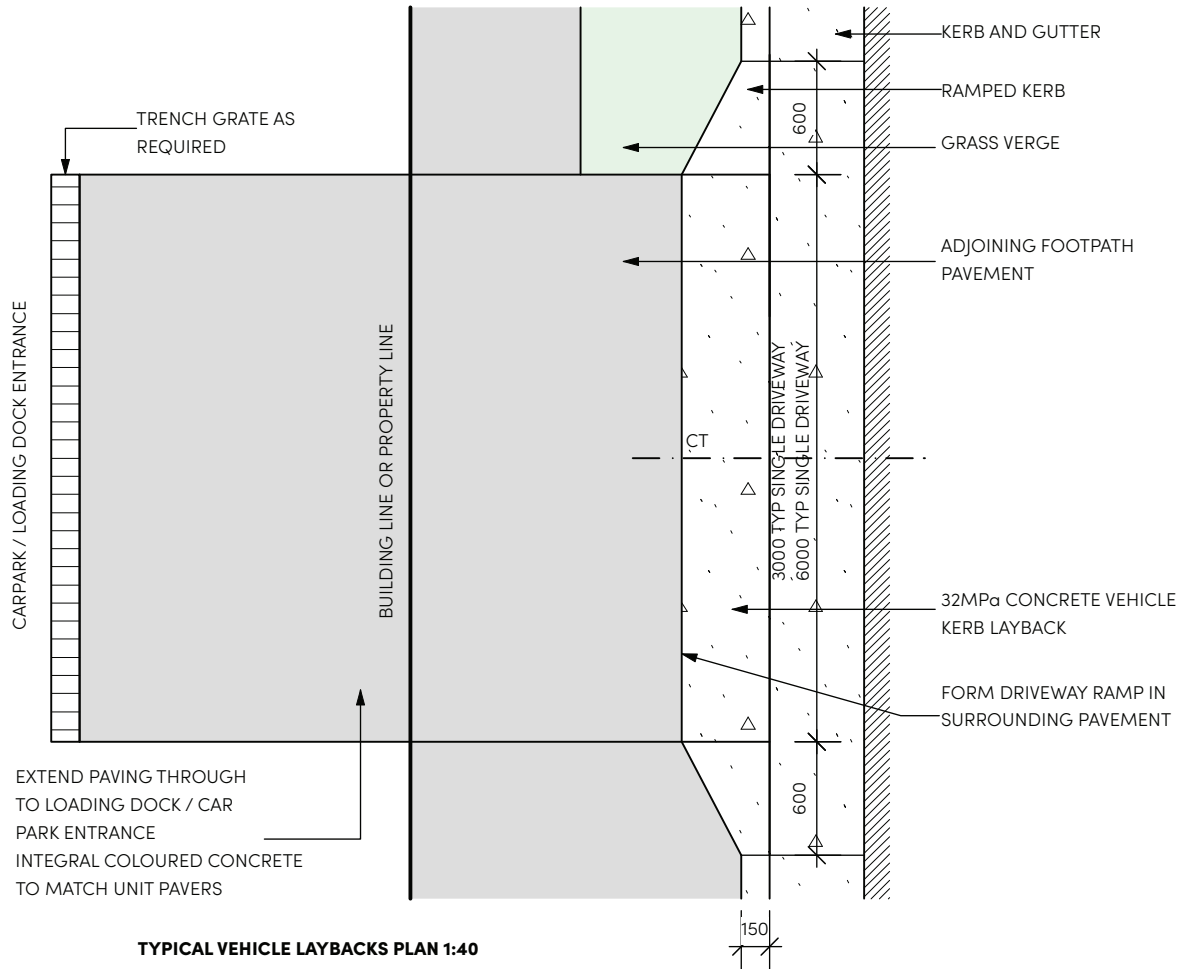

Sydney Olympic Park Design Manual

PLANTING

3.6

Trees are essential for beauty and amenity in the public domain. They provide shade, cooler temperatures and higher humidity during the hot summer months as well as wind mitigation, fauna habitat and ambience generally.

Sydney Olympic Park has a strong legacy of landscape and street tree plantings established for the 2000 Olympic Games which is to be protected and enhanced.

Street tree plantings address the following strategy outlined in 3.6.4 to 3.6.6.

The Parklands provide a natural setting to the town which is to be enhanced by creating landscape links to the park and reinforcing indigenous plantings.

Guidelines include:

- Tree planting in verge less than 1.5m
- Tree planting in verge greater than 1.5m
- Tree Planting with Tree Grate in paved footpath
- Tree Planting with garden bed in paved footpath
- Tree Planting with structural Soil Cells in paved footpath
- Tree Planting in Carriageway - Passive Irrigation
- Tree Planting in Carriageway - Bioretention Tree Pit
- Tree Planting in Park
- Garden Bed and Mass Planting Bed
- Revegetation
- Turf
- Swale

3.6 Planting

3.6.1 Objectives

Plantings at Sydney Olympic Park are to achieve the following objectives:

- Retain and strengthen the existing plantings and landscape character;
- Prioritise species that are sufficiently hardy to flourish in the difficult conditions, and
- Retain and enhance existing heritage plantings.

3.6.2 Relevant Standards

Relevant Australian Standards include but are not limited to the following:

- AS 3743 Potting mixes
- AS 4419 Soils for landscaping and garden use
- AS 4454 Composts, soil conditioners and mulches
- AS 4373 Pruning of amenity trees
- Other guidance documents include but are not limited to the following:
 - NATSPEC Guide: Specifying Trees – a guide to assessment of tree quality

3.6.3 Procurement

Procurement must comply with the NSW Government's procurement policies.

3.6.4 Planting Species Selection

Plant selection is a vital component of environmentally responsive development and long-term landscape sustainability. The following principles should be considered when undertaking plant selection:

- All plant species must be selected based on site-specific conditions, including local climate, soil type, drainage, sun and shade exposure, and other environmental factors.
- Preference should be given to locally indigenous species that are well-adapted to the natural conditions of the area and contribute to local ecosystem resilience.
- A diverse mix of species should be encouraged to promote ecological biodiversity and habitat value.
- Plant selection must support plant health, reduce long-term maintenance requirements, and enhance the ecological performance of the site.

- Where non-native (exotic) species are used, they must be non-invasive, suitable for the specific planting location, and capable of surviving with minimal water and maintenance inputs.
- Planting palettes should consider seasonal variation, visual interest, functional outcomes such as shade provision and pollutant filtering, and alignment with the local landscape character.

Refer Table 3.6.1 for street tree planting species list, long-term maintenance requirements, and enhance the ecological performance of the site.

Table 3.6.1 Street Tree Planting Species in Urban Center

Botanic Name	Spread (S) and Height (H) in Meter	Native (N) or Exotic (E)
<i>Acmena smithii</i>	6(S) x 12(H)	N
<i>Araucaria cunninghamiana</i>	8(S) x 30(H)	N
<i>Backhousia myrtifolia</i>	4(S) x 7(H)	N
<i>Brachychiton acerifolius</i>	8(S) x 20(H)	N
<i>Brachychiton discolor</i>	8(S) x 20(H)	N
<i>Brachychiton × roseus</i>	6(S) x 12(H)	N (Hybrid)
<i>Corymbia maculata</i>	12(S) x 30(H)	N
<i>Eucalyptus citriodora</i>	10(S) x 35(H)	N
<i>Eucalyptus ficifolia</i> 'Summer Beauty'	5(S) x 8(H)	N (Cultivar)
<i>Eucalyptus microcorys</i>	12(S) x 30(H)	N
<i>Eucalyptus pilularis</i>	12(S) x 30(H)	N
<i>Eucalyptus punctata</i>	10(S) x 20(H)	N
<i>Eucalyptus saligna</i>	12(S) x 30(H)	N
<i>Eucalyptus sideroxylon</i>	10(S) x 25(H)	N
<i>Ficus microcarpa</i> 'Hillii'	12(S) x 20(H)	N
<i>Ficus rubiginosa</i>	15(S) x 20(H)	N
<i>Flindersia australis</i>	8(S) x 15(H)	N
<i>Hymenosporum flavum</i>	5(S) x 12(H)	N
<i>Jacaranda mimosifolia</i>	10(S) x 15(H)	N
<i>Lophostemon confertus</i>	10(S) x 20(H)	N
<i>Melaleuca decora</i>	6(S) x 15(H)	N
<i>Melaleuca leucadendra</i>	10(S) x 20(H)	N
<i>Melaleuca quinquenervia</i>	10(S) x 25(H)	N
<i>Melaleuca styphelioides</i>	8(S) x 20(H)	N
<i>Pyrus calleryana</i>	7(S) x 12(H)	E
<i>Pyrus ussuriensis</i>	7(S) x 10(H)	E

3.6.5 Tree Placement and Spacing

- All new/replacement trees are to be minimum 200L pot size to Natspec Plant Supply Specifications.
- Where new planting is required on existing streets, tree and understorey species and spacing are to match existing.
- Street tree spacing is dependent upon the size of the tree at maturity. Refer table 3.6.2 for recommended spacing, subject to site conditions
- Street tree and understorey planting is to comply with intersection sightline and other relevant traffic requirements. Refer Table 3.6.3 for details
- Service locations are to be checked and required clearances are subject to Sydney Olympic Park Authority and relevant service authority requirements.
- No trees are to be planted along the length of a bus zone. If there is any existing trees within the bus zone, it will need to be trimmed if needed to maintain the clear zone required by the NSW State Transit Bus Infrastructure Guide.

Table 3.6.2 Street Tree Size and Spacing

Tree Size	Height	Crown Spread	Spacing
Small	4-9m	3-6m	6-8m cts.
Medium	7-10m	7-9m	8-10m cts.
Large	9-20m	10-16m	10-15m cts.

Table 3.6.3 Indicative Street Tree Clearance

Streetscape Element	Indicative Minimum Clearance
Street intersection - approach side	10m from intersection kerb line
Street intersection - non-approach side	7m from intersection kerb line
Traffic Signals	>10m from signal pole on approach side
Bus Stops	3m
Pedestrian Crossing - approach side	10m
Shared lanes	1m
Driveways - approach side	3m
Driveways - non-approach side	2m
Stormwater Inlet/Outlet	2m
Street Light Pole	3m
Cycleways	0.5m

3.6.6 Soil Volume

Adequate soil volume is essential for the healthy growth, development, and long-term survival of street trees. The following minimum soil volume requirements apply based on tree size:

Table 3.6.4 Soil Volume Requirements for Street Trees

Tree Size	Height	Crown Spread	Min. Soil Volume Required Per Tree
Small	4-9m	3-6m	13.8m ³
Medium	7-10m	7-9m	21.4m ³
Large	9-20m	10-16m	32.65m ³

These volumes ensure trees have sufficient space for root expansion, water infiltration, and nutrient uptake. Where multiple trees are planted within a shared or connected planting zone, total soil volume requirements may be reduced due to the collective benefit of a larger root zone.

To optimise soil conditions, particularly in compacted urban settings, structural soil or structural soil cell systems (e.g. Stratavault) should be used where appropriate. These systems help maximise usable soil volume beneath pavements while improving aeration, drainage, and moisture retention.

3.6 Planting

3.6.7 Planting Guidelines

Application

- Urban Area
 - Streets where the verge width is greater than 1.0 m and less than 1.5 m.

Product/ Material

- All plantings and soils to be in accordance with AS 2303:2015 - Tree Stock for Landscape Use, AS4419-2003- Soils for Landscaping and Garden Use, AS4454-2003 Compost Soil Conditioners and Mulches, and AS4373-2007 Pruning of Amenity Trees.
- Tree plantings and massed groundcover plantings to have
 - Large healthy root systems, with no evidence of root curl, restriction or damage;
 - Vigorous, well established, free from disease and pests, of good form consistent with the species or variety, and
 - Hardened off, not soft or forced, and suitable for planting in the natural climatic conditions prevailing at the site.
- Clear trunk height of 2m.
- All new/replacement trees to be minimum 200L pot size to Natspect.
- Soil mix as approved by Sydney Olympic Park Authority.
- Soil vault cells to be used under adjacent paved areas to increase soil volumes for tree plantings.
- Mulch as specified to a max. 75mm. Mulch must be free of deleterious and extraneous matter, including soil, weeds, rocks, twigs and the like. To be approved by Sydney Olympic Park Authority.
- Spade edge to massed planting.

Supplier

As approved by Sydney Olympic Park Authority

Tree Planting in Planted Verge (less than 1.5m wide)



Sample - Tree planting in verge (1<1x<1.5m wide)

Construction Notes

- Tree planting to be placed in centre of verge
- Service clearances to be maintained.
- Tree planting to be carried out by a Landscape Contractors Association (LCA) affiliated contractor with demonstrated experience in landscape work, tree planting and tree establishment .
- Planting establishment period to commence at date of practical completion.
- Required establishment period of 2 years.
- All soil volumes to be calculated by qualified Arborist/ registered Landscape Architect.
- All delivery, handling and placement of structural soil to be under supervision of qualified Arborist.
- Mulch to be kept 50mm from stems to avoid collar rot.

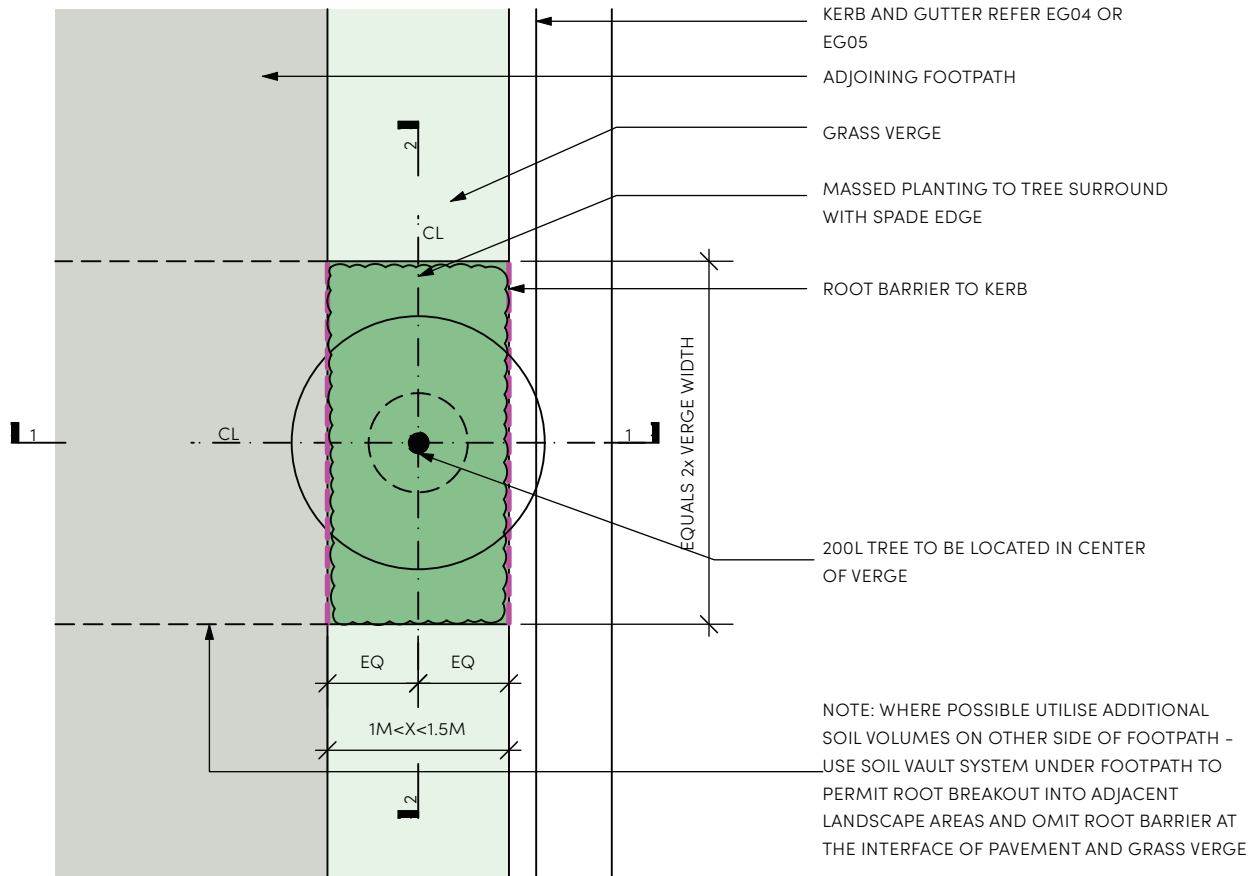

PLAN 1:50

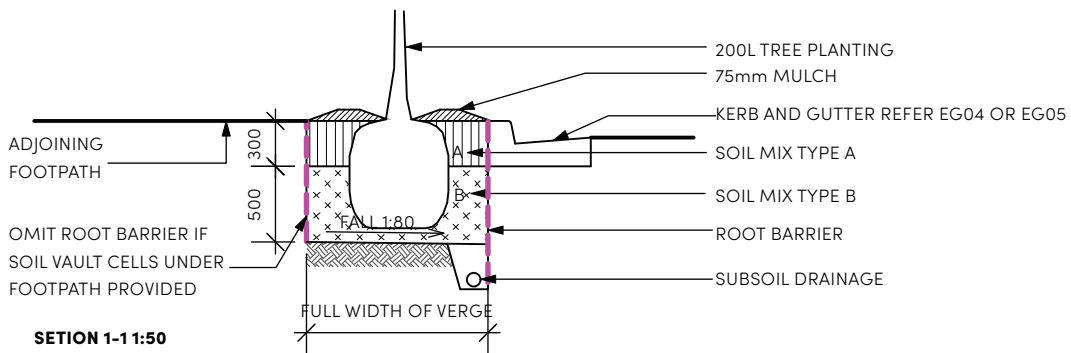

SECTION 1-1 1:50

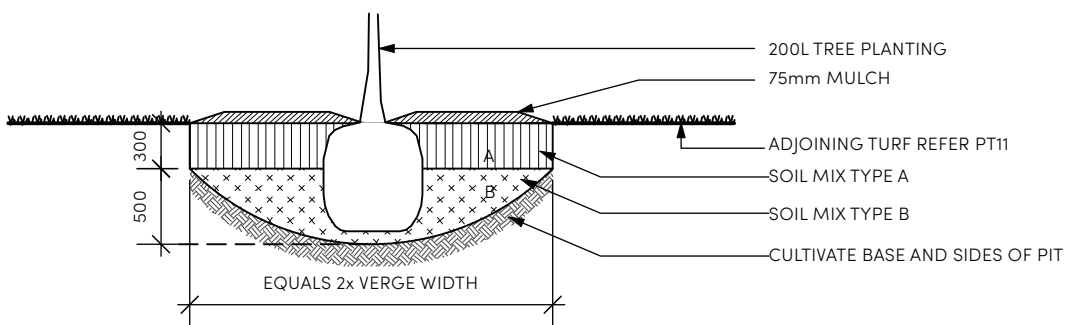

SECTION 2-2 1:50

3.6 Planting

3.6.7 Planting Guidelines

Application

- Urban Area
 - Streets where the verge width is greater than 1.5 m.

Product/ Material

- All plantings and soils to be in accordance with AS 2303:2015 - Tree Stock for Landscape Use, AS4419-2003- Soils for Landscaping and Garden Use, AS4454-2003 Compost Soil Conditioners and Mulches, and AS4373-2007 Pruning of Amenity Trees.
- Tree plantings and massed groundcover plantings to have
 - Large healthy root systems, with no evidence of root curl, restriction or damage;
 - Vigorous, well established, free from disease and pests, of good form consistent with the species or variety, and
 - Hardened off, not soft or forced, and suitable for planting in the natural climatic conditions prevailing at the site.
- Clear trunk height of 2m.
- All new/replacement trees to be minimum 200L pot size to Natspect.
- Soil mix as approved by Sydney Olympic Park Authority.
- Soil vault cells to be used under adjacent paved areas to increase soil volumes for tree plantings.
- Mulch as specified to a max. 75mm. Mulch must be free of deleterious and extraneous matter, including soil, weeds, rocks, twigs and the like. To be approved by Sydney Olympic Park Authority.
- Spade edge to massed planting.

Supplier

As approved by Sydney Olympic Park Authority

Tree Planting in Verge (greater than 1.5m wide)



Sample - Tree planting in verge (greater than 1.5m wide)

Construction Notes

- Tree planting to be placed in centre of verge.
- Service clearances to be maintained.
- Tree planting to be carried out by a Landscape Contractors Association (LCA) affiliated contractor with demonstrated experience in landscape work, tree planting and tree establishment.
- Planting establishment period to commence at date of practical completion.
- Required establishment period of 2 years
- All soil volumes to be calculated by qualified Arborist/ registered Landscape Architect.
- All delivery, handling and placement of structural soil to be under supervision of qualified Arborist.
- Mulch to be kept 50mm from stems to avoid collar rot.

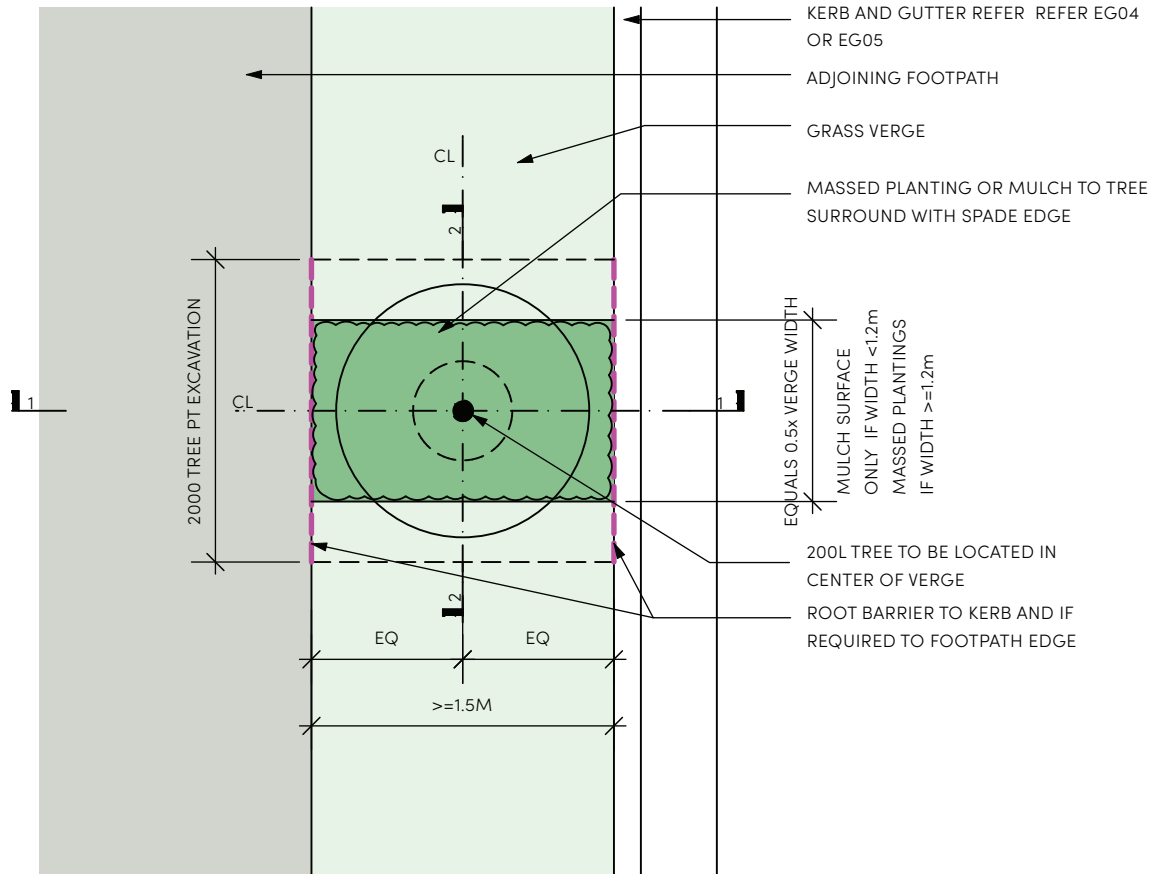

PLAN 1:50

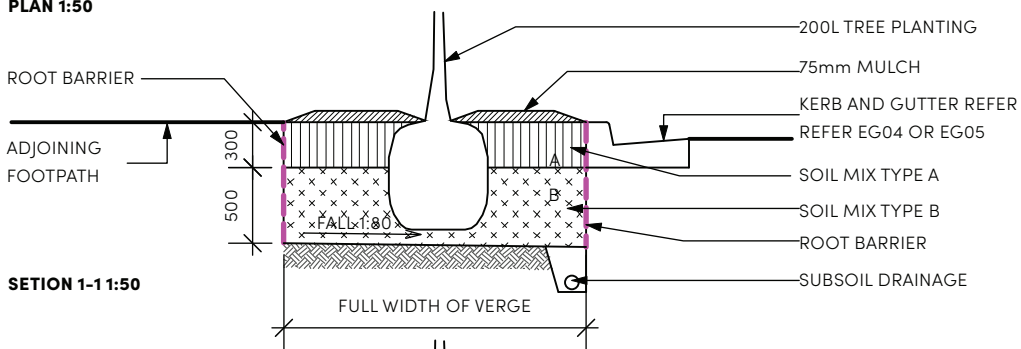

SECTION 1-1:1:50

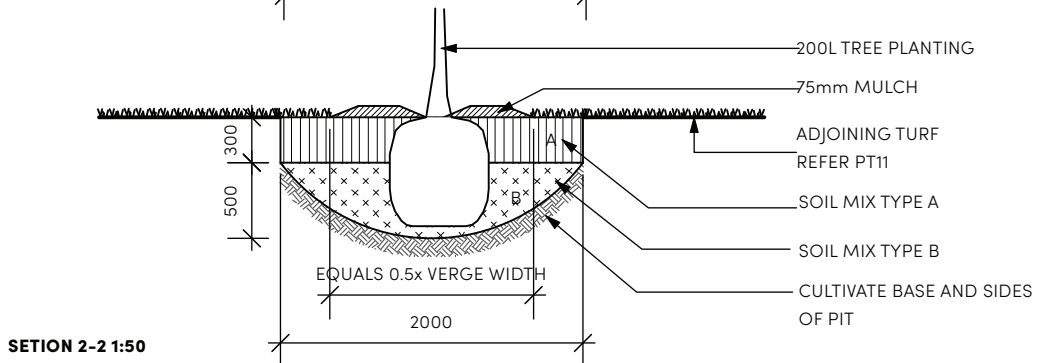

SECTION 2-2:1:50

3.6 Planting

3.6.7 Planting Guidelines

Application

- Urban Area

Product/ Material

- All plantings and soils shall be in accordance with AS 2303:2015 - Tree Stock for Landscape Use, AS4419-2003- Soils for Landscaping and Garden Use, AS4454-2003 Compost Soil Conditioners and Mulches, and AS4373-2007 Pruning of Amenity Trees.
- Tree plantings and massed groundcover plantings to have
 - Large healthy root systems, with no evidence of root curl, restriction or damage;
 - Vigorous, well established, free from disease and pests, of good form consistent with the species or variety, and
 - Hardened off, not soft or forced, and suitable for planting in the natural climatic conditions prevailing at the site.
- Clear trunk height of 2m.
- All new/replacement trees to be minimum 200L pot size to Natspect.
- Soil mix and structural vault system as approved by Sydney Olympic Park Authority.
- Tree grate (refer Section 3.2 F15)
- Permeable pavers (refer Section 3.1 PL08)

Supplier

As approved by Sydney Olympic Park Authority

Tree Planting with Tree Grate in Paved Footpath



Sample - Tree planting with tree grate in paved footpath

Construction Notes

- Service clearances to be maintained.
- Tree planting to be carried out by a Landscape Contractors Association (LCA) affiliated contractor with demonstrated experience in landscape work, tree planting and tree establishment.
- Planting establishment period to commence at date of practical completion.
- Required establishment period of 2 years.
- All delivery, handling and placement of structural soil to be under supervision of qualified Arborist.
- All soil volumes to be calculated by qualified Arborist/ registered Landscape Architect.

Also refer to this manual:

- Section 3.1 PL08 for permeable pavers
- Section 3.2 F15 for tree grate

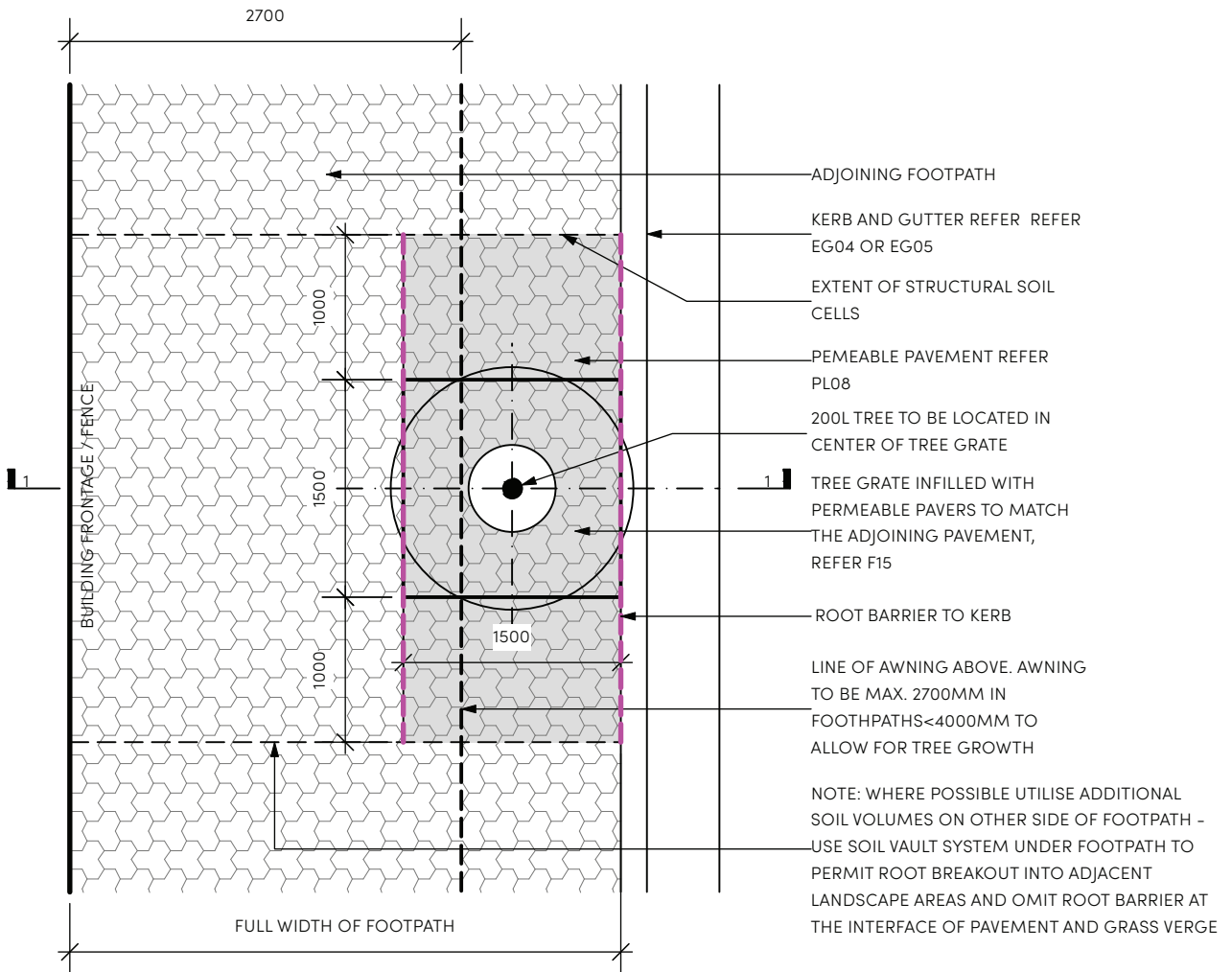

PLAN 1:50

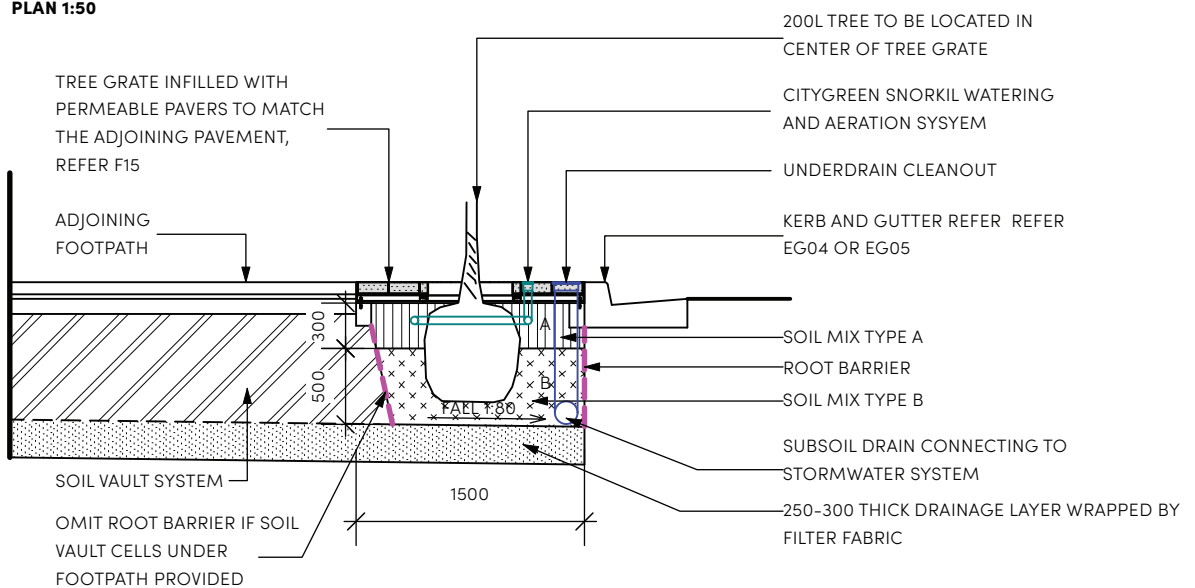

SECTION 1-1 1:50

3.6 Planting

3.6.7 Planting Guidelines

Application

- Urban Area
 - Streets with garden tree pit in the paved footpath

Product/ Material

- All plantings and soils shall be in accordance with AS 2303:2015 - Tree Stock for Landscape Use, AS4419-2003- Soils for Landscaping and Garden Use, AS4454-2003 Compost Soil Conditioners and Mulches, and AS4373-2007 Pruning of Amenity Trees.
- Tree plantings and massed groundcover plantings to have
 - Large healthy root systems, with no evidence of root curl, restriction or damage;
 - Vigorous, well established, free from disease and pests, of good form consistent with the species or variety, and
 - Hardened off, not soft or forced, and suitable for planting in the natural climatic conditions prevailing at the site.
- Clear trunk height of 2m.
- All new/replacement trees to be minimum 200L pot size to Natspect.
- Soil mix as approved by Sydney Olympic Park Authority
- Mulch as specified to a max. 75mm. Mulch must be free of deleterious and extraneous matter, including soil, weeds, rocks , twigs and the like. To be approved by Sydney Olympic Park Authority.

Supplier

As approved by Sydney Olympic Park Authority

Tree Planting with Garden Bed in Paved Footpath



Sample - Tree planting with garden bed in paved footpath

Construction Notes

- Tree planting to be placed in centre of the garden tree pit.
- Service clearances to be maintained.
- Tree planting to be carried out by a Landscape Contractors Association (LCA) affiliated contractor with demonstrated experience in landscape work, tree planting and tree establishment.
- Planting establishment period to commence at date of practical completion.
- Required establishment period of 2 years.
- All soil volumes to be calculated by qualified arborist/ registered Landscape Architect.
- Mulch to be kept 50mm from stems to avoid collar rot.

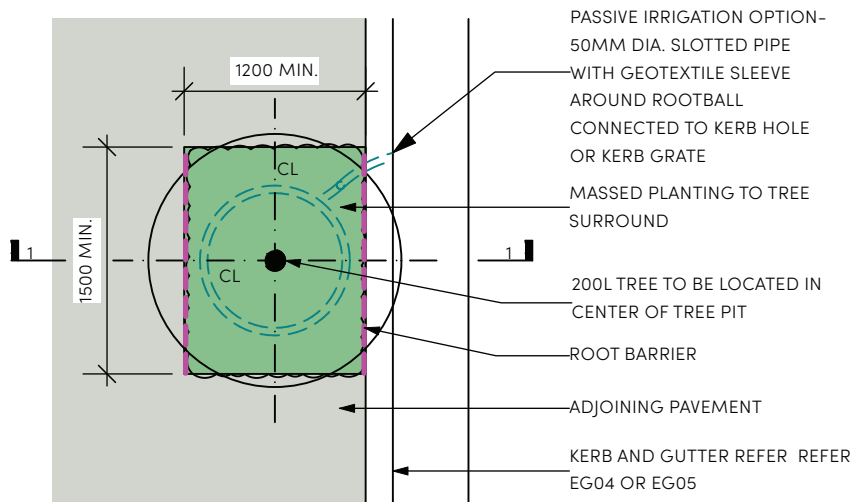

PLAN 1:50

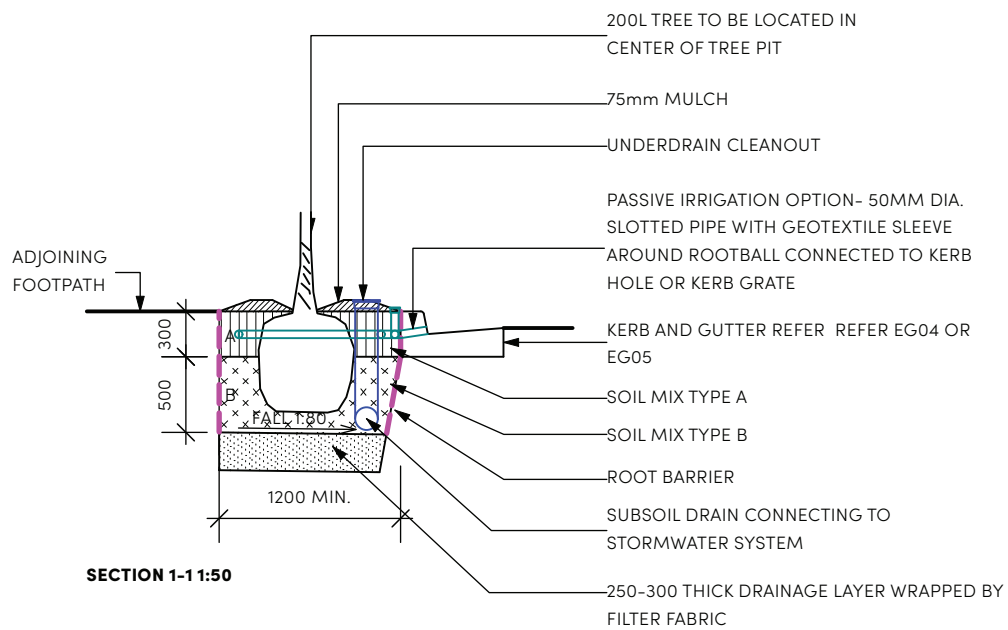

SECTION 1-1 1:50

3.6 Planting

3.6.7 Planting Guidelines

Application

- Urban Area
 - Streets with garden tree pit in the paved footpath
- The use of continuous planting trenches, structural cells, suspended pavements and other tree planting technology will be considered based on specific site conditions. Actual designs shall be developed and submitted to Sydney Olympic Park Authority based on these technical details for consideration prior to any installation.

Product/ Material

- All plantings and soils to be in accordance with AS 2303:2015 - Tree Stock for Landscape Use, AS4419-2003- Soils for Landscaping and Garden Use, AS4454-2003 Compost Soil Conditioners and Mulches, and AS4373-2007 Pruning of Amenity Trees.
- Tree plantings and massed groundcover plantings to have
 - Large healthy root systems, with no evidence of root curl, restriction or damage;
 - Vigorous, well established, free from disease and pests, of good form consistent with the species or variety, and
 - Hardened off, not soft or forced, and suitable for planting in the natural climatic conditions prevailing at the site.
- Clear trunk height of 2m.
- All new/replacement trees to be minimum 200L pot size to Natspect.
- Soil mix as approved by Sydney Olympic Park Authority.
- Mulch as specified to a max. 75mm. Mulch must be free of deleterious and extraneous matter, including soil, weeds, rocks, twigs and the like. To be approved by Sydney Olympic Park Authority.

Supplier

Stratavault

Citygreen or equivalent approved by the Authority

Tree Planting with Soil Vault System in Paved Footpath



Sample - Tree planting with soil vault system

Address: L6 10 Herb Elliott Ave Sydney Olympic Park
NSW 2127

Phone: 1300 066 949

Web: <https://citygreen.com//>

Construction Notes

- Install soil vault system as per manufacturers' recommendations. Geotechnical report may be required to confirm the suitable stratavault module.
- Tree planting to be placed in centre of the garden tree pit.
- Service clearances to be maintained.
- Tree planting to be carried out by a Landscape Contractors Association (LCA) affiliated contractor with demonstrated experience in landscape work, tree planting and tree establishment.
- Planting establishment period to commence at date of practical completion.
- Required establishment period of 2 years.
- All soil volumes to be calculated by qualified Arborist/ registered Landscape Architect.
- Mulch to be kept 50mm from stems to avoid collar rot.

NOTE:
SOIL VAULT SYSTEM TO BE INSTALLED 2 HIGH AND 2 WIDE AS SHOWN. LENGTH AND DEPTH MAY VARY DUE TO SITE CONDITION OR DESIGN REQUIREMENTS.

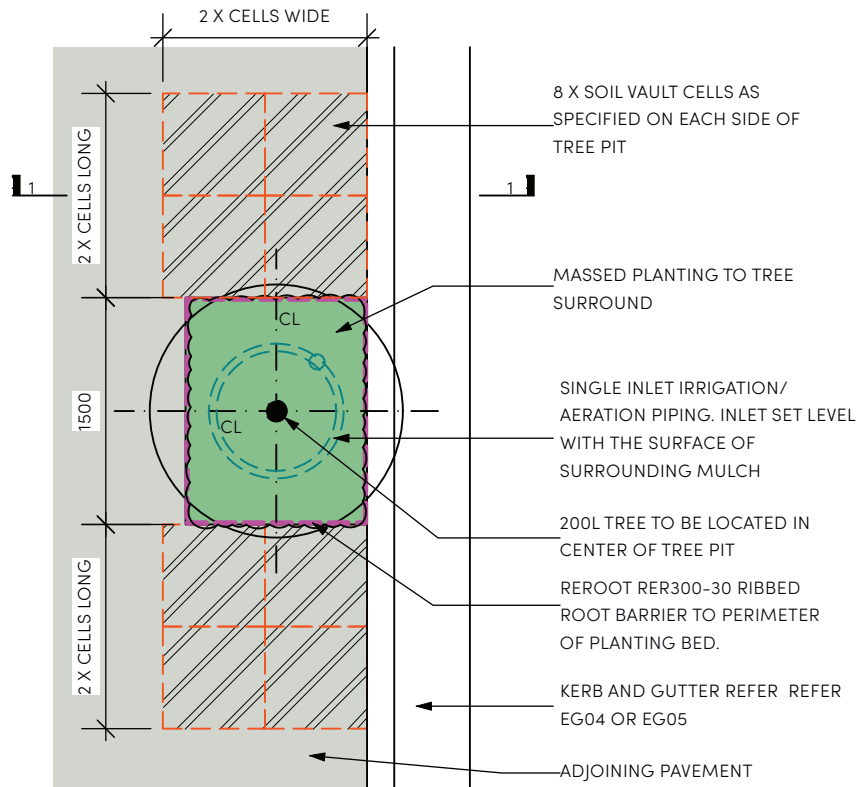

PLAN 1:50

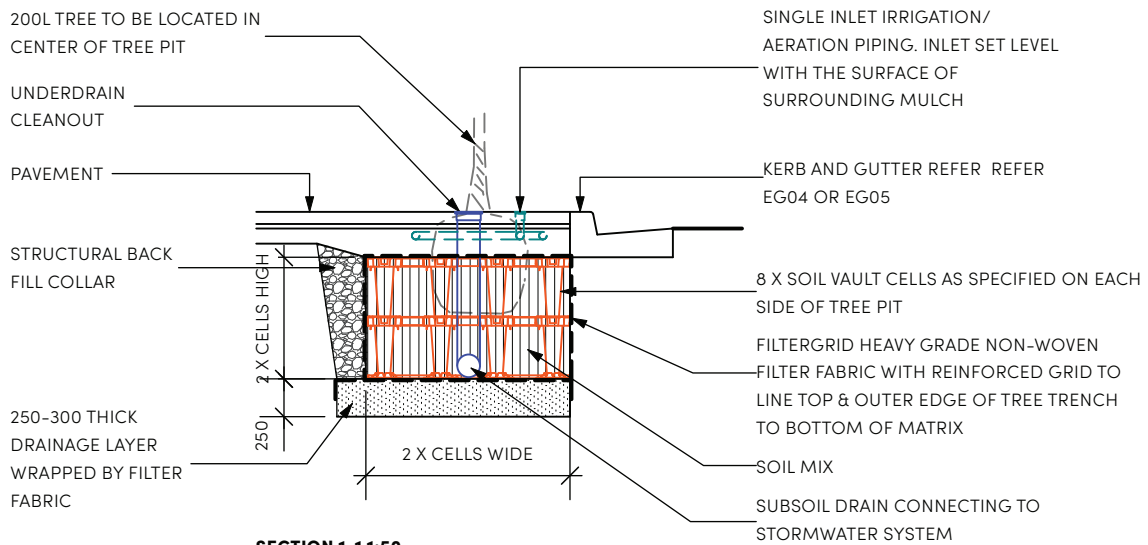

SECTION 1-1:50

3.6 Planting

3.6.7 Planting Guidelines

Application

- Urban Area
 - Kerb island on parking lane
- The use of continuous planting trenches, soil vault system, suspended pavements and other tree planting technology will be considered based on specific site conditions. Actual designs to be developed and submitted to Sydney Olympic Park Authority based on these technical details for consideration prior to any installation.

Product/ Material

- All plantings and soils to be in accordance with AS 2303:2015 - Tree Stock for Landscape Use, AS4419-2003- Soils for Landscaping and Garden Use, AS4454-2003 Compost Soil Conditioners and Mulches, and AS4373-2007 Pruning of Amenity Trees.
- Tree plantings and massed groundcover plantings must
 - Have large healthy root systems, with no evidence of root curl, restriction or damage;
 - Be vigorous, well established, free from disease and pests, of good form consistent with the species or variety, and
 - Be hardened off, not soft or forced, and suitable for planting in the natural climatic conditions prevailing at the site.
- Clear trunk height of 2m.
- All new/replacement trees to be minimum 200L pot size to Natspect.
- Soil mix as approved by Sydney Olympic Park Authority.
- Soil vault system as approved by Sydney Olympic Park Authority.
- Mulch as specified to a max. 75mm. Mulch to be free of deleterious and extraneous matter, including soil, weeds, rocks, twigs and the like. To be approved by Sydney Olympic Park Authority.

Tree Planting in Carriageway - Passive Irrigation



Sample - Tree planting in carriageway

Supplier

As approved by Sydney Olympic Park Authority

Construction Notes

- Tree planting to be placed in centre of kerb island.
- Service clearances to be maintained.
- Tree planting to be carried out by a Landscape Contractors Association (LCA) affiliated contractor with demonstrated experience in landscape work, tree planting and tree establishment.
- Planting establishment period to commence at date of practical completion.
- Required establishment period of 2 years.
- All soil volumes to be calculated by qualified Arborist/ registered Landscape Architect.
- All delivery, handling and placement of structural soil to be under supervision of qualified Arborist.
- Mulch to be kept 50mm from stems to avoid collar rot.

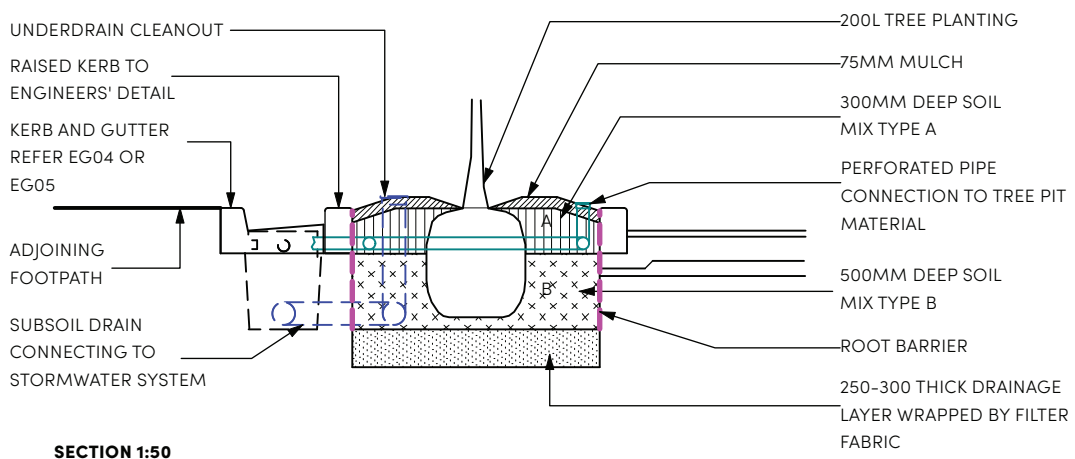
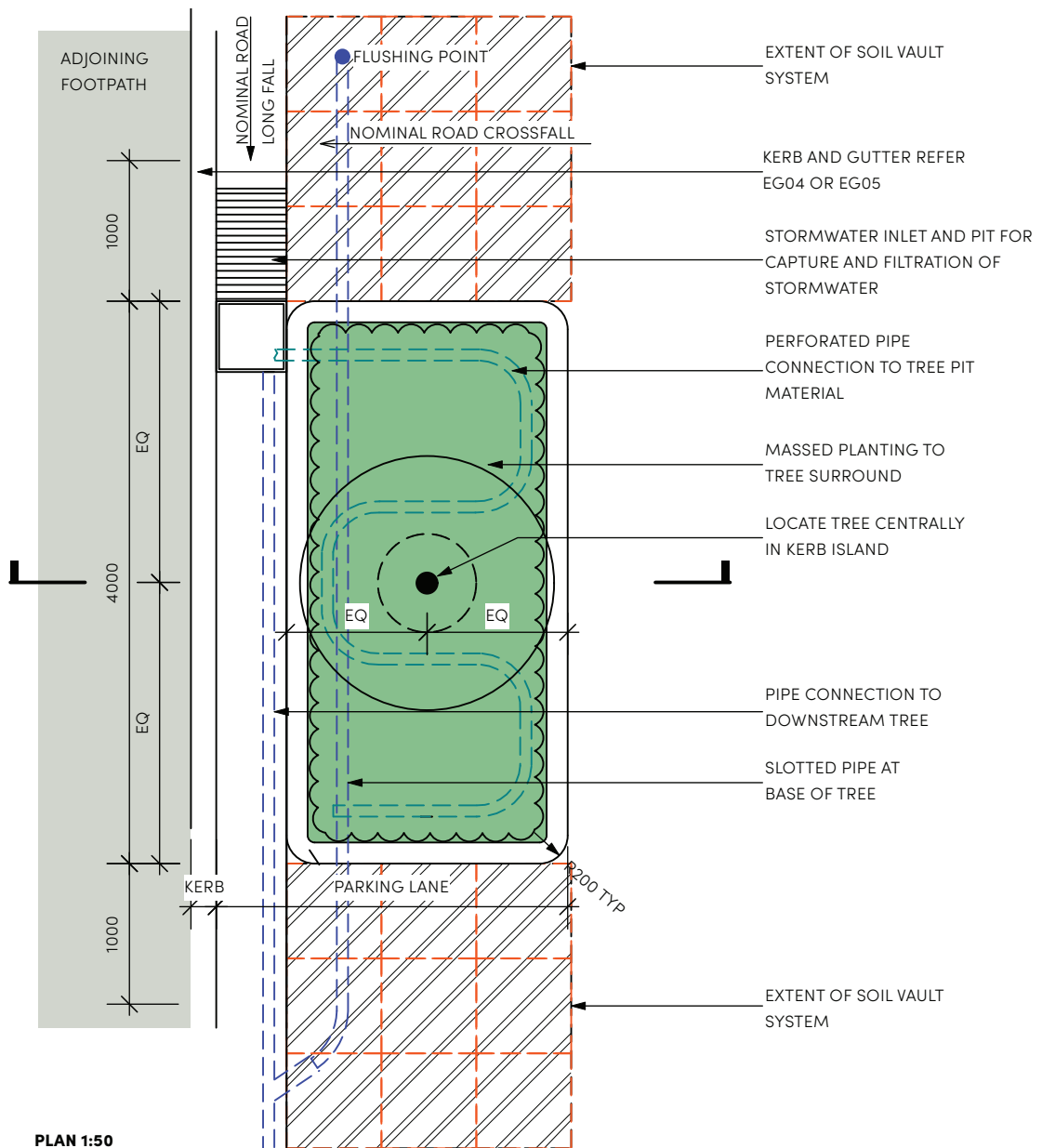

3.6 Planting

3.6.7 Planting Guidelines

Application

- Urban Area
 - Kerb island on parking lane
 - Location identified as a potential WSUD opportunity
- Technical details are to be developed further based on consultation with Sydney Olympic Park Authority and site specific designs to be submitted to Sydney Olympic Park Authority for approval prior to any installation.

Product/ Material

- All plantings and soils to be in accordance with AS 2303:2015 - Tree Stock for Landscape Use, AS4419-2003- Soils for Landscaping and Garden Use, AS4454-2003 Compost Soil Conditioners and Mulches, and AS4373-2007 Pruning of Amenity Trees.
- Tree plantings and massed groundcover plantings must
 - Have large healthy root systems, with no evidence of root curl, restriction or damage;
 - Be vigorous, well established, free from disease and pests, of good form consistent with the species or variety, and
 - Be hardened off, not soft or forced, and suitable for planting in the natural climatic conditions prevailing at the site.
- Plant selection should be appropriate for rain garden conditions.
- Clear trunk height of 2m.
- All new/replacement trees to be minimum 200L pot size to Natspect.
- All required materials such as liners, soil vault system, filter media, transition media, drainage later etc. should be specified and as approved by Sydney Olympic Park Authority.
- Mulch as specified to a max. 75mm. Mulch to be "no float" mulch and be free of deleterious and extraneous matter, including soil, weeds, rocks, twigs and the like. To be approved by Sydney Olympic Park Authority.

Tree Planting in Carriageway - Bioretention Tree Pit



Sample - Tree planting in carriageway - bioretention tree pit

Supplier

As approved by Sydney Olympic Park Authority

Construction Notes

- Tree planting to be placed in centre of kerb island.
- Service clearances to be maintained.
- Tree planting to be carried out by a Landscape Contractors Association (LCA) affiliated contractor with demonstrated experience in landscape work, tree planting and tree establishment.
- Planting establishment period to commence at date of practical completion.
- Required establishment period of 2 years.
- All soil volumes to be calculated by qualified Arborist/ registered Landscape Architect.
- All delivery, handling and placement of structural soil to be under supervision of qualified Arborist.
- Any landscaping elements which are intended as WSUD devices must:
 - Have a high-flow bypass
 - Be designed to have a maximum flow velocity in the landscape features not exceeding 0.3m/ sec
 - Include an upstream GPT to prevent visible pollution in the landscaping areas.

3.6 Planting

3.6.7 Planting Guidelines

Application

- Urban Area
 - Parks
- Parklands

Product/ Material

- All plantings and soils to be in accordance with AS 2303:2015 - Tree Stock for Landscape Use, AS4419-2003- Soils for Landscaping and Garden Use, AS4454-2003 Compost Soil Conditioners and Mulches, and AS4373-2007 Pruning of Amenity Trees.
- Tree plantings to have
 - Large healthy root systems, with no evidence of root curl, restriction or damage;
 - Vigorous, well established, free from disease and pests, of good form consistent with the species or variety, and
 - Hardened off, not soft or forced, and suitable for planting in the natural climatic conditions prevailing at the site.
- Clear trunk height of 2m.
- All new/replacement trees to be minimum 200L pot size to Natspect.
- Soil mix as approved by Sydney Olympic Park Authority.
- Mulch as specified to a max. 75mm. Mulch must be free of deleterious and extraneous matter, including soil, weeds, rocks , twigs and the like. To be approved by Sydney Olympic Park Authority.
- Spade edge to edge of mulch zone.

Supplier

As approved by Sydney Olympic Park Authority

Tree Planting in Park



Sample - Tree planting in park

Construction Notes

- Tree planting to be placed in centre of kerb island.
- Service clearances to be maintained.
- Tree planting to be carried out by a Landscape Contractors Association (LCA) affiliated contractor with demonstrated experience in landscape work, tree planting and tree establishment.
- Planting establishment period to commence at date of practical completion.
- Required establishment period of 2 years.
- All soil volumes to be calculated by qualified arborist/ registered Landscape Architect.
- All delivery, handling and placement of structural soil to be under supervision of qualified Arborist.
- Mulch shall be kept 50mm from stems to avoid collar rot.

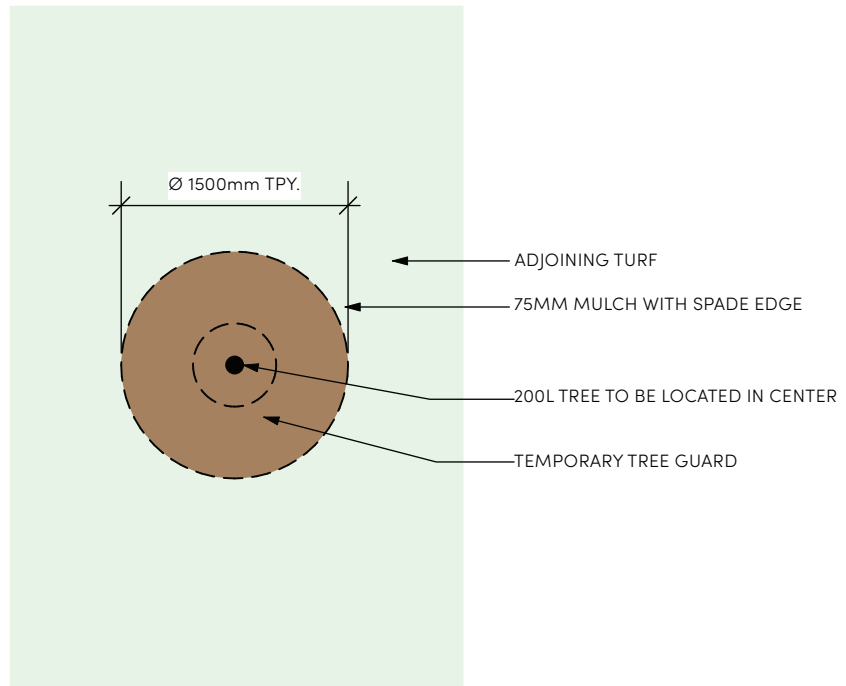

PLAN 1:50

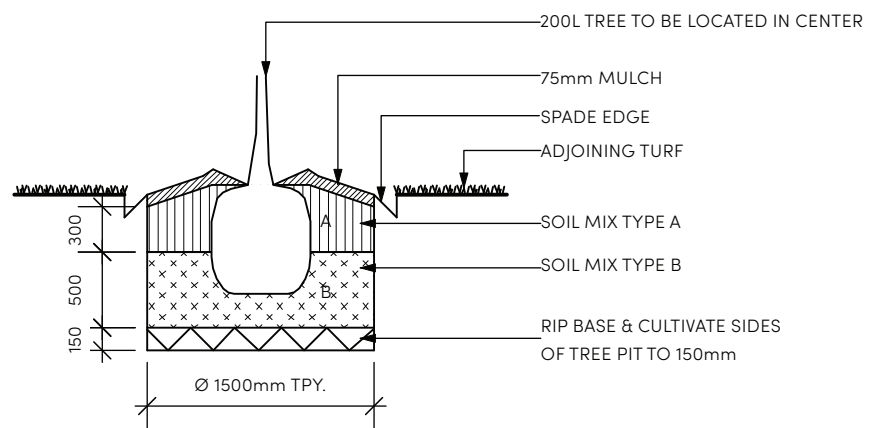

SECTION 1:50

3.6 Planting

3.6.7 Planting Guidelines

Application

- Urban Area
 - Garden bed or mass planting bed in streets and parks
- Parklands
 - Garden bed or mass planting bed in streets and parklands

Product/ Material

- All planting and soils to be in accordance with AS4419-2003- Soils for Landscaping and Garden Use, and AS4454-2003 Compost Soil Conditioners and Mulches.
- Plantings to have
 - Large healthy root systems, with no evidence of root curl, restriction or damage;
 - Vigorous, well established, free from disease and pests, of good form consistent with the species or variety, and
 - Hardened off, not soft or forced, and suitable for planting in the natural climatic conditions prevailing at the site.
- Plantings to be minimum 150mm pot size.
- Soil mix as approved by Sydney Olympic Park Authority.
- Fertiliser and backfill as specified and approved by Sydney Olympic Park Authority.
- Mulch as specified to a max. 75mm. Mulch must be free of deleterious and extraneous matter, including soil, weeds, rocks, twigs and the like. To be approved by Sydney Olympic Park Authority.

Supplier

As approved by Sydney Olympic Park Authority

Construction Notes

- For garden bed, subsoil to be ripped and cultivated to a minimum depth of 150mm with 300mm garden soil mix to be spread over the prepared subsoil base.

Garden Bed and Mass Planting Bed



Sample - Garden bed / mass planting bed

- For mass planting bed, subsoil to be ripped and cultivated to a minimum depth of 100mm with 150mm garden soil mix to be spread over the prepared subsoil base.
- Top soil to be spread on the prepared subsoil and grade evenly, compacted lightly and uniformly in 150mm layers. Avoid differential subsidence and excess compaction.
- Produce a finished topsoil surface to the following requirements:
 - Finish to design levels, allowing for mulch, which is to finish flush with adjoining surface.
 - Smooth and free from stones or lumps of soil.
 - Graded to drain freely, without ponding, to catchment points.
 - Graded evenly and ready for planting.
- Planting establishment period to commence at date of practical completion.
- Required establishment period of 2 years.

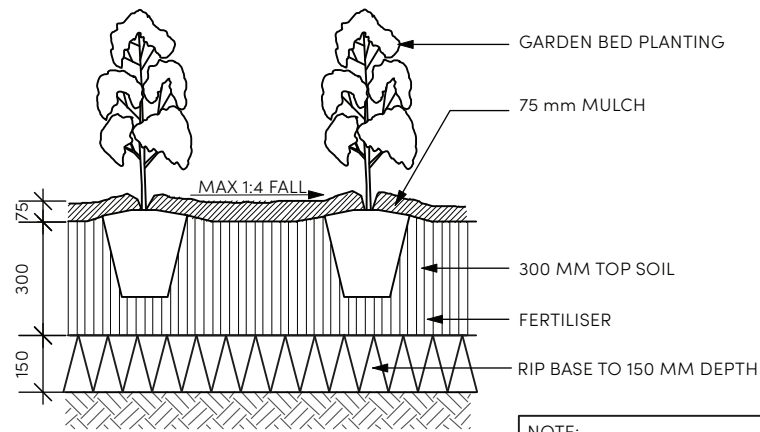

SECTION - GARDEN BED 1:20

NOTE:
 FALL BASE OF PLANTING BED
 PREPARATION TO
 DRAINAGE OUTLETS/
 SUBSOIL DRAINAGE WHERE
 PROVIDED

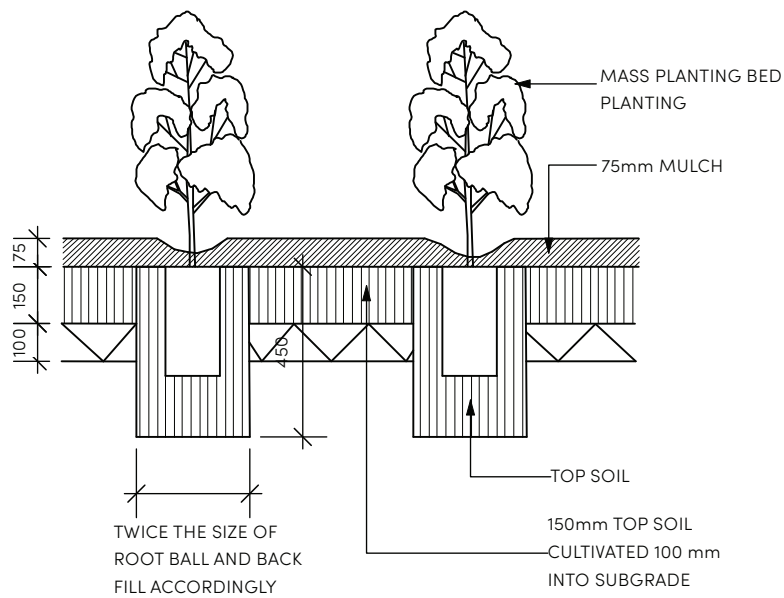

SECTION - MASS PLANTING BED 1:20

3.6 Planting

3.6.7 Planting Guidelines

Application

- Parklands

Product/ Material

- All plantings and soils to be in accordance with AS4419-2003- Soils for Landscaping and Garden Use, and AS4454-2003 Compost Soil Conditioners and Mulches.
- Plantings to have
 - Large healthy root systems, with no evidence of root curl, restriction or damage;
 - Vigorous, well established, free from disease and pests, of good form consistent with the species or variety, and
 - Hardened off, not soft or forced, and suitable for planting in the natural climatic conditions.
- Soil mix as approved by Sydney Olympic Park Authority.
- Mulch as specified to a max. 75mm. Mulch must be free of deleterious and extraneous matter, including soil, weeds, rocks , twigs and the like. To be approved by Sydney Olympic Park Authority.

Supplier

As approved by Sydney Olympic Park Authority

Construction Notes

- Existing ground to be ripped and cultivated to a minimum depth of 150mm.
- Backfill planting hole with top soil, graded evenly to adjoining surface finish.
- Planting establishment period to commence at date of practical completion.
- Required establishment period as advised by Sydney Olympic Park Authority.

Revegetation



Sample - Revegetation

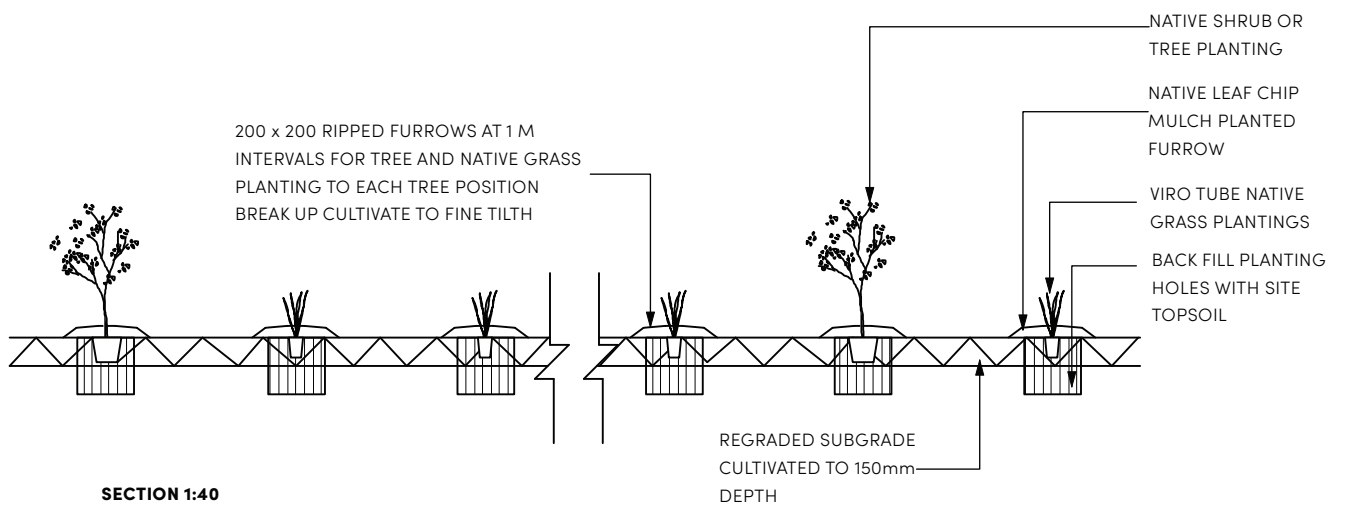

3.6 Planting

3.6.7 Planting Guidelines

Application

- Urban Area
- Parklands

Product/ Material

- All plantings and soils to be in accordance with AS4419-2003- Soils for Landscaping and Garden Use, and AS4454-2003 Compost Soil Conditioners and Mulches.
- Contractor to obtain turf rolls from a specialist grower of cultivated turf.
- Provide turf of even thickness (25-40mm), free from weeds and other foreign matter.
- Supply turf is to demonstrate vigorous growth, be free from obvious signs of stress, weed, pest or disease infestation, damage or physical defects.

Supplier

As approved by Sydney Olympic Park Authority.

Construction Notes

- Deliver the turf within 24 hours of cutting, and lay it within 36 hours of cutting. Prevent it from drying out between cutting and laying.
- Mix the fertiliser thoroughly into the turf underlay before placing the turf. Apply lawn fertiliser at the completion of the first and last mowings to Practical Completion, and at other times as required to maintain healthy grass cover prior to Practical Completion.
- Deliver turf and cultivate site topsoil as detailed. Provide sample area of cultivated topsoil for Sydney Olympic Park Authority approval.
- Profile topsoil and roll to achieve a well compacted and firm base. Prior to laying, water in well to ensure no subsidence. Lightly rake the rolled turf underlay or site topsoil prior to laying turf rolls. Subsidence greater than 15-20mm occurring after the turf is laid will not be accepted and will require turf to be lifted, the topsoil re-profiled and prepared, and new turf laid.

Turf



Sample - Turf

- Lay the turf in the following manner:
 - In stretcher pattern with the joints staggered and close butted.
 - Parallel with the long sides of level areas and with contours on slopes.
 - To finish flush, after tamping, with adjacent finished surfaces of ground, paving edging, or grass seeded areas.
 - Strip turf laying: Close butt the end joints and space the strips butting each other. Finish with an even surface.
- Lightly tamp to an even surface immediately after laying. Do not use a roller.
- Water immediately after laying until the topsoil is moistened to its full depth. Continue watering to maintain moisture to this depth. Keep the grass in a healthy condition.
- Allow for topdressing of the turf following installation, to establish surface smoothness and turf density following establishment.

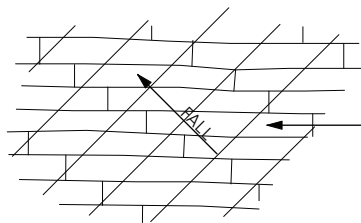

TURF STRIPS TO BE STAGGERED PATTERN & BUTTED AGAINST EACH OTHER LAID AT ANGLE (AS SHOWN) TO CONTOURS

PLAN N.T.S

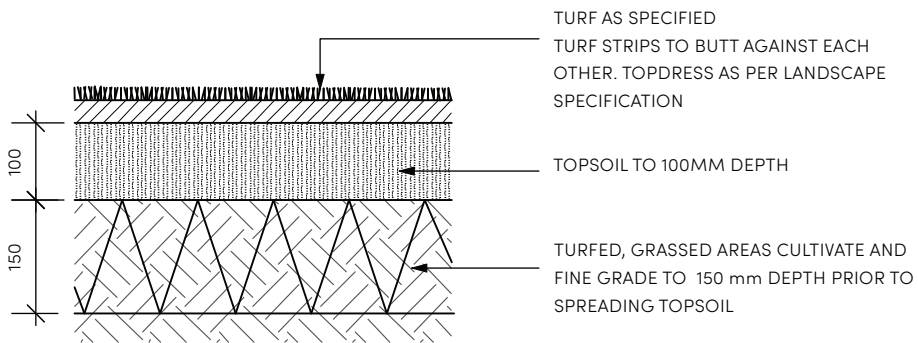

TURF AS SPECIFIED
TURF STRIPS TO BUTT AGAINST EACH OTHER. TOPDRESS AS PER LANDSCAPE SPECIFICATION

TOPSOIL TO 100MM DEPTH

TURFED, GRASSED AREAS CULTIVATE AND FINE GRADE TO 150 mm DEPTH PRIOR TO SPREADING TOPSOIL

SECTION 1:10

3.6 Planting

3.6.7 Planting Guidelines

Application

- Urban Area
 - Street verges
 - Parks
- Parklands
 - Street verges
 - Parklands

Product/ Material

- All plantings and soils to be in accordance with AS4419-2003- Soils for Landscaping and Garden Use, and AS4454-2003 Compost Soil Conditioners and Mulches.
- Plantings to have
 - Large healthy root systems, with no evidence of root curl, restriction or damage;
 - Vigorous, well established, free from disease and pests, of good form consistent with the species or variety, and
 - Hardened off, not soft or forced, and suitable for planting in the natural climatic conditions prevailing at the site.
- Plant selection must be appropriate for swale conditions.
- Sandstone topsoil mix as approved by Sydney Olympic Park Authority.
- Mulch as specified to a max. 75mm. Mulch must be no float mulch and be free of deleterious and extraneous matter, including soil, weeds, rocks, twigs and the like. To be approved by Sydney Olympic Park Authority.

Supplier

As approved by Sydney Olympic Park Authority

Construction Notes

- To engineers' final specification.
- Finish level to be flush with the adjoining surface, with timber edge at interface.
- For planted swale, sides of swale to be no steeper than 1:3, with 16 plants per square meter.

Swale



Sample - Swale

- For turfed swale, sides of swale to be no steeper than 1:4.
- Planting establishment period to commence at date of practical completion.
- Required establishment period of 2 years.

Also refer to Sydney Olympic Park Authority's IECM:

- SW008

